

Imperial [IP] Dimensions
Metric (SI) in Parentheses

CARNES COMPANY 448 S. Main St., P. O. Box 930040, Verona, WI 53593-0040 Phone: (608)845-6411 Fax: (608)845-6504 www.carnes.com

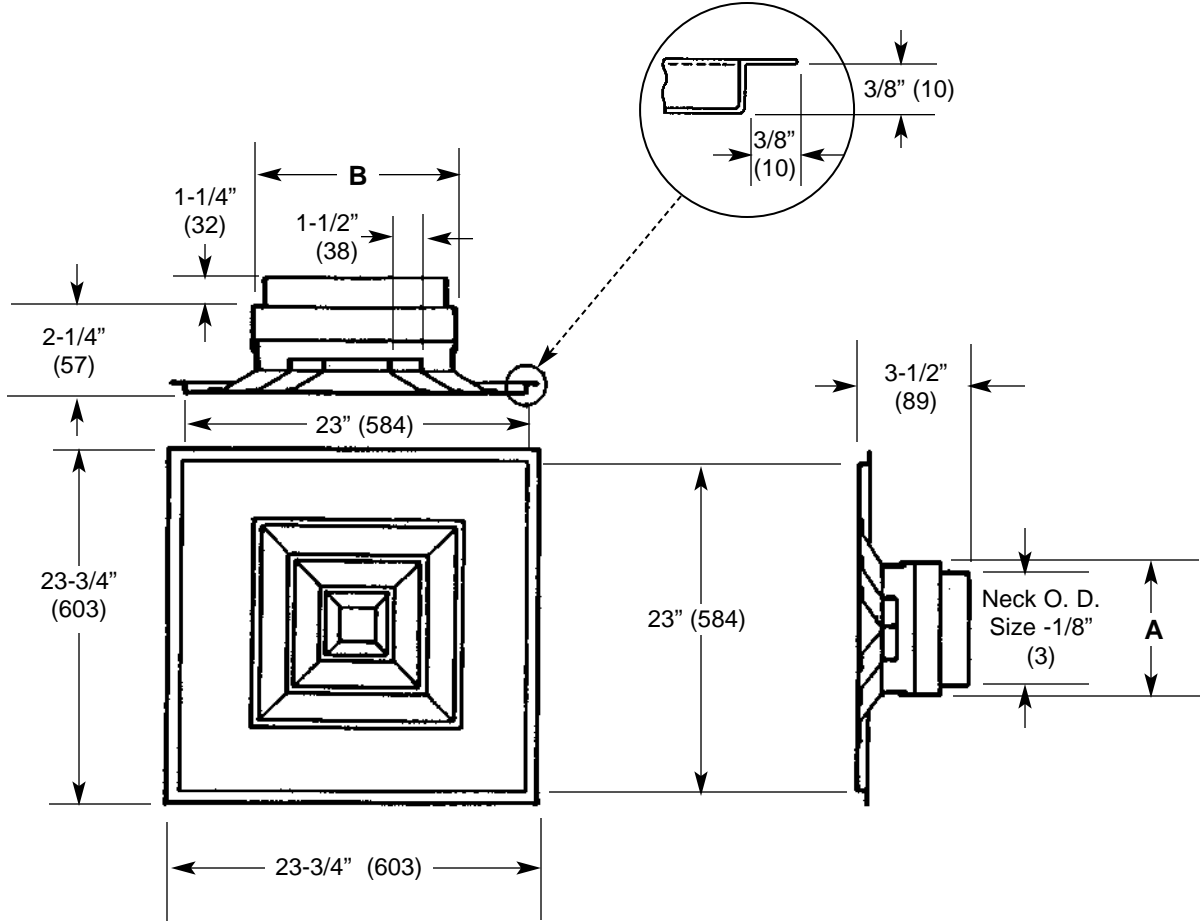

SQUARE

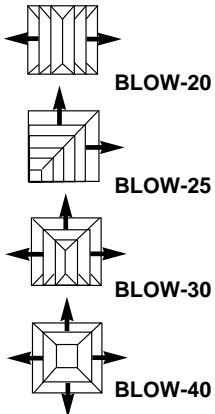

ADJUSTMENT

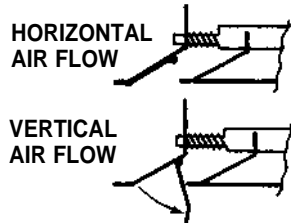

Two spring loaded pins, four pin suspension to ceiling plate. Removable and interchangeable center core assembly.

Note:

1. Standard Finish #11 White Electrocoat

DIMENSIONS LISTED IN INCHES (Millimeters)

Neck Dia.	Size A x B
5 (127)	6 x 6 (152 x 152)
6 (152)	6 x 6 (152 x 152)
6 (152)	9 x 9 (229 x 229)
8 (203)	9 x 9 (229 x 229)
9 (229)	9 x 9 (229 x 229)
10 (254)	12 x 12 (305 x 305)
12 (305)	12 x 12 (305 x 305)
14 (356)	15 x 15 (381 x 381)
15 (381)	15 x 15 (381 x 381)
16 (406)	18 x 18 (457 x 457)
18 (457)	18 x 18 (457 x 457)