

Steel Modular Core Diffuser with Round Inlet Stub Duct Frame

Imperial [IP] Dimensions
Metric (SI) in Parentheses

CARNES COMPANY 448 S. Main St., P. O. Box 930040, Verona, WI 53593-0040 Phone: (608)845-6411 Fax: (608)845-6504 www.carnes.com

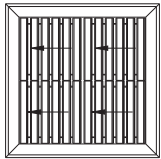

1-Way

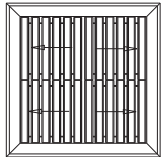

2-Way Opposite

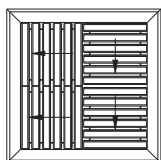

2-Way Corner



3-Way

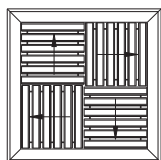

4-Way

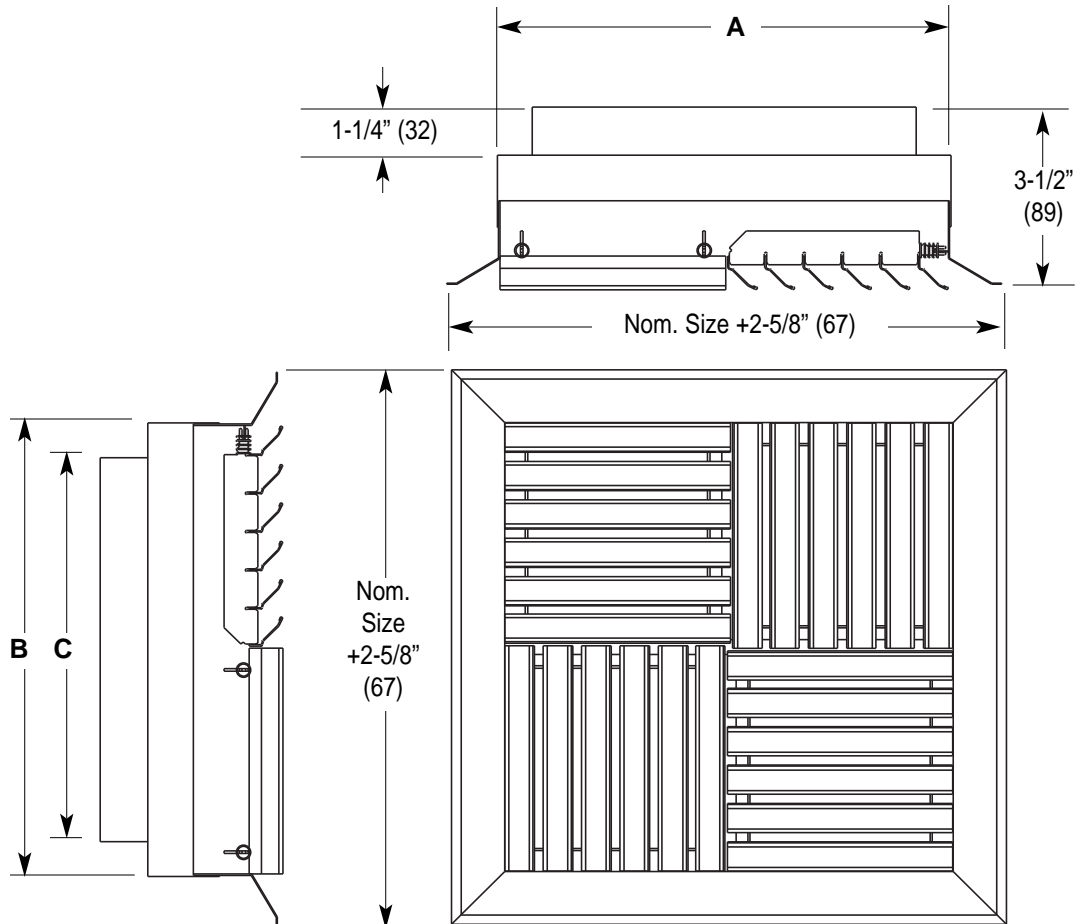

Notes:

1. Construction is steel.
2. Standard finish is electrocoat acrylic baked enamel. Other finishes are available on request.
3. Standard color is #11 Bright White. Other colors are available on request.
4. Metric dimensions are in millimeters.

Nominal Square	Available Nominal Round
Neck Size (A x B)	Inlet Sizes (C)
6" x 6" (152 x 152)	5" (127), 6" (152)
8" x 8" (203 x 203)	6" (152), 8" (203)
10" x 10" (254 x 254)	8" (203), 10" (254)
12" x 12" (305 x 305)	10" (254), 12" (305)
14" x 14" (356 x 356)	12" (305), 14" (356)
16" x 16" (406 x 406)	14" (356), 16" (406)
18" x 18" (457 x 457)	16" (406), 18" (457)
20" x 20" (508 x 508)	18" (457), 20" (508)
22" x 22" (559 x 559)	20" (508), 22" (559)
24" x 24" (610 x 610)	22" (559), 24" (610)

Nominal Round	Actual Round
Neck Size	Neck O. D.
5" (127)	4-7/8" (124)
6" (152)	5-7/8" (149)
8" (203)	7-7/8" (200)
10" (254)	9-7/8" (251)
12" (305)	11-7/8" (302)
14" (356)	13-7/8" (352)
16" (406)	15-7/8" (403)
18" (457)	17-7/8" (454)
20" (508)	19-7/8" (505)
22" (559)	21-7/8" (556)
24" (610)	23-7/8" (606)