

Imperial [IP] Dimensions  
Metric (SI) in Parentheses

CARNES COMPANY 448 S. Main St., P. O. Box 930040, Verona, WI 53593-0040 Phone: (608)845-6411 Fax: (608)845-6504 www.carnes.com

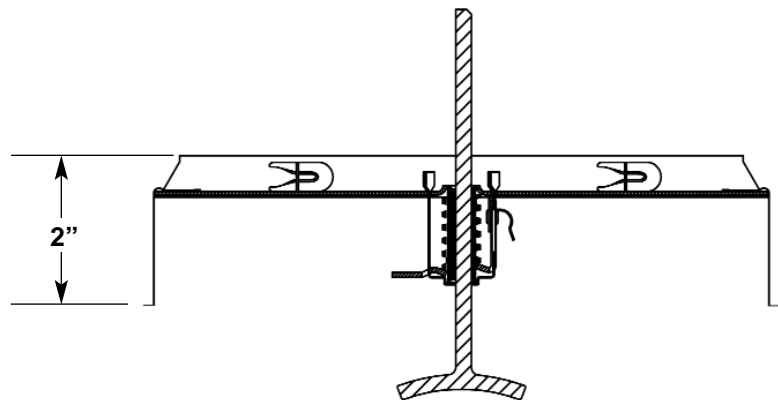
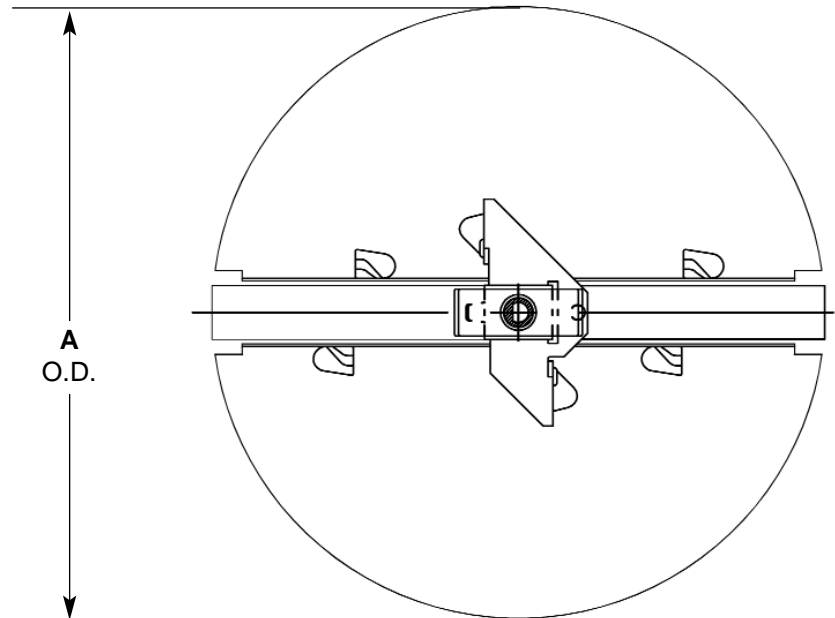
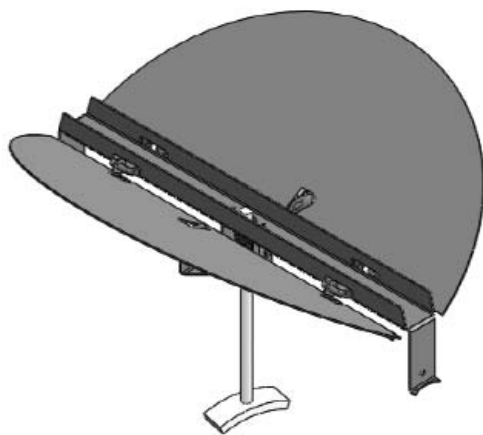

DIMENSIONS LISTED IN INCHES (In Millimeters)	
Model - Size	A - O.D.
KXMC-06 (152)	5-5/8 (143)
KXMC-08 (203)	7-5/8 (194)
KXMC-10 (254)	9-5/8 (244)
KXMC-12 (305)	11-5/8 (295)
KXMC-14 (356)	13-5/8 (346)

Notes:

- 22 ga. steel construction
- Mounts directly into diffuser inlet.
- Removal adjustment handle. Adjustable from face of diffuser.
- Available in sizes 6, 8, 10, 12, 14.
- Brown powder coat finish.