

CARNES COMPANY 448 S. Main St., P. O. Box 930040, Verona, WI 53593-0040 Phone: (608)845-6411 Fax: (608)845-6504 www.carnes.com

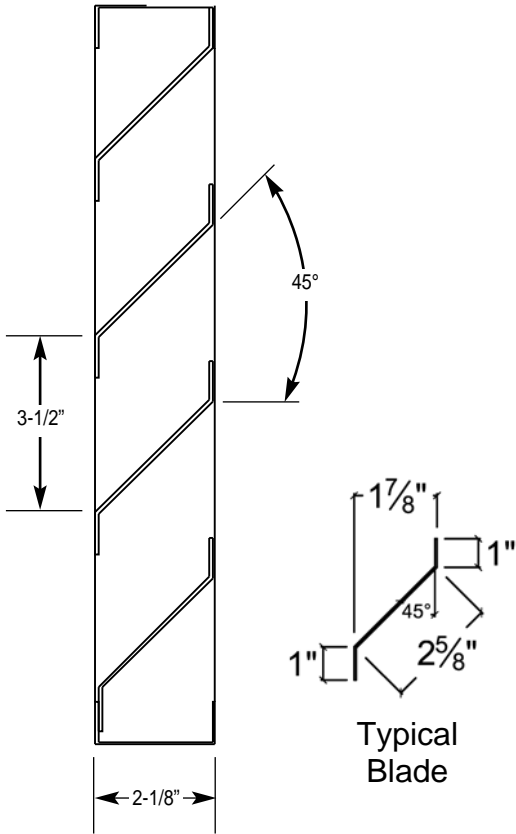

Section View

Typical Blade

Model FFWC Standard Specifications

Frame: 18 gauge galvanized steel, 2" deep

Blades: 20 gauge galvanized steel, positioned at 45° angles on approximately 3.5" centers

Finish: mill galvanized

Screen: 1/2" x .050 expanded flattened aluminum in removable frame. Screen is mounted on inside (rear) as looking from exterior of building.

Maximum Panel Size: 96"w x 72"h

Minimum Panel Size: 8" x 10"

Larger sizes made in multiple sections

Options (at additional cost)

- Filter Racks
- Security Bars
- Variety of Screens
- Sub-Frames
- Selection of finishes; prime coat, kynar, baked enamel, epoxy and heresite

Consult Carnes for other special requirements.

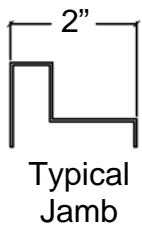

Typical Jamb

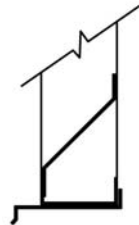

Extended Sill Optional

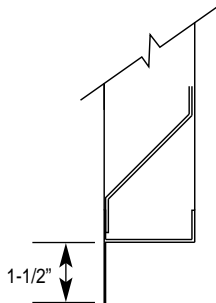

Flanged Frame Optional

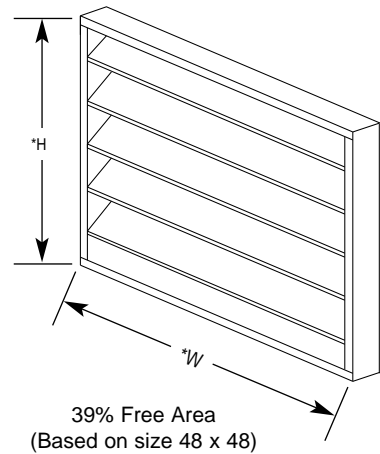

*Width and height dimensions are approximately 1/4" under listed size.

Tag	Qty.	Size		Frame	Variations
		Width	Height		

Project
Arch./Engr.
Representative

Location
Contractor
Date