

CARNES COMPANY, 448 S. Main St., P. O. Box 930040, Verona, WI 53593-0040 Phone: (608)845-6411 Fax: (608)845-6504 carnes@carnes.com

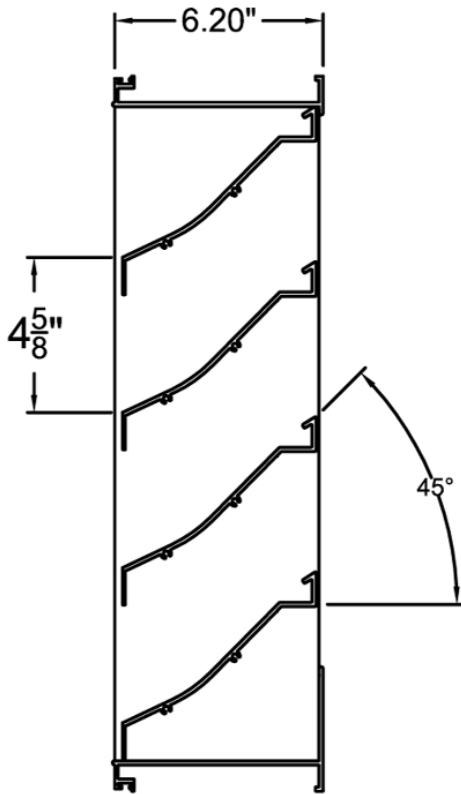

Model FLGC

Standard Specifications

Frame: .125 extruded aluminum, 6.20" deep

Blades: .110 extruded aluminum positioned on a 45° angle on approximately 4.625" centers

Finish: mill aluminum (standard)

Screen: 3/4" x .051" flattened aluminum in removable frame. Screen is mounted as standard on inside (rear) as looking from exterior of building.

Maximum Panel Size: 120"w x 84"h or 84"w x 120"h

Minimum Panel Size: 12"w x 12"h

Options (at additional cost)

- Filter Racks
- Security Bars
- Special Shapes
- Variety of Screens
- Sub-Frames
- Selection of finishes; prime coat, kynar, baked enamel, clear and color anodize, epoxy and heresite

Consult Carnes for other special requirements.

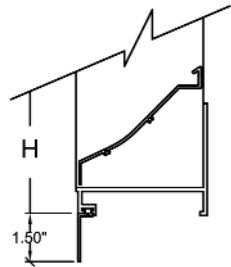

Flanged Frame
Optional

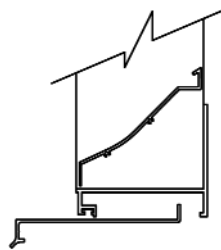

Extended Sill
Optional

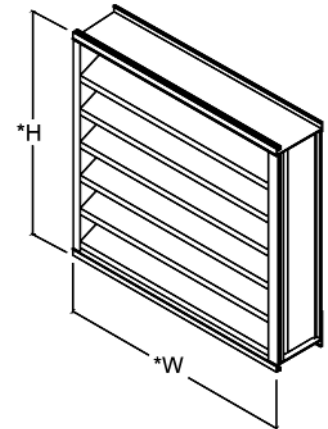

*Width and height dimensions are approximately 1/4" under listed size.

| Tag | Qty. | Size | | Frame | Variations |
|-----|------|-------|--------|-------|------------|
| | | Width | Height | | |
| | | | | | |
| | | | | | |
| | | | | | |
| | | | | | |

Project
Arch./Engr.
Representative

Location
Contractor
Date

Free Area in Square Feet

| HEIGHT INCHES | WIDTH IN INCHES | | | | | | | | | | | | | | | | | | |
|------------------|-----------------|------|-------|-------|-------|-------|-------|-------|-------|-------|-------|-------|-------|-------|-------|-------|-------|-------|-------|
| | 12 | 18 | 24 | 30 | 36 | 42 | 48 | 54 | 60 | 66 | 72 | 78 | 84 | 90 | 96 | 102 | 108 | 114 | 120 |
| 12 | 0.52 | 0.77 | 1.03 | 1.29 | 1.55 | 1.81 | 2.07 | 2.32 | 2.58 | 2.84 | 3.10 | 3.36 | 3.61 | 3.87 | 4.13 | 4.39 | 4.65 | 4.90 | 5.16 |
| 18 | 0.77 | 1.16 | 1.55 | 1.94 | 2.32 | 2.71 | 3.10 | 3.48 | 3.87 | 4.26 | 4.65 | 5.03 | 5.42 | 5.81 | 6.20 | 6.58 | 6.97 | 7.36 | 7.74 |
| 24 | 1.03 | 1.55 | 2.07 | 2.58 | 3.10 | 3.61 | 4.13 | 4.65 | 5.16 | 5.68 | 6.20 | 6.71 | 7.23 | 7.74 | 8.26 | 8.78 | 9.29 | 9.81 | 10.33 |
| 30 | 1.29 | 1.94 | 2.58 | 3.23 | 3.87 | 4.52 | 5.16 | 5.81 | 6.45 | 7.10 | 7.74 | 8.39 | 9.03 | 9.68 | 10.33 | 10.97 | 11.62 | 12.26 | 12.91 |
| 36 | 1.55 | 2.32 | 3.10 | 3.87 | 4.65 | 5.42 | 6.20 | 6.97 | 7.74 | 8.52 | 9.29 | 10.07 | 10.84 | 11.62 | 12.39 | 13.16 | 13.94 | 14.71 | 15.49 |
| 42 | 1.81 | 2.71 | 3.61 | 4.52 | 5.42 | 6.32 | 7.23 | 8.13 | 9.03 | 9.94 | 10.84 | 11.74 | 12.65 | 13.55 | 14.46 | 15.36 | 16.26 | 17.17 | 18.07 |
| 48 | 2.07 | 3.10 | 4.13 | 5.16 | 6.20 | 7.23 | 8.26 | 9.29 | 10.33 | 11.36 | 12.39 | 13.42 | 14.46 | 15.49 | 16.52 | 17.55 | 18.59 | 19.62 | 20.65 |
| 54 | 2.32 | 3.48 | 4.65 | 5.81 | 6.97 | 8.13 | 9.29 | 10.45 | 11.62 | 12.78 | 13.94 | 15.10 | 16.26 | 17.42 | 18.59 | 19.75 | 20.91 | 22.07 | 23.23 |
| 60 | 2.58 | 3.87 | 5.16 | 6.45 | 7.74 | 9.03 | 10.33 | 11.62 | 12.91 | 14.20 | 15.49 | 16.78 | 18.07 | 19.36 | 20.65 | 21.94 | 23.23 | 24.52 | 25.81 |
| 66 | 2.84 | 4.26 | 5.68 | 7.10 | 8.52 | 9.94 | 11.36 | 12.78 | 14.20 | 15.62 | 17.04 | 18.46 | 19.88 | 21.30 | 22.72 | 24.13 | 25.55 | 26.97 | 28.39 |
| 72 | 3.10 | 4.65 | 6.20 | 7.74 | 9.29 | 10.84 | 12.39 | 13.94 | 15.49 | 17.04 | 18.59 | 20.13 | 21.68 | 23.23 | 24.78 | 26.33 | 27.88 | 29.43 | 30.98 |
| 78 | 3.36 | 5.03 | 6.71 | 8.39 | 10.07 | 11.74 | 13.42 | 15.10 | 16.78 | 18.46 | 20.13 | 21.81 | 23.49 | 25.17 | 26.85 | 28.52 | 30.20 | 31.88 | 33.56 |
| 84 | 3.61 | 5.42 | 7.23 | 9.03 | 10.84 | 12.65 | 14.46 | 16.26 | 18.07 | 19.88 | 21.68 | 23.49 | 25.30 | 27.10 | 28.91 | 30.72 | 32.52 | 34.33 | 36.14 |
| 90 | 3.87 | 5.81 | 7.74 | 9.68 | 11.62 | 13.55 | 15.49 | 17.42 | 19.36 | 21.30 | 23.23 | 25.17 | 27.10 | 29.04 | 30.98 | 32.91 | 34.85 | 36.78 | 38.72 |
| 96 | 4.13 | 6.20 | 8.26 | 10.33 | 12.39 | 14.46 | 16.52 | 18.59 | 20.65 | 22.72 | 24.78 | 26.85 | 28.91 | 30.98 | 33.04 | 35.11 | 37.17 | 39.24 | 41.30 |
| 102 | 4.39 | 6.58 | 8.78 | 10.97 | 13.16 | 15.36 | 17.55 | 19.75 | 21.94 | 24.13 | 26.33 | 28.52 | 30.72 | 32.91 | 35.11 | 37.30 | 39.49 | 41.69 | 43.88 |
| 108 | 4.65 | 6.97 | 9.29 | 11.62 | 13.94 | 16.26 | 18.59 | 20.91 | 23.23 | 25.55 | 27.88 | 30.20 | 32.52 | 34.85 | 37.17 | 39.49 | 41.82 | 44.14 | 46.46 |
| 114 | 4.90 | 7.36 | 9.81 | 12.26 | 14.71 | 17.17 | 19.62 | 22.07 | 24.52 | 26.97 | 29.43 | 31.88 | 34.33 | 36.78 | 39.24 | 41.69 | 44.14 | 46.59 | 49.04 |
| 120 | 5.16 | 7.74 | 10.33 | 12.91 | 15.49 | 18.07 | 20.65 | 23.23 | 25.81 | 28.39 | 30.98 | 33.56 | 36.14 | 38.72 | 41.30 | 43.88 | 46.46 | 49.04 | 51.63 |

Beginning point of WATER PENETRATION is 834 fpm
free area velocity at .01 oz. of water penetration

Water Penetration

Pressure Drop

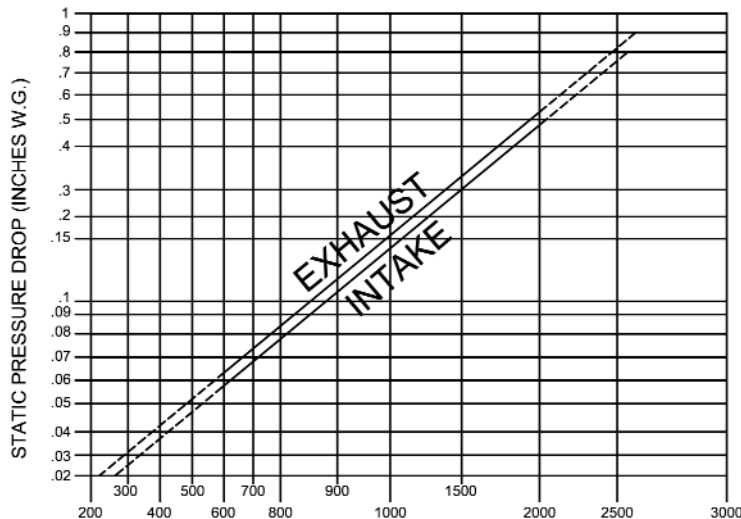

FREE AREA VELOCITY (FT/MIN)

Standard air - .075 lbs per cu ft
Ratings do not include the effect of a wire birdscreen
Test based on a 48" x 48" test size, 15 min test duration

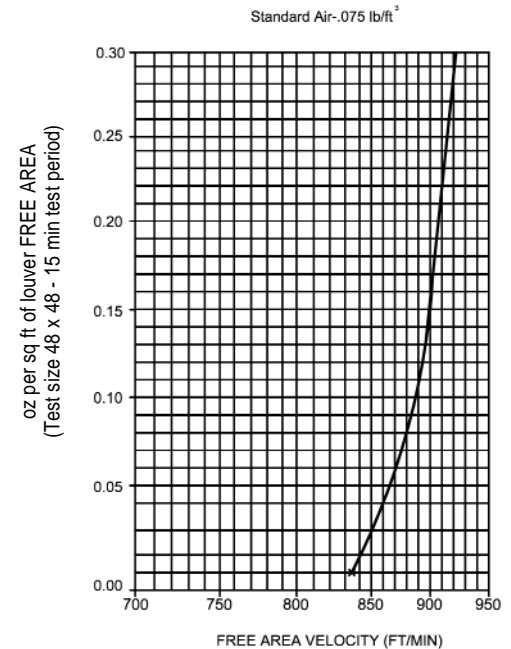

The Carnes Company certifies that the model FLGC/FKGC louver shown herein is licensed to bear the AMCA Seal. The ratings shown are based on tests and procedures performed in accordance with AMCA Publication 511 and comply with the requirements of the AMCA Certified Ratings Program. The AMCA Certified Ratings Seal applies to air performance ratings and water penetration ratings.