

Imperial [IP] Dimensions  
Metric (SI) in Parentheses

CARNES COMPANY 448 S. Main St., P. O. Box 930040, Verona, WI 53593-0040 Phone: (608)845-6411 Fax: (608)845-6504 www.carnes.com

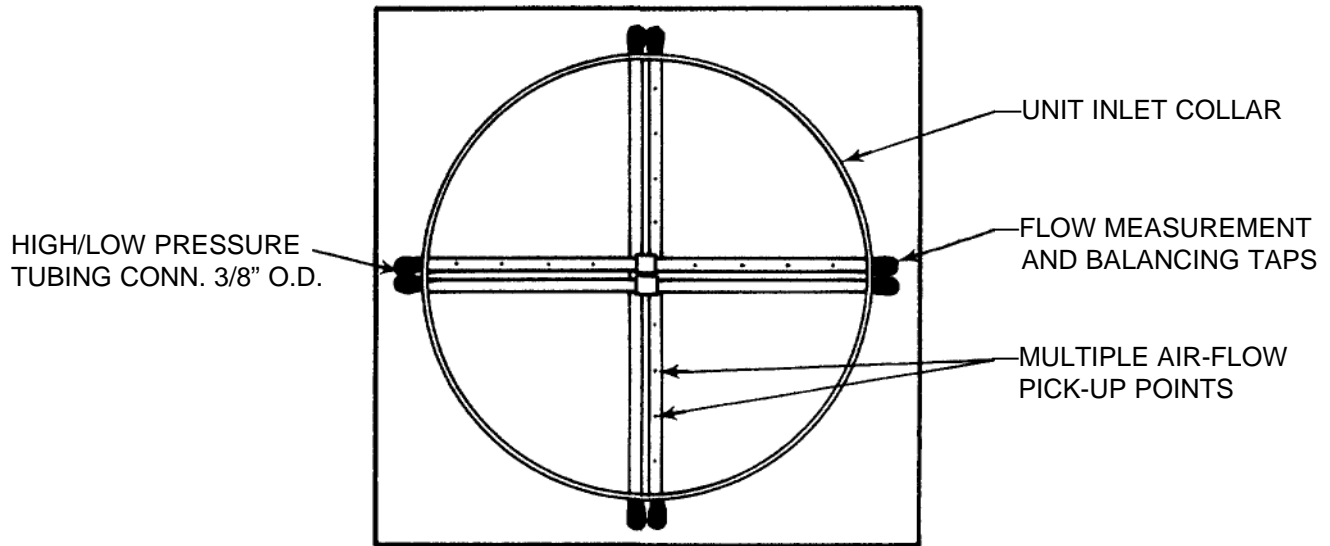

#### FEATURES:

1. The average type cross-flow sensor provides an amplified signal compatible with standard industry controls. (Pneumatic, electronic)
2. Multiple air-flow pick-up points spaced at 1" increments.
3. Sensor will perform within a 5% accuracy range with standard inlet conditions.
4. Sensor has easily accessible flow measurement and balancing taps with 3/8" O.D. tubing connections.
5. Cross-flow sensors can be used with single duct, dual duct and fan powered terminal units.