

Imperial [IP] Dimensions
Metric (SI) in Parentheses

CARNES COMPANY 448 S. Main St., P. O. Box 930040, Verona, WI 53593-0040 Phone: (608)845-6411 Fax: (608)845-6470 www.carnes.com

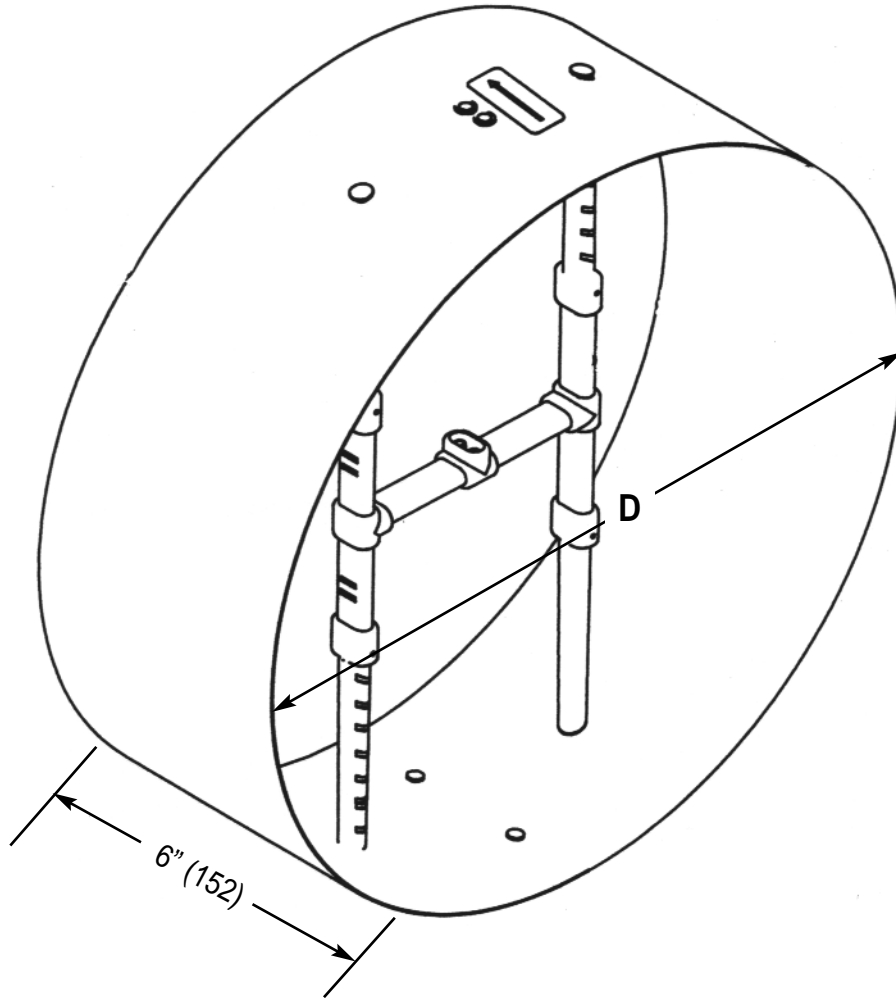

DIMENSIONS LISTED IN INCHES (Millimeters)		
Unit Size	CFM (L/s) Range	INLET
		D
05	0-350 (0-165)	4-7/8 (124)
06	0-500 (0-236)	5-7/8 (149)
07	0-700 (0-330)	6-7/8 (175)
08	0-1000 (0-472)	7-7/8 (200)
10	0-1500 (0-708)	9-7/8 (251)
12	0-2300 (0-1085)	11-7/8 (302)
14	0-3100 (0-1463)	13-7/8 (352)
16	0-4200 (0-1982)	15-7/8 (403)