

CARNES COMPANY 448 S. Main St., P. O. Box 930040, Verona, WI 53593-0040 Phone: (608)845-6411 Fax: (608)845-6504 www.carnes.com

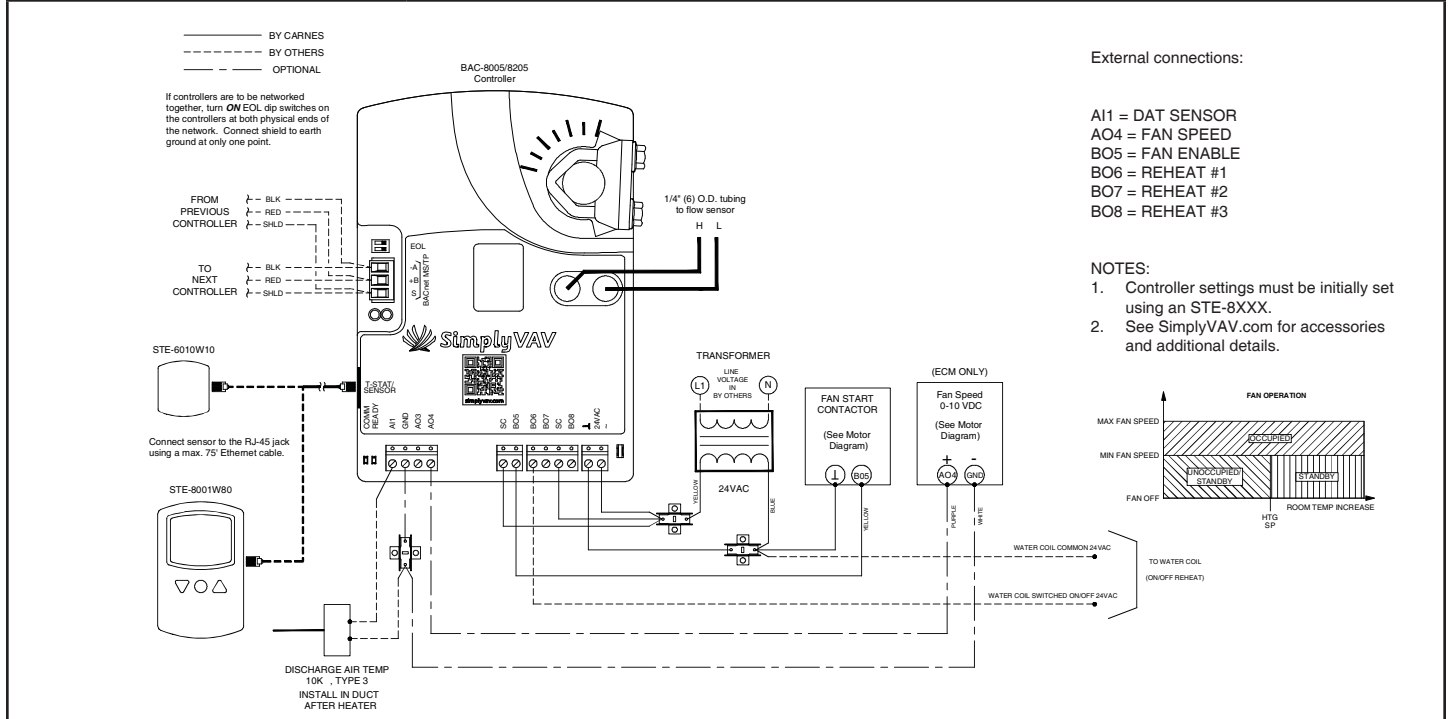

SEQUENCE OF OPERATION:

1. Changeover: If the discharge air temperature (DAT) drops below 72°F, cool air is said to be available. As the DAT rises above 76°F, warm air is said to be available. Any time warm air is available, auxiliary heat is locked out.
2. Cool air available: As space temperature rises above the cooling setpoint, the controller increases airflow. At a space temperature of 2°F above the cooling setpoint, maximum cooling airflow is maintained. On a decrease in space temperature, the controller reduces airflow. From cooling setpoint, minimum cooling airflow is maintained. If the temperature drops further and heating is required, the auxiliary flow rate is maintained.
3. Warm air available: As space temp drops below the heating setpoint, the controller increases airflow. At a temperature 2°F below the heating setpoint, maximum heating airflow is maintained. On an increase in space temperature, airflow decreases. As space temperature rises above the heating setpoint, minimum heating airflow is maintained.
4. The fan is started during occupied and standby modes. During unoccupied mode, the fan starts on a call for heating only. The fan stops only during unoccupied mode when there is no call for heat. During occupied mode, the fan runs at maximum fan speed. During standby and unoccupied modes, the fan runs at minimum fan speed.
5. As the space temp drops below the heating setpoint, stages 1, 2 and 3 of electric reheat are energized respectively. As the space temp rises back toward the heating setpoint, heating stages 3, 2 and 1 turn off respectively.
6. If DAT limiting is enabled and a DAT sensor is detected, the discharge air reheat setpoint is determined based on the heating loop. The discharge air setpoint is limited to a maximum of 15°F above space temperature.

CONTROL DIAGRAM

