

# CLEAN AIR TERMINAL - With Sterigard, Model AK **CARNES**<sup>®</sup>

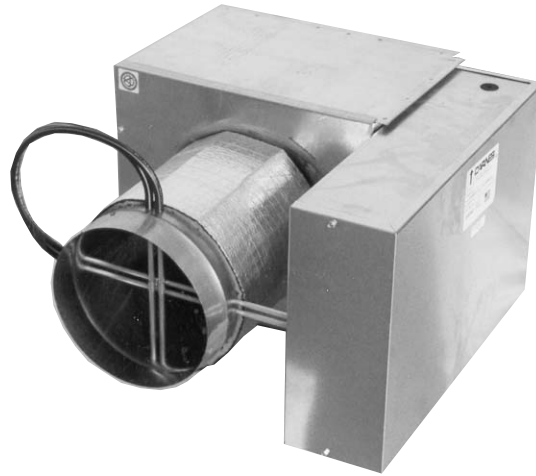
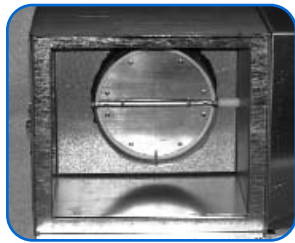
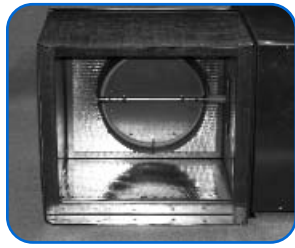

## CLEAN AIR TERMINALS with STERIGARD Models AKC, AKW and AKE

**Carnes Clean Air Terminals with STERIGARD** are designed for cooling only or cooling with reheat applications. Factory attached hot water coils or electric duct heaters are available. These units provide low pressure drop, low sound levels, and a low leakage

valve designed to control air flow and temperature within the conditioned space. These units are ideal for Hospitals, Schools, Laboratories or any other application where Indoor Air Quality concerns exist.

### *Features Include:*

- Air flow capacities from full shut-off to 4,200 CFM (0-3,000 FPM for each unit size).
- Casing insulation is a full 1" thick and has a continuous 4 lbs./cu. ft. density. The foil faced insulation is **UL** listed and meets **NFPA 90A** requirements.
- All insulation edges and seams are covered by a seam length galvanized steel channel designed to prevent any glass fiber material from entering the airstream.
- All units are provided with slip and drive connections for easy installation.
- Casing is of 22 gauge galvanized steel construction.
- Low leakage throttling damper design.
- Pneumatic, Electric, or Electronic controls options are available.
- Averaging type air flow sensor at inlet of unit.
- Optional cross flow averaging type velocity sensor at inlet of unit.
- Reheat options include: hot water coils or electric duct heaters.
- All units are **ARI** certified.



Foil Faced Insulation  
Available



A Participating Member  
in the ARI 880  
Certification Program

**Discharge and Radiated (NC) Noise Criteria**

Inlet Unit Size (Inches)	CFM	Minimum Pressure Drop (Damper Full Open)		Min. Δ Ps (Damper Full Open)			1.0" Δ Ps			1.5" Δ Ps			3.0" Δ Ps		
		Min. Δ Ps Basic Unit	Min. Δ Pt Basic unit	Δ Pt	Dis. NC Unit	Rad. NC Unit	Δ Pt	Dis. NC Unit	Rad. NC Unit	Δ Pt	Dis. NC Unit	Rad. NC Unit	Δ Pt	Dis. NC Unit	Rad. NC Unit
5	75	.03	.05	.05	—	—	1.02	10	—	1.52	12	10	3.02	18	16
	100	.04	.08	.08	—	—	1.04	12	—	1.54	15	12	3.04	21	19
	200	.17	.32	.32	—	—	1.14	16	12	1.64	19	15	3.14	24	22
	300	.39	.71	.71	—	11	1.33	19	17	1.83	22	18	3.33	28	24
	350	.53	.97	.97	—	14	1.44	20	19	1.94	23	20	3.44	29	24
6	110	.02	.04	.04	—	—	1.02	10	15	1.52	15	20	3.02	22	27
	200	.05	.12	.12	—	—	1.07	12	16	1.57	16	21	3.07	23	28
	300	.11	.26	.26	—	—	1.15	14	17	1.65	17	21	3.15	24	28
	400	.20	.46	.46	—	—	1.27	15	18	1.77	18	22	3.27	25	28
	500	.30	.72	.72	—	—	1.42	15	19	1.92	18	22	3.42	25	30
7	140	.01	.03	.03	—	—	1.02	15	15	1.52	19	20	3.02	27	30
	200	.03	.06	.06	—	—	1.04	15	15	1.54	19	21	3.04	27	30
	400	.10	.24	.24	—	—	1.14	15	16	1.64	19	21	3.14	27	31
	600	.20	.52	.52	—	—	1.32	15	18	1.82	19	22	3.32	28	31
	700	.27	.71	.71	—	—	1.44	16	19	1.94	19	22	3.44	28	31
8	185	.01	.03	.03	—	—	1.02	10	16	1.52	14	22	3.02	21	30
	400	.04	.12	.12	—	—	1.08	11	17	1.58	16	22	3.08	22	30
	600	.08	.26	.26	—	—	1.18	12	18	1.68	16	22	3.18	23	30
	800	.14	.46	.46	—	—	1.32	14	18	1.82	17	22	3.32	24	30
	1000	.20	.71	.71	—	—	1.50	14	20	2.00	18	23	3.50	24	30
10	300	.00	.02	.02	—	—	1.02	18	27	1.52	23	31	3.02	31	40
	500	.01	.06	.06	—	—	1.05	18	25	1.55	23	30	3.05	31	39
	800	.03	.15	.15	—	—	1.13	18	25	1.63	23	30	3.13	31	38
	1200	.06	.34	.34	—	—	1.28	18	24	1.78	23	29	3.28	30	37
	1500	.09	.53	.53	—	—	1.44	17	24	1.94	22	29	3.44	30	37
12	430	.01	.02	.02	—	—	1.02	11	22	1.52	17	28	3.02	25	38
	800	.02	.08	.08	—	—	1.06	11	22	1.56	17	28	3.06	25	38
	1200	.03	.17	.17	—	—	1.14	11	22	1.64	17	28	3.14	25	37
	1800	.07	.38	.38	—	—	1.31	11	24	1.81	17	27	3.31	25	37
	2300	.11	.61	.61	—	13	1.50	11	26	2.00	17	30	3.50	25	37
14	600	.00	.02	.02	—	—	1.02	—	19	1.52	15	25	3.02	24	35
	1000	.01	.05	.05	—	—	1.05	—	21	1.55	15	27	3.05	24	36
	1600	.01	.13	.13	—	—	1.12	10	22	1.62	15	27	3.12	24	37
	2400	.02	.28	.28	—	13	1.26	10	22	1.76	16	28	3.26	25	37
	3100	.02	.46	.46	—	19	1.44	10	23	1.94	16	28	3.44	25	38
16	780	.00	.02	.02	—	—	1.02	—	22	1.52	14	28	3.02	23	36
	1600	.01	.08	.08	—	—	1.07	—	23	1.57	14	28	3.07	23	37
	2400	.01	.17	.17	—	—	1.16	—	23	1.66	14	28	3.16	23	37
	3600	.02	.37	.37	—	19	1.35	—	23	1.85	15	28	3.35	24	37
	4200	.02	.50	.50	—	23	1.48	10	24	1.98	15	29	3.48	24	37

- NOTES:**
1. Δ Ps static pressure difference from inlet to discharge.
  2. Δ Ps is the minimum pressure required to deliver CFM shown with the primary damper in wide open position.
  3. Δ Pt is the total pressure difference from inlet to discharge.
  4. Dash (—) indicates NC level less than 10.

NC levels are derived from tests conducted in accordance with ARI Standard 880-98 and are calculated in accordance with ARI Standard 885-98 as application data based on the following:

**Discharge NC levels are based on —**

- a) 5 foot rectangular 12" x 12" duct lined with 1" fiberglass insulation.
- b) Rectangular tee attenuation entering branch duct.
- c) 6 foot lined flex duct (8" diameter).
- d) Maximum of 300 CFM per outlet.
- e) Space effect factor (5000 ft<sup>3</sup>) at 5 feet from outlet.
- f) End reflection.

**Radiated NC levels are based on—**

- a) Plenum / ceiling effect - 5/8" mineral fiber tile, 35 lb / ft<sup>2</sup> - 3 foot plenum.
- b) Space effect factor (5000 ft<sup>3</sup>) at 10 feet from source.
- c) Environmental adjustment factor.



A Participating Member in the ARI 880 Certification Program

## Discharge Sound Power

Inlet Size (Inches)	CFM	Minimum $\Delta P_s$							1.0" $\Delta P_s$							1.5" $\Delta P_s$							3.0" $\Delta P_s$						
		Sound Power (db) by Octave Band							Sound Power (db) by Octave Band							Sound Power (db) by Octave Band							Sound Power (db) by Octave Band						
		$\Delta P_s$	(2)	(3)	(4)	(5)	(6)	(7)	(2)	(3)	(4)	(5)	(6)	(7)	(2)	(3)	(4)	(5)	(6)	(7)	(2)	(3)	(4)	(5)	(6)	(7)			
5	75	.03	39	28	22	20	18	20	52	56	51	44	43	40	53	58	55	49	48	45	55	63	63	58	56	54			
	100	.04	43	33	28	25	22	22	56	58	52	46	44	41	57	60	57	51	49	46	59	65	65	60	58	55			
	200	.17	53	44	42	37	34	29	65	61	56	50	48	43	66	64	61	55	53	48	69	68	68	64	61	57			
	300	.39	58	51	50	44	41	34	70	64	58	52	50	45	72	66	63	57	55	50	74	71	71	66	63	59			
	350	.53	60	53	53	46	43	35	72	65	59	53	51	45	74	67	64	58	56	50	76	72	71	67	64	59			
6	110	.02	35	25	19	18	15	20	55	59	58	55	53	48	57	63	63	60	57	53	60	69	71	68	66	63			
	200	.05	42	35	31	29	25	25	61	61	60	55	52	48	63	64	64	60	57	53	65	70	72	69	66	63			
	300	.11	46	41	39	37	32	29	65	62	61	56	52	48	66	65	65	61	57	53	69	71	73	69	65	63			
	400	.20	50	46	45	43	37	31	67	63	61	56	52	48	69	66	66	61	57	53	72	72	74	70	65	63			
	500	.30	52	49	49	47	41	33	70	63	62	56	52	48	71	66	66	61	57	57	74	72	74	70	65	63			
7	140	.01	35	24	18	17	14	18	57	63	57	53	51	48	58	67	63	58	55	52	60	73	73	66	62	60			
	200	.03	40	30	25	24	21	22	60	63	58	53	51	48	61	67	63	58	56	52	63	73	73	66	63	60			
	400	.10	49	41	40	37	34	30	66	63	58	54	52	48	67	67	64	59	56	53	68	73	74	67	63	60			
	600	.20	54	48	48	45	41	34	69	63	58	54	52	49	70	67	64	59	57	53	72	74	74	68	64	61			
	700	.27	56	51	51	48	44	36	70	64	58	54	53	49	71	67	64	59	57	53	73	74	74	68	64	61			
8	185	.01	37	24	20	19	17	18	57	61	57	53	48	45	58	64	62	57	53	50	60	70	71	66	60	58			
	400	.04	44	36	35	33	29	27	62	62	59	54	50	47	63	66	64	59	54	52	64	71	72	67	62	60			
	600	.08	47	43	43	41	35	31	64	63	59	55	52	48	65	66	64	60	55	53	67	72	73	68	64	61			
	800	.14	50	47	48	46	39	34	66	64	60	56	52	49	67	67	65	61	56	54	69	73	73	69	64	62			
	1000	.20	51	51	52	51	43	37	67	64	60	57	53	50	68	68	65	61	57	54	70	73	74	70	65	62			
10	300	.01	35	23	18	17	15	17	62	69	65	63	57	51	63	73	71	68	62	56	65	80	81	76	71	64			
	500	.01	40	31	30	28	24	23	64	69	65	63	58	52	65	73	71	68	62	57	67	80	81	76	71	65			
	800	.03	44	39	41	38	32	29	66	69	64	63	58	52	67	73	70	67	63	57	69	80	81	76	71	65			
	1200	.06	47	46	50	46	40	34	67	69	64	62	58	53	69	73	70	67	63	58	70	79	80	75	71	66			
	1500	.09	49	49	55	51	44	37	68	68	64	62	58	53	69	72	70	67	63	58	71	79	80	75	71	66			
12	430	.01	35	24	20	18	15	15	62	65	62	63	58	51	65	70	67	67	63	56	69	77	76	76	70	64			
	800	.02	42	34	35	30	27	25	64	65	62	63	58	51	67	70	67	67	62	56	71	77	76	75	69	65			
	1200	.03	46	41	45	37	35	31	66	65	62	62	58	51	68	70	67	67	62	56	73	77	76	75	69	65			
	1800	.07	50	48	55	45	43	37	67	65	62	62	57	51	70	70	67	66	62	57	74	77	76	74	69	65			
	2300	.11	53	52	61	50	47	41	68	65	62	62	57	52	70	70	68	66	62	57	75	77	76	74	69	65			
14	600	.01	38	27	19	18	16	16	62	64	59	63	61	51	65	69	64	68	65	57	70	77	73	76	74	67			
	1000	.01	45	36	34	29	26	24	64	64	61	64	60	52	67	69	66	68	65	58	73	77	75	76	73	68			
	1600	.01	50	45	47	39	35	31	67	65	63	64	60	52	70	69	68	68	65	58	75	77	77	76	73	68			
	2400	.02	55	52	58	47	44	36	69	65	65	64	60	53	72	70	70	69	64	59	77	77	78	77	73	69			
	3100	.02	58	56	65	52	49	40	70	65	66	64	59	53	73	70	71	69	64	59	79	78	79	77	72	69			
16	780	.01	41	31	24	23	18	17	67	62	65	67	61	56	70	67	69	72	66	62	76	75	77	79	74	71			
	1600	.01	53	45	44	36	32	29	69	64	65	66	61	56	72	68	70	71	66	62	79	76	77	78	74	71			
	2400	.02	60	52	55	44	41	36	70	64	65	66	61	56	74	69	70	70	66	62	80	77	77	77	74	71			
	3600	.04	67	60	66	52	49	43	71	65	66	65	61	56	75	70	70	70	66	62	81	78	78	77	74	71			
	4200	.05	70	63	70	55	52	45	72	66	66	65	61	56	75	70	70	69	66	62	81	78	78	77	74	71			

- NOTES:**
1. Based on tests conducted in accordance with ARI Standard 880-98.
  2.  $\Delta P_s$  static pressure difference from inlet to discharge.
  3.  $\Delta P_s$  is the minimum pressure required to deliver CFM shown with primary damper in wide open position.



A Participating Member  
in the ARI 880  
Certification Program

**Radiated Sound Power**

Inlet Size (Inches)	CFM	Minimum Δ Ps							1.0" Δ Ps							1.5" Δ Ps							3.0" Δ Ps						
		Sound Power (db) by Octave Band							Sound Power (db) by Octave Band							Sound Power (db) by Octave Band							Sound Power (db) by Octave Band						
		Δ Ps	(2)	(3)	(4)	(5)	(6)	(7)	(2)	(3)	(4)	(5)	(6)	(7)	(2)	(3)	(4)	(5)	(6)	(7)	(2)	(3)	(4)	(5)	(6)	(7)			
5	75	.03	38	29	19	18	18	20	44	43	39	31	31	26	45	45	42	35	35	32	47	48	48	41	43	41			
	100	.04	42	32	24	20	19	21	47	45	40	31	31	27	49	47	44	35	36	32	51	50	50	42	44	42			
	200	.17	46	39	36	26	24	22	55	50	43	33	33	29	57	52	47	37	37	34	59	55	53	44	45	44			
	300	.39	49	43	43	29	26	23	60	53	45	34	33	30	61	55	49	38	38	35	63	58	55	45	46	45			
	350	.53	50	44	46	30	27	24	62	54	46	34	34	30	63	56	50	38	39	36	65	59	55	45	47	45			
6	110	.02	36	27	19	17	17	20	46	51	47	37	32	29	47	54	51	41	37	34	49	59	58	49	45	42			
	200	.05	40	34	25	23	21	21	52	53	48	38	34	30	53	56	52	42	38	35	55	60	59	50	46	43			
	300	.11	43	38	29	26	24	22	57	54	48	38	35	31	57	57	52	43	39	36	59	61	59	51	47	44			
	400	.20	45	41	32	28	26	23	59	55	49	39	35	32	60	58	53	44	40	37	62	62	59	52	48	45			
	500	.30	47	44	34	30	27	23	62	55	49	39	36	32	63	58	53	44	40	37	64	63	60	52	48	45			
7	140	.01	37	27	19	18	17	21	48	52	46	36	32	29	49	55	51	41	37	34	51	62	60	48	44	42			
	200	.03	39	30	23	21	19	21	51	52	46	36	33	29	52	56	52	41	37	34	54	62	60	49	45	43			
	400	.10	45	36	30	27	23	22	57	53	46	37	34	31	58	57	52	41	39	36	60	63	61	49	46	44			
	600	.20	48	40	35	30	25	23	61	54	47	37	35	31	62	58	52	41	40	36	64	64	61	49	47	45			
	700	.27	49	41	36	31	26	23	62	54	47	37	35	32	63	58	52	41	40	37	65	64	61	49	47	45			
8	185	.01	36	26	17	16	16	20	51	53	48	35	32	29	52	56	53	39	36	33	53	60	60	47	44	42			
	400	.04	42	33	28	25	22	22	56	54	48	36	34	30	57	57	53	41	38	35	59	62	60	49	46	43			
	600	.08	45	36	33	29	25	23	59	55	48	37	35	31	60	58	53	42	39	36	62	62	60	50	47	44			
	800	.14	48	39	37	32	27	23	61	55	48	38	35	32	62	58	53	42	40	36	64	63	60	50	48	45			
	1000	.20	49	41	40	35	29	24	63	56	48	38	36	32	64	59	53	43	40	37	65	63	60	51	48	45			
10	300	.01	37	30	19	17	17	21	55	62	55	46	38	34	57	66	60	51	43	39	60	73	70	59	52	47			
	500	.01	40	33	26	23	21	22	58	61	54	46	39	35	59	65	59	51	44	40	62	72	69	59	52	48			
	800	.03	43	37	32	28	24	23	60	61	53	46	40	36	62	65	58	51	45	40	64	72	68	59	53	48			
	1200	.06	46	40	37	33	27	24	62	60	52	46	40	36	64	64	58	51	45	41	66	71	67	59	54	49			
	1500	.09	47	41	40	35	29	25	63	60	52	46	41	36	65	64	57	51	45	41	67	71	67	59	54	49			
12	430	.01	38	25	16	17	15	18	57	58	50	43	36	32	60	63	55	48	40	37	65	72	64	56	48	44			
	800	.02	42	32	27	24	23	22	61	58	50	43	37	34	64	63	55	48	42	39	68	72	64	56	48	46			
	1200	.03	45	37	34	29	27	26	63	58	49	43	38	36	66	63	55	48	43	40	71	71	64	56	50	47			
	1800	.07	47	42	41	34	32	29	66	57	49	43	39	37	68	62	54	48	44	41	73	71	63	56	51	48			
	2300	.11	49	45	45	37	35	31	67	57	49	43	40	37	70	62	54	48	44	42	75	71	63	56	52	49			
14	600	.01	38	27	16	16	15	19	55	56	49	44	37	33	58	61	54	49	42	38	63	69	62	58	50	46			
	1000	.01	41	33	27	23	21	22	58	57	51	45	38	35	61	62	55	50	43	39	66	70	64	58	51	47			
	1600	.01	44	39	37	29	26	24	61	58	52	45	40	36	64	62	57	50	44	40	69	71	65	58	52	48			
	2400	.02	47	44	45	34	31	26	64	58	53	45	41	37	67	63	58	50	45	41	72	71	66	59	53	49			
	3100	.02	48	47	50	37	34	28	65	58	53	46	41	38	68	63	58	51	46	42	73	72	66	59	54	50			
16	780	.01	37	28	17	16	15	18	54	58	53	48	43	39	59	63	57	52	47	43	66	70	64	59	54	50			
	1600	.01	42	38	33	27	25	24	58	59	54	49	45	40	62	63	58	53	49	45	69	71	65	59	56	52			
	2400	.01	46	44	41	33	31	27	60	59	54	50	46	41	64	63	58	53	50	45	71	71	65	60	57	52			
	3600	.02	49	50	50	39	36	31	62	59	54	50	47	42	66	63	59	54	51	46	73	71	66	60	58	53			
	4200	.02	50	52	54	41	38	32	62	59	55	50	47	42	67	64	59	54	52	46	74	71	66	60	59	53			

- NOTES:**
1. Based on tests conducted in accordance with ARI Standard 880-98.
  2. Δ Ps static pressure difference from inlet to discharge.
  3. Δ Ps is the minimum pressure required to deliver CFM shown with primary damper in wide open position.



A Participating Member  
in the ARI 880  
Certification Program

# MODEL NUMBERING SYSTEM - Model AKE

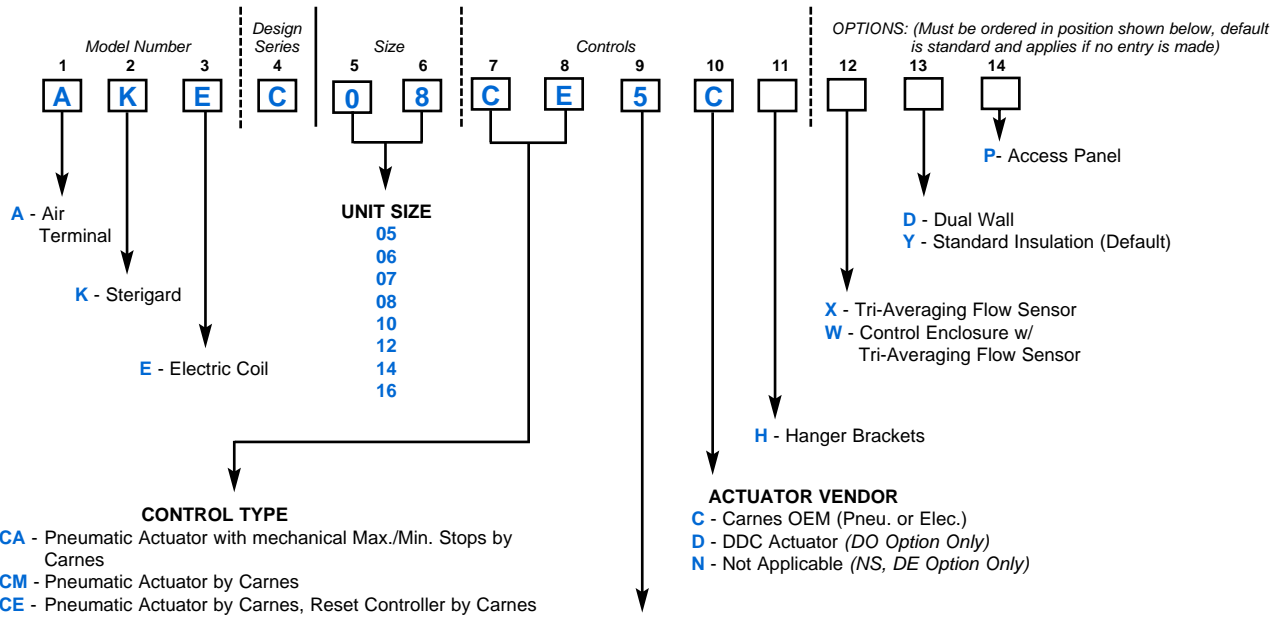

- CONTROL TYPE**
- CA - Pneumatic Actuator with mechanical Max./Min. Stops by Carnes
  - CM - Pneumatic Actuator by Carnes
  - CE - Pneumatic Actuator by Carnes, Reset Controller by Carnes
  - CX - Pneumatic Actuator by Carnes, (Multi-function) Reset Controller by Carnes
  - ER - Electric Actuator with Reheat Switch by Carnes (Enclosure Included)
  - EK - Electric Actuator with (2) Reheat Switches by Carnes (Enclosure Included)
  - ET - Analog Electronic Velocity Controller with Integral Damper Actuator
  - DO - DDC Provided by Others, Mounted and Wired by Carnes, w/ Carnes Inlet Sensor, w/3/8" Damper Shaft, w/Enclosure
  - DE - DDC Enclosure w/Carnes Inlet Sensor, w/Bare 3/8" Damper Shaft
  - NS - No Damper Controls, w/Carnes Inlet Sensor, w/Bare 3/8" Damper Shaft (No Enclosure)

- ACTUATOR VENDOR**
- C - Carnes OEM (Pneu. or Elec.)
  - D - DDC Actuator (DO Option Only)
  - N - Not Applicable (NS, DE Option Only)
- CONTROLS, DAMPERS AND COIL ARRANGEMENTS**
- \*1 - Normally Open - Right Hand Controls  
(All Electric/Electronic/Manual Control Types/DO, DE, NS)  
(All Pneumatic Control Types for Reverse Acting Thermostat)
  - \*2 - Normally Open - Left Hand Controls  
(All Electric/Electronic/Manual Control Types/DO, DE, NS)  
(All Pneumatic Control Types for Reverse Acting Thermostat)
  - 3 - Normally Closed - Right Hand Controls  
(All Pneumatic Control Types for Direct Acting Thermostat)
  - 4 - Normally Closed - Left Hand Controls  
(All Pneumatic Control Types for Direct Acting Thermostat)
  - 5 - Normally Open - Right Hand Controls  
(All Pneumatic Control Types for Direct Acting Thermostat)
  - 6 - Normally Open - Left Hand Controls  
(All Pneumatic Control Types for Direct Acting Thermostat)
  - 7 - Normally Closed - Right Hand Controls  
(All Pneumatic Control Types for Reverse Acting Thermostat)
  - 8 - Normally Closed - Left Hand Controls  
(All Pneumatic Control Types for Reverse Acting Thermostat)

**NOTE:** Hand of controls is determined by facing the averaging flow sensor (inlet of the unit) with the supply air hitting the back of your head.

\* Electric, Electronic and DDC Units **DO NOT** fail open. '1' or '2' is used for Right or Left Hand Only. Electric/Electronic Units are shipped with the Damper in the Open Position.

## ▼ Electric Thermostat

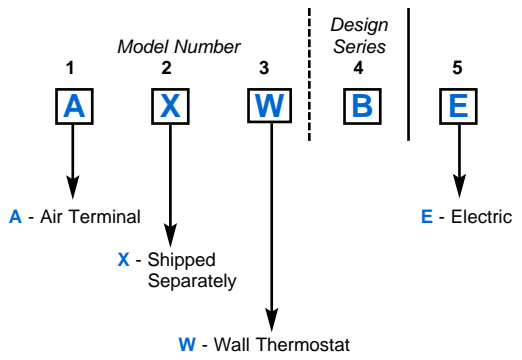

A Carnes Electric Thermostat **must be ordered** with the Electric ER and EK Control Options.

## ▼ Electronic Thermostat

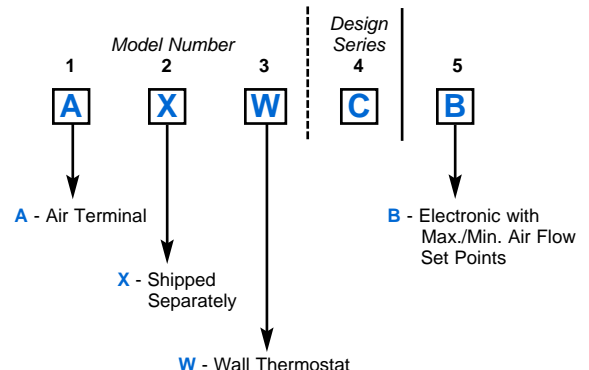

A Carnes Electronic Thermostat **must be ordered** with the ET Electronic Control Option.

LEFT HAND UNIT SHOWN  
RIGHT HAND AVAILABLE

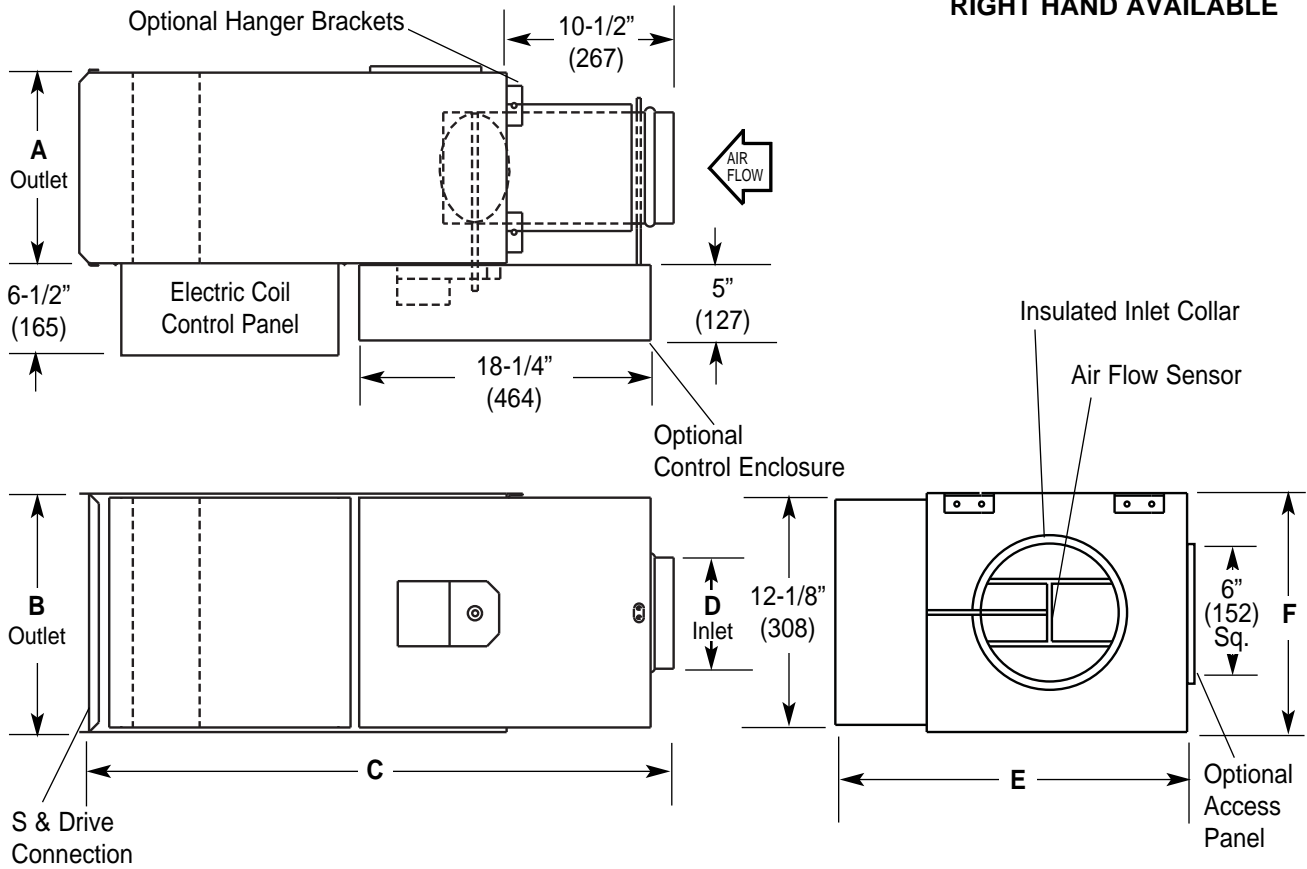

DIMENSIONS LISTED IN INCHES (Metric In Millimeters)							
Unit Size	CFM (L/s) Range	Outlet		C	Inlet		F
		A	B		D	E	
05	0-350 (0-165)	12 (305)	10 (254)	44-3/8 (1127)	4-7/8 (124)	18-1/2 (470)	10-1/8 (257)
06	0-500 (0-236)	12 (305)	10 (254)	44-3/8 (1127)	5-7/8 (149)	18-1/2 (470)	10-1/8 (257)
07	0-700 (0-330)	14 (356)	12-1/2 (318)	44-3/8 (1127)	6-7/8 (175)	20-1/2 (521)	12-5/8 (320)
08	0-1000 (0-472)	14 (356)	12-1/2 (318)	44-3/8 (1127)	7-7/8 (200)	20-1/2 (521)	12-5/8 (320)
10	0-1500 (0-708)	16 (406)	15 (381)	44-3/8 (1127)	9-7/8 (251)	22-1/2 (572)	15-1/8 (384)
12	0-2300 (0-1085)	20 (508)	17-1/2 (445)	44-3/8 (1127)	11-7/8 (302)	26-1/2 (673)	17-5/8 (447)
14	0-3100 (0-1463)	20 (508)	17-1/2 (445)	44-3/8 (1127)	13-7/8 (352)	26-1/2 (673)	17-5/8 (447)
16	0-4200 (0-1982)	24 (610)	20 (508)	44-3/8 (1127)	15-7/8 (403)	30-1/2 (775)	20-1/8 (511)