

Models ASF w/o Reheat
 ASW w/Hot Water Reheat
 ASE w/Electric Reheat

The Carnes intermittent fan terminal unit provides constant air volume to the space for reheat applications while retaining a variable air volume system during normal cooling operation. The primary air control assembly operates independently as a standard throttling valve for cooling loads. As cooling loads diminish, the secondary air supply fan(s) is energized to induce warm ceiling plenum air. A wide variety of control sequences makes this fan powered unit compatible with the most energy efficient system design.

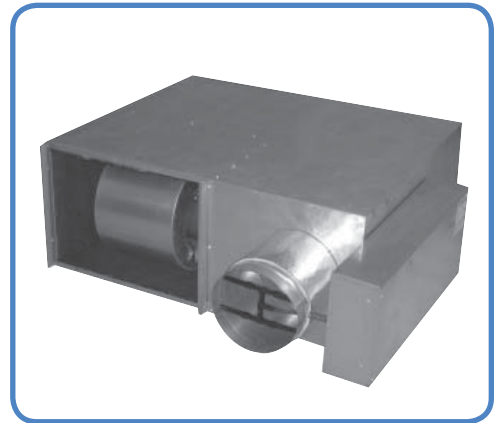

Features Include:

- Seventeen unit/inlet size variations offering air flow capacities to 4200 CFM primary air and 1870 CFM secondary air with low pressure drop and low sound levels.
- Durable 22 gauge galvanized steel casing construction.
- Bottom access panel for internal components.
- Flange or slip and drive discharge connections.
- Forward curved centrifugal type fan assemblies with thermally protected, Permanent Split Capacitor type 120 or 277 volt fractional horsepower motors.
- Fan/motor assemblies are isolated from the casing using rubber isolators to minimize vibration transmission.
- Adjustable SCR fan speed control.
- Field adjustable P/E switch with pneumatic controls.
- Performance data based on tests conducted in accordance with AHRI Standard 880-2008.
- Tri-Averaging type velocity sensor and calibration chart for measuring primary air flow.
- Secondary air filter rack.
- All units equipped with pneumatic or electronic pressure independent controls.
- Insulation is 1" thick, 1-1/2 lb. dual density fiberglass with surface treatment to prevent air erosion. UL listed and meets NFPA 90A requirements.
- Damper controls and fan controls are located in one enclosure.
- Low leakage primary air damper design.
- AHRI listed.
- Optional ETL listing.
- Optional secondary air sound baffle. Sound baffle is factory attached to secondary air inlet. (Contact Carnes.)
- Optional one to four row hot water coils (Model ASW). Coil is factory attached to primary air discharge.
- Optional electric reheat coils (Model ASE). Coil is factory attached to primary air discharge.
- Optional secondary air filters, Class I (re-usable) and Class II (throw away).
- Optional non-fused or fused fan disconnect switch.
- Optional foil coated insulation.
- Optional fiber-free liner.

Available Modules:

- Basic control unit — **Model ASF.**
- Basic control unit with hot water coil — **Model ASW.**
- Basic control unit with or without electric coil — **Model ASE.**



IAQ Insulation
 Available

FAN CURVES CFM vs EXTERNAL STATIC PRESSURE

FAN SIZE A — AS 05, 06, 07
1/6 H.P. Motor

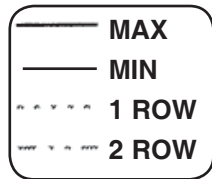
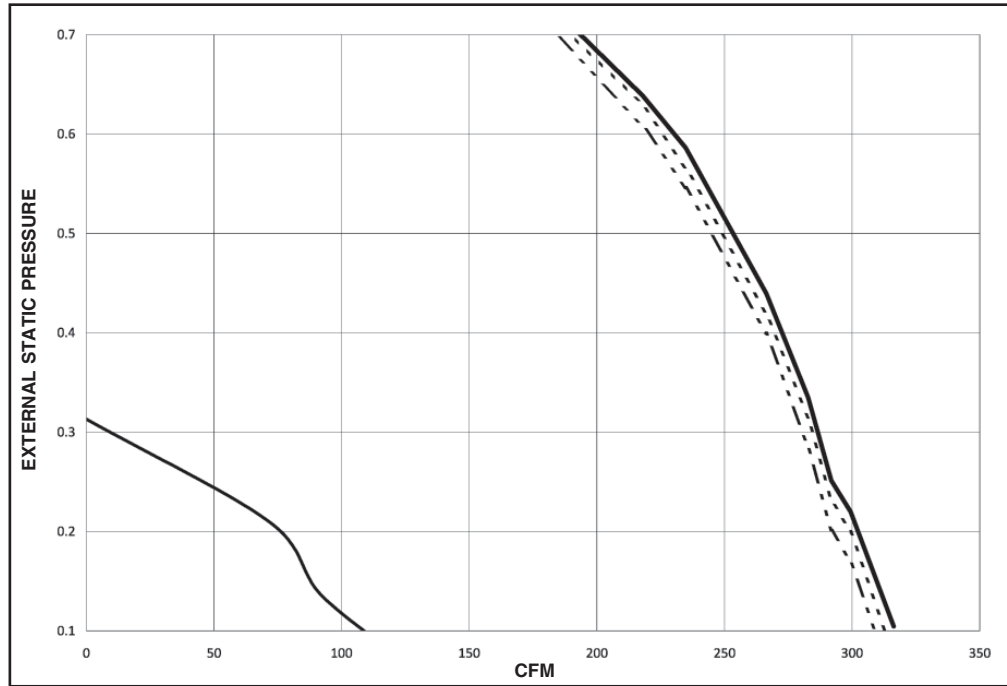

FAN SIZE B — AS 06, 07, 08
1/6 H.P. Motor

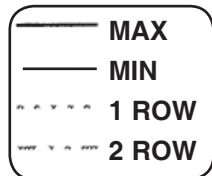
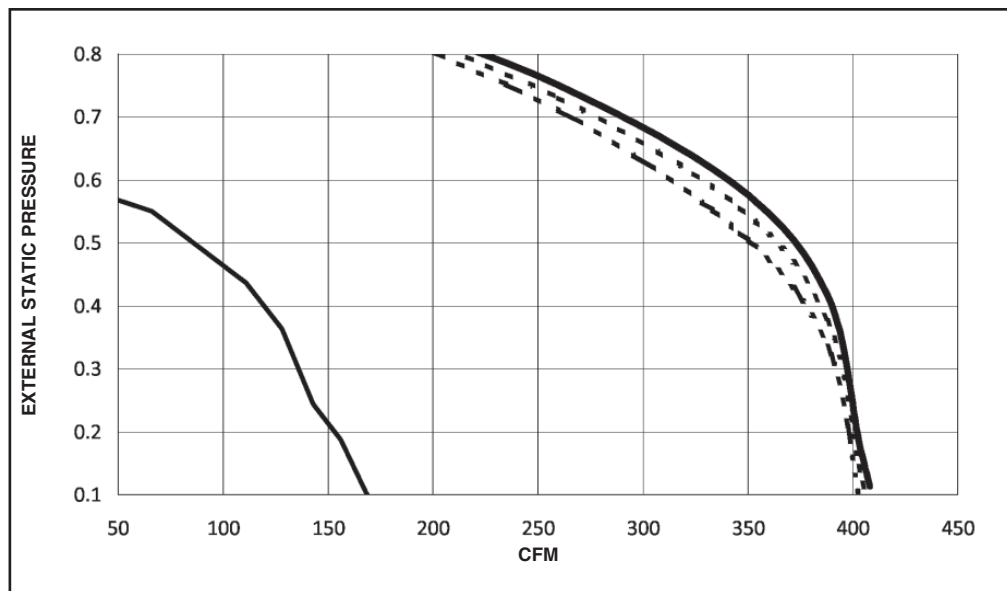

- NOTES: 1. External Static Pressure (ESP) consists of down stream ductwork, coils, flex, duct, etc.
2. Pressure drop due to heating coils are treated as external static pressure.
3. For proper operation, the downstream ESP must be at least 0.20" w.g.

FAN CURVES CFM vs EXTERNAL STATIC PRESSURE

FAN SIZE C — AS 07, 08, 10
1/6 H.P. Motor

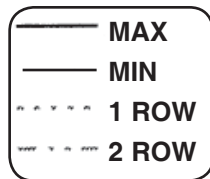
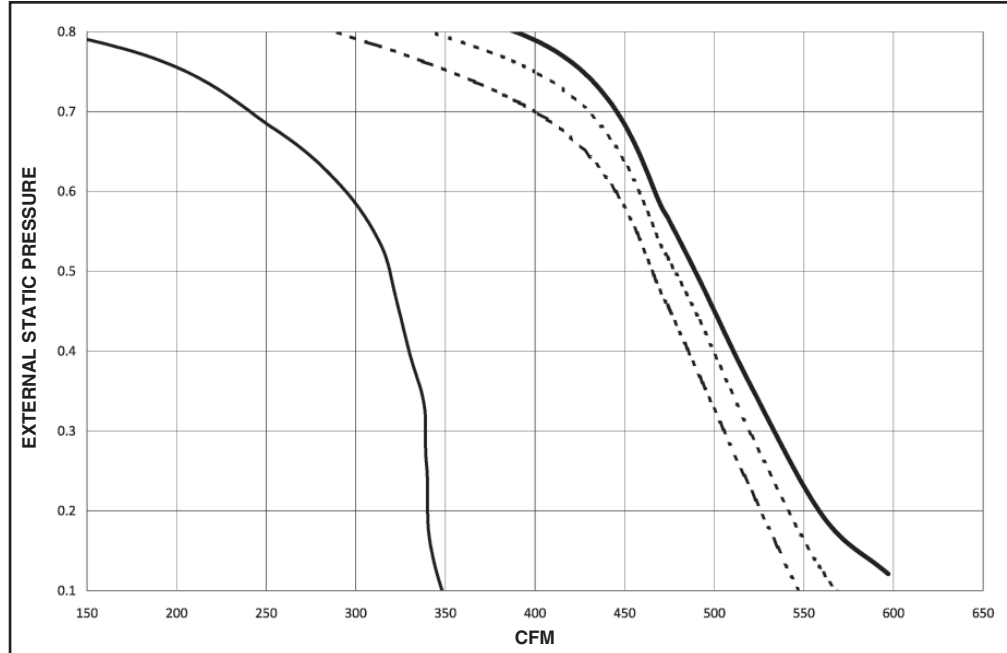

FAN SIZE D — AS 08, 10
1/4 H.P. Motor

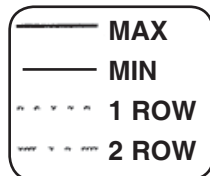
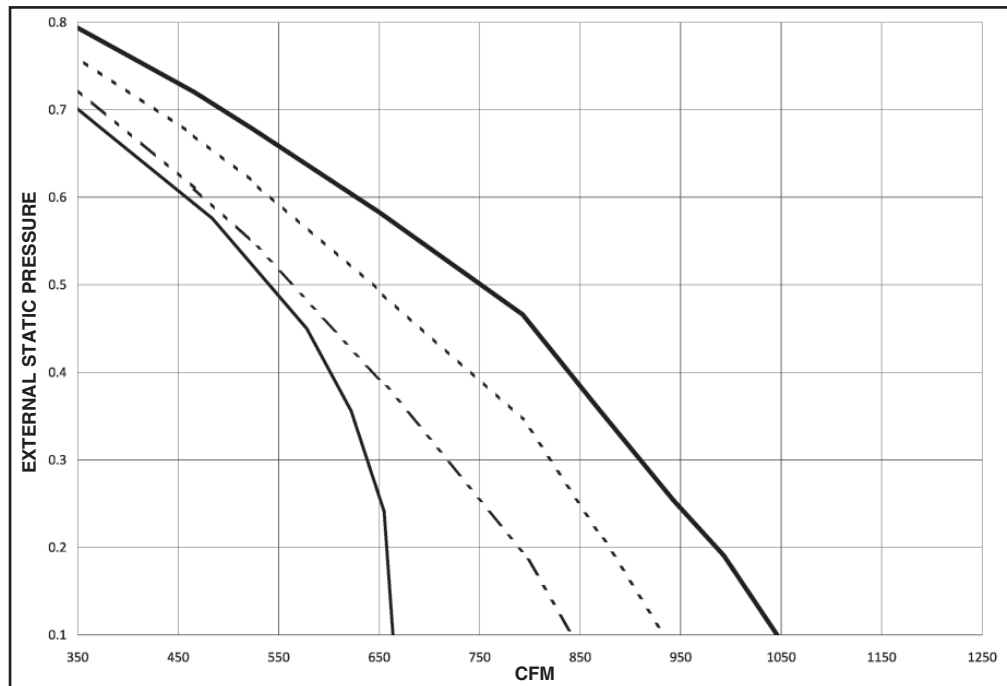

- NOTES:
1. External Static Pressure (ESP) consists of down stream ductwork, coils, flex, duct, etc.
 2. Pressure drop due to heating coils are treated as external static pressure.
 3. For proper operation, the downstream ESP must be at least 0.20" w.g.

FAN CURVES CFM vs EXTERNAL STATIC PRESSURE

FAN SIZE E — AS 10, 12, 14
1/4 H.P. Motor

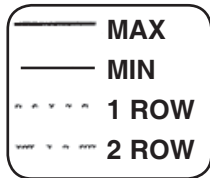
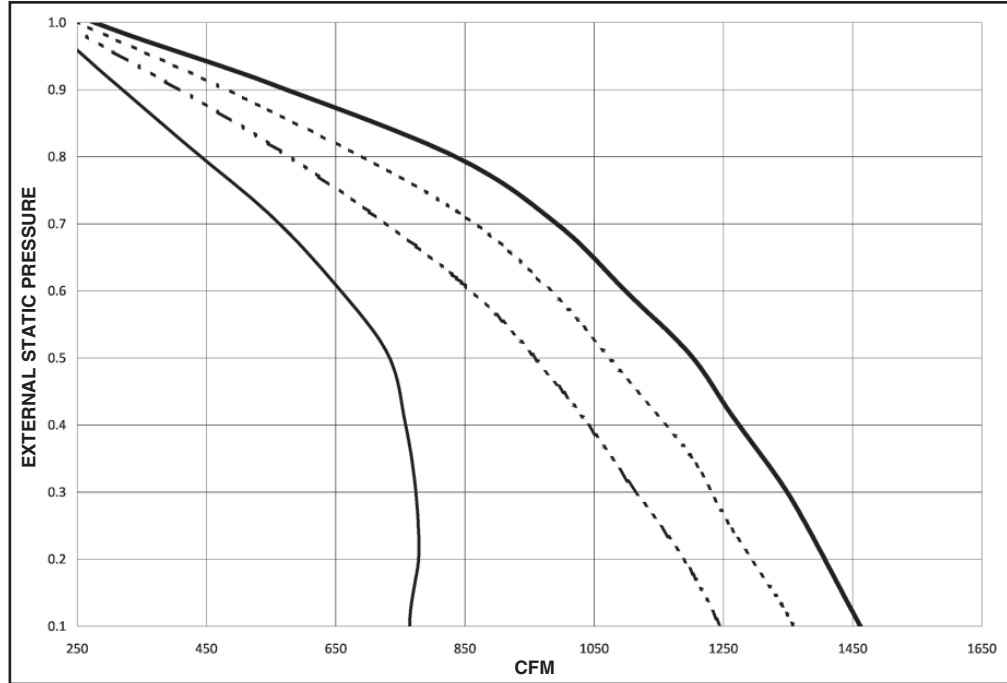

FAN SIZE F — AS 12, 14, 16
1/2 H.P. Motor

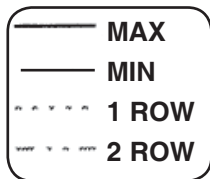
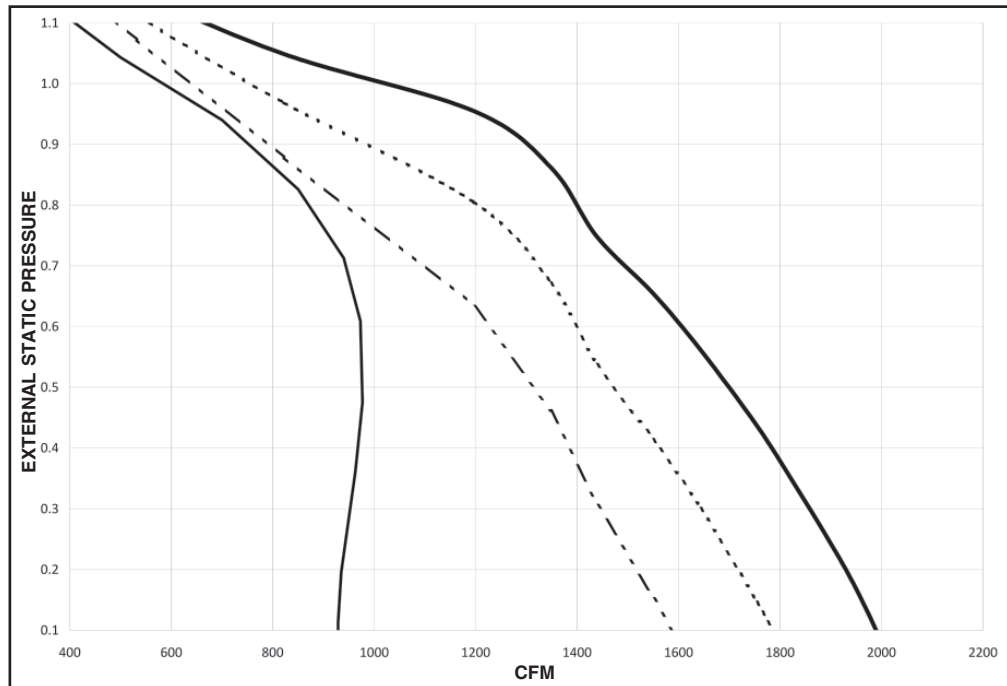

- NOTES: 1. External Static Pressure (ESP) consists of down stream ductwork, coils, flex, duct, etc.
 2. Pressure drop due to heating coils are treated as external static pressure.
 3. For proper operation, the downstream ESP must be at least 0.20" w.g.

Fan Powered Units

**DISCHARGE AND RADIATED Noise Criteria
(Fan Off -100% Primary Air)**

Model AS_H

Inlet (Fan) Size	CFM	Minimum Pressure Drop ΔPs			Minimum ΔPs		1.0" ΔPs		1.5" ΔPs		3.0" ΔPs	
		Base Unit	1-Row	2-Row	Dis NC	Rad NC	Dis NC	Rad NC	Dis NC	Rad NC	Dis NC	Rad NC
5 (A)	75	.017	.021	.019	—	—	—	—	—	—	—	—
	100	.028	.033	.030	—	—	—	—	—	—	—	—
	200	.115	.128	.191	—	—	—	—	—	—	10	—
	300	.248	.275	.274	—	—	15	—	17	—	18	—
	350	.346	.375	.385	—	—	14	10	14	10	17	11
6 (A,B)	110	.011	.016	.019	—	—	—	—	—	—	—	—
	200	.045	.054	.064	—	—	—	—	—	—	—	10
	300	.091	.071	.124	—	—	—	—	10	—	14	10
	400	.159	.197	.219	—	—	10	—	13	—	15	10
7 (A,B,C)	500	.253	.301	.342	—	—	15	—	17	11	22	13
	140	.004	.016	.019	—	—	—	—	—	—	—	10
	200	.013	.028	.038	—	—	—	—	—	—	—	10
	400	.062	.096	.126	—	—	—	—	—	—	14	10
	600	.147	.213	.272	—	—	15	—	18	13	22	17
8 (B,C,D)	700	.187	.272	.336	—	—	16	11	18	15	24	18
	185	.010	.018	.022	—	—	—	—	—	—	—	—
	400	.035	.068	.089	—	—	—	—	—	—	10	—
	600	.071	.140	.185	—	—	—	—	10	—	15	10
	800	.130	.233	.294	—	—	11	—	14	10	18	15
10 (C,D)	1000	.199	.358	.449	10	—	16	11	20	14	24	20
	300	.004	.023	.044	—	—	—	—	—	—	—	—
	500	.008	.055	.104	—	—	—	—	—	—	14	—
	800	.020	.125	.180	—	—	—	—	12	10	19	15
	1200	.042	.247	.433	—	—	15	11	17	17	24	23
10 (E)	1500	.066	.381	.647	—	—	22	17	23	19	28	26
	300	.016	.023	.037	—	—	—	—	—	—	10	—
	500	.029	.051	.080	—	—	—	—	—	—	12	—
	800	.067	.119	.180	—	—	—	—	—	—	14	15
	1200	.141	.248	.360	—	—	14	—	17	14	21	20
12 (E,F)	1500	.218	.382	.553	—	—	18	14	22	18	27	24
	430	.017	.037	.056	—	—	—	—	—	—	11	—
	800	.038	.088	.151	—	—	—	—	—	—	13	14
	1200	.076	.181	.306	—	—	11	—	12	10	18	19
	1800	.155	.360	.636	—	—	20	13	23	17	26	22
14 (E,F)	2300	.247	.559	.984	14	—	24	17	30	22	33	27
	600	.004	.022	.040	—	—	—	—	—	—	13	—
	1000	.006	.048	.081	—	—	—	—	12	—	16	14
	1600	.008	.110	.182	—	—	15	—	19	14	24	21
	2400	.011	.237	.391	—	—	26	17	30	22	33	27
16 (F)	3100	.016	.364	.599	15	—	31	22	35	26	40	32
	780	.001	.031	.048	—	—	—	—	14	—	14	11
	1600	.003	.104	.165	—	—	12	—	17	14	23	22
	2400	.006	.232	.356	—	—	22	14	24	19	31	30
	3600	.012	.447	.689	13	—	30	22	33	26	39	33
4200	.019	.572	.893	17	—	32	24	36	30	41	36	

- NOTES:** 1. ΔPs static pressure difference from inlet to discharge.
 2. ΔPs is the minimum required to deliver CFM shown the primary damper in open position.
 3. ΔP does not include hot water or electric coils.
 4. Dash (—) indicates NC level less than 10.

NC level are derived from tests conducted in accordance with AHRI Standard 880-2008 and are calculated in accordance with Appendix E of AHRI Standard 885-2008 as application data based on the following:

Discharge NC levels are based on -

- a) 5 foot rectangular duct lined with 1" fiberglass insulation.
- b) 5 foot lined flex duct (8" diameter).
- c) Flow division.
- d) Space effect factor (2400 ft³) at 5 feet from outlet.
- e) End reflection.
- f) Environment adjustment factor.

Radiated NC levels are based on -

- a) Plenum/ceiling effect - mineral fiber tile
- b) Environment adjustment factor.

NC is not part of the AHRI 880 Certification Program.

DISCHARGE AND RADIATED SOUND DATA
(FAN ON -100% Secondary Air)

Model AS_H

Fan Size	Inlet Size	ESP	CFM	Discharge Sound							Max. NC	Radiated Sound							Max. NC
				Sound Power db								Sound Power db							
				Octave Band								Octave Band							
				2	3	4	5	6	7		2	3	4	5	6	7			
A	5,6,7	.25	100	40	33	24	23	23	22	—	55	45	42	38	28	24	15		
		.25	200	39	40	34	32	24	22	—	59	48	45	42	35	29	20		
		.25	300	49	49	41	41	36	32	—	62	52	48	45	39	36	24		
B	6,7,8	.25	145	39	36	26	24	21	20	—	58	48	44	41	33	26	19		
		.25	270	45	45	39	37	31	26	—	61	51	48	44	38	33	23		
		.25	430	57	58	50	49	45	43	15	69	61	54	52	48	46	33		
C	7,8,10	.25	320	48	47	41	40	35	31	—	62	53	48	45	39	36	24		
		.25	480	60	59	51	50	47	45	16	70	63	56	53	50	48	35		
		.25	600	66	66	56	57	53	51	24	75	68	59	58	54	53	41		
D	8,10	.25	600	57	55	50	48	44	41	11	62	57	55	52	43	39	30		
		.25	800	61	59	55	53	49	48	15	67	62	60	57	49	47	35		
		.25	1000	66	65	60	59	56	56	22	73	68	65	63	54	54	40		
E	10,12,14	.25	1000	58	55	54	52	47	46	10	69	61	56	52	52	48	33		
		.25	1300	63	59	59	56	52	53	17	74	67	59	56	57	54	40		
		.25	1530	68	64	61	61	57	57	21	77	70	63	59	61	58	44		
F	12,14,16	.25	1100	59	55	54	52	48	46	10	69	63	57	53	51	47	33		
		.25	1600	67	64	62	60	56	56	21	75	71	65	61	59	58	42		
		.25	2100	72	68	65	65	61	61	25	80	76	69	66	65	64	48		

- NOTES:** 1. ΔP_s static pressure difference from inlet to discharge.
 2. ΔP_s is the minimum required to deliver CFM shown the primary damper in open position.
 3. ΔP does not include hot water or electric coils.
 4. Dash (—) indicates NC level less than 10.

NC level are derived from tests conducted in accordance with AHRI Standard 880-2008 and are calculated in accordance with Appendix E of AHRI Standard 885-2008 as application data based on the following:

Discharge NC levels are based on -

- a) 5 foot rectangular duct lined with 1" fiberglass insulation.
- b) 5 foot lined flex duct (8" diameter).
- c) Flow division.
- d) Space effect factor (2400 ft³) at 5 feet from outlet.
- e) End reflection.
- f) Environment adjustment factor.

Radiated NC levels are based on -

- a) Plenum/ceiling effect - mineral fiber tile
- b) Environment adjustment factor.

NC is not part of the AHRI 880 Certification Program.

DISCHARGE SOUND DATA (Fan Off -100% Primary Air)

Model AS_H

Inlet (Fan) Size	CFM	Δ Ps	Minimum Δ Ps							1.0" Δ Ps							1.5" Δ Ps							3.0" Δ Ps						
			Sound Power (db) Octave Band							Sound Power (db) Octave Band							Sound Power (db) Octave Band							Sound Power (db) Octave Band						
			2	3	4	5	6	7	2	3	4	5	6	7	2	3	4	5	6	7	2	3	4	5	6	7				
5 (A)	75	0.017	36	27	19	19	22	23	40	33	33	28	29	29	41	36	35	31	34	33	41	39	39	37	42	42				
	100	0.028	36	29	19	19	22	23	42	36	35	28	30	30	44	39	38	33	35	34	45	41	41	38	43	41				
	200	0.115	44	36	32	23	23	24	53	45	42	35	32	30	55	47	44	37	36	35	57	50	47	43	43	43				
	300	0.248	54	46	41	32	30	26	61	52	48	39	35	31	62	54	51	42	38	35	63	57	53	46	45	43				
	350	0.346	58	51	44	36	34	29	63	54	51	41	37	32	63	57	53	44	40	36	65	59	56	48	46	44				
6 (A,B)	110	0.011	34	26	19	19	21	23	41	35	36	32	30	29	43	38	38	35	35	33	44	41	41	39	44	42				
	200	0.045	39	30	23	19	21	23	48	42	40	35	32	31	51	44	43	39	37	36	53	49	46	44	44	43				
	300	0.091	46	38	33	24	23	23	54	47	43	37	33	31	57	50	45	41	37	36	60	54	50	46	44	44				
	400	0.159	52	45	40	32	29	25	60	53	48	40	35	32	62	54	50	43	39	37	64	58	53	48	45	44				
	500	0.253	59	52	46	38	36	30	64	57	51	43	38	34	65	59	54	46	41	38	69	62	57	50	47	45				
7 (A,B,C)	140	0.004	35	26	18	18	21	23	42	38	38	34	32	30	45	41	40	38	37	34	48	45	43	42	44	43				
	200	0.013	35	28	19	19	23	23	47	42	42	38	35	33	49	45	44	41	38	36	51	48	47	46	46	44				
	400	0.062	44	38	32	24	25	24	57	51	46	41	36	33	59	53	49	44	41	37	63	56	54	50	46	45				
	600	0.147	58	49	43	36	35	28	64	58	51	44	40	36	66	60	54	48	42	39	69	64	59	54	48	46				
	700	0.187	61	53	47	40	39	31	66	60	54	46	41	36	68	62	56	49	44	40	73	66	61	55	49	47				
8 (B,C,D)	185	0.010	36	24	22	21	22	23	42	43	43	37	30	32	48	44	46	41	35	34	47	47	48	48	43	43				
	400	0.035	41	30	24	21	22	23	50	46	43	38	34	33	52	50	48	43	37	37	56	54	55	51	44	44				
	600	0.071	47	40	35	29	26	24	58	51	46	41	37	34	59	54	50	45	40	38	62	58	56	53	45	45				
	800	0.130	55	48	42	37	34	28	63	56	50	44	39	35	64	58	53	47	42	39	68	62	58	54	47	46				
	1000	0.199	62	55	49	43	41	34	66	60	54	47	42	37	70	63	56	50	45	41	72	67	61	56	50	47				
10 (C,D)	300	0.004	34	23	19	18	21	23	48	47	44	40	34	32	51	48	47	44	37	36	54	52	50	48	44	43				
	500	0.008	35	27	22	20	22	23	53	49	45	41	35	33	56	53	50	46	39	38	60	57	56	54	47	46				
	800	0.020	40	36	30	24	23	23	59	52	48	43	38	35	62	57	52	47	41	39	67	63	59	56	49	47				
	1200	0.042	52	46	41	35	31	26	66	59	52	47	42	37	67	61	55	50	45	42	73	67	62	57	51	48				
	1500	0.066	60	54	47	41	38	31	70	65	57	50	46	40	72	66	59	52	48	43	75	70	64	58	53	50				
10 (E)	300	0.016	34	23	18	19	20	22	43	42	42	39	37	33	43	42	44	43	42	38	48	46	47	46	48	46				
	500	0.029	38	27	21	21	22	22	49	46	43	39	37	34	50	48	48	44	42	39	54	51	53	50	50	48				
	800	0.067	45	36	30	24	22	22	56	49	45	41	39	35	59	52	49	44	43	41	61	57	56	51	51	50				
	1200	0.141	53	46	40	35	34	30	64	58	50	43	41	37	67	59	53	46	45	42	69	64	59	53	51	50				
	1500	0.218	60	53	46	41	41	38	68	62	54	47	45	40	71	65	56	50	48	44	75	68	61	54	53	52				
12 (E,F)	430	0.017	32	27	20	20	21	21	50	47	47	42	36	36	51	47	50	45	41	39	53	49	51	49	47	47				
	800	0.038	38	31	26	32	28	23	55	49	48	41	38	36	57	52	52	47	43	40	60	55	59	54	51	49				
	1200	0.076	46	39	33	31	28	23	63	54	49	42	40	36	63	57	54	47	44	40	67	62	62	56	52	49				
	1800	0.155	58	49	43	39	38	31	70	63	54	47	45	40	72	64	57	50	47	43	74	68	63	56	53	50				
	2300	0.247	65	57	50	46	45	39	73	67	58	51	49	44	77	70	62	54	52	48	79	74	66	59	56	53				
14 (E,F)	600	0.004	44	31	23	21	22	24	54	51	52	46	39	36	57	51	55	50	44	42	62	54	55	53	49	49				
	1000	0.006	47	37	25	21	22	24	59	53	54	46	41	36	62	57	59	52	46	43	64	58	64	60	54	52				
	1600	0.008	49	41	35	27	25	25	66	58	55	47	43	39	69	61	59	51	47	43	73	67	69	71	55	52				
	2400	0.011	58	50	44	39	35	30	74	66	60	52	48	44	77	69	63	55	51	47	80	73	69	62	57	53				
	3100	0.016	66	58	52	45	42	36	78	71	63	55	51	46	81	74	67	59	54	50	85	79	72	65	60	56				
16 (F)	780	0.001	42	32	25	27	27	26	56	52	53	46	40	40	60	58	57	50	45	43	65	58	58	55	51	50				
	1600	0.003	50	41	32	27	26	25	63	57	55	47	43	41	67	60	60	52	47	45	72	66	68	62	55	52				
	2400	0.006	52	45	39	33	29	26	71	63	57	50	47	43	73	66	62	54	50	47	78	70	69	63	62	54				
	3600	0.012	64	56	50	44	40	33	77	69	63	56	52	48	80	73	66	59	55	51	84	78	72	65	60	56				
	4200	0.019	67	61	54	48	45	39	79	73	65	58	55	50	82	76	68	61	57	53	86	81	73	66	62	58				

- NOTES:** 1. Based on tests conducted in accordance with AHRI Standard 880-2008.
 2. ΔPs is static pressure different from inlet to discharge.
 3. ΔPs is the minimum pressure required to deliver CFM shown with primary damper in wide open position.
 4. ΔPs does not include hot water or electric coils.



A Participating Member in the AHRI 880 Certification Program

Fan Powered Units

RADIATED SOUND DATA (Fan Off -100% Primary Air)

Model AS_H

Inlet (Fan) Size	CFM	Δ Ps	Minimum Δ Ps							1.0" Δ Ps							1.5" Δ Ps							3.0" Δ Ps						
			Sound Power (db) Octave Band							Sound Power (db) Octave Band							Sound Power (db) Octave Band							Sound Power (db) Octave Band						
			2	3	4	5	6	7	2	3	4	5	6	7	2	3	4	5	6	7	2	3	4	5	6	7				
5 (A)	75	0.017	41	31	20	19	22	24	44	32	31	25	27	29	44	33	32	31	33	34	44	34	36	39	43	44				
	100	0.028	41	29	20	19	22	24	45	33	31	25	27	29	45	35	34	32	33	34	45	37	37	39	43	44				
	200	0.115	45	32	25	19	22	25	53	43	36	28	29	29	53	43	38	33	34	34	54	47	42	40	43	44				
	300	0.248	53	44	35	25	24	25	59	49	42	33	32	31	60	49	44	36	37	37	60	52	46	41	44	45				
	350	0.346	57	44	39	31	28	25	62	50	44	34	33	32	62	52	47	37	38	38	63	54	49	41	44	46				
6 (A,B)	110	0.011	38	26	19	18	21	24	42	35	32	26	27	28	43	38	34	32	34	36	41	39	38	39	42	45				
	200	0.045	41	29	21	18	21	24	52	44	37	31	30	31	55	46	40	35	35	37	55	50	45	41	44	46				
	300	0.091	44	32	27	21	22	24	53	44	37	31	31	31	54	47	40	35	35	36	55	51	45	41	43	46				
	400	0.159	52	40	33	26	24	25	57	47	40	33	32	32	59	49	42	36	36	38	60	54	47	42	44	46				
	500	0.253	57	46	38	32	29	26	61	51	43	36	35	33	63	53	45	39	39	39	64	57	49	43	45	47				
7 (A,B,C)	140	0.004	39	26	21	18	21	24	44	36	33	29	29	29	45	39	35	33	35	36	50	43	39	40	43	46				
	200	0.013	41	27	21	18	21	24	47	39	35	29	29	29	48	42	38	34	35	36	48	47	43	40	43	46				
	400	0.062	43	32	25	20	22	24	54	45	39	32	31	32	57	49	42	36	37	38	58	54	48	43	44	46				
	600	0.147	55	43	37	30	29	25	61	51	44	37	36	35	64	54	47	39	39	39	67	60	51	45	45	47				
	700	0.187	58	47	40	33	33	26	63	53	46	38	38	38	66	56	49	41	41	40	68	62	53	46	46	47				
8 (B,C,D)	185	0.010	39	29	20	19	22	24	44	39	40	30	29	28	44	39	41	35	34	33	45	43	44	41	43	44				
	400	0.035	41	30	23	19	22	24	51	43	39	32	30	29	53	47	44	37	35	34	56	51	51	45	44	45				
	600	0.071	45	34	29	23	24	24	56	46	41	34	33	31	58	49	45	39	37	36	62	55	52	46	44	45				
	800	0.130	52	41	37	31	31	25	60	50	44	37	36	32	62	53	47	40	39	37	66	57	53	47	45	46				
	1000	0.199	58	47	42	36	37	29	63	53	47	40	39	35	65	55	50	42	42	39	70	61	55	48	47	47				
10 (C,D)	300	0.004	39	29	21	18	21	24	47	42	38	34	30	28	48	44	41	38	34	34	53	46	45	43	43	45				
	500	0.008	39	31	21	20	22	25	54	45	40	36	31	29	56	49	45	40	36	34	59	54	50	48	44	45				
	800	0.020	45	33	26	22	23	25	59	48	43	38	33	31	62	52	47	42	38	36	65	59	53	50	45	45				
	1200	0.042	51	40	35	31	29	25	63	54	46	41	37	33	67	56	49	45	40	38	72	63	56	51	47	46				
	1500	0.066	57	46	41	37	37	29	67	56	49	44	41	36	69	59	52	47	43	40	74	66	58	53	48	47				
10 (E)	300	0.016	40	36	25	23	23	24	44	41	39	35	31	28	45	42	40	38	36	34	50	47	44	43	44	44				
	500	0.029	42	36	26	24	23	24	50	45	42	37	32	29	53	48	46	40	36	35	58	53	49	46	45	44				
	800	0.067	42	38	28	24	23	24	56	47	41	37	33	30	60	52	45	41	37	36	64	59	52	48	45	45				
	1200	0.141	50	41	37	30	31	25	61	51	44	40	36	32	65	55	48	43	40	37	70	63	55	50	46	46				
	1500	0.218	56	47	41	37	37	29	65	55	48	43	41	35	68	58	50	45	43	39	73	65	57	51	48	46				
12 (E,F)	430	0.017	39	38	33	26	23	23	45	46	42	38	31	29	48	46	44	41	36	34	52	51	47	45	44	44				
	800	0.038	41	38	31	26	23	23	53	47	43	39	33	29	54	52	47	44	38	34	60	58	53	51	46	44				
	1200	0.076	41	40	32	28	25	24	59	51	43	40	34	30	62	54	48	45	39	36	66	63	56	53	47	44				
	1800	0.155	51	44	37	36	33	25	64	56	47	43	39	34	67	59	51	47	42	37	71	65	58	53	48	45				
	2300	0.247	58	50	44	42	40	30	67	60	49	46	43	36	71	63	53	49	45	40	75	69	59	55	50	46				
14 (E,F)	600	0.004	44	37	25	23	22	23	53	48	44	38	31	29	54	49	46	42	36	33	59	53	50	46	44	44				
	1000	0.006	44	37	29	25	23	23	55	49	46	39	32	30	59	54	51	44	37	34	62	58	55	51	45	44				
	1600	0.008	45	37	30	26	23	24	61	51	46	39	33	31	65	56	50	44	38	36	69	64	59	53	46	45				
	2400	0.011	53	43	39	34	31	26	67	57	49	43	37	33	71	60	53	46	41	39	75	67	60	54	47	46				
	3100	0.016	59	49	45	40	39	33	71	60	53	46	42	38	74	63	56	49	44	41	79	70	62	55	49	47				
16 (F)	780	0.001	41	37	26	24	24	25	55	48	46	39	35	34	57	50	49	43	40	39	62	55	52	48	47	47				
	1600	0.003	41	37	26	24	24	25	60	50	46	40	36	34	65	54	51	45	40	38	71	62	59	55	49	47				
	2400	0.006	47	40	35	28	27	25	65	54	49	42	38	35	69	58	53	47	43	40	77	65	61	55	50	48				
	3600	0.012	56	46	43	38	36	30	71	59	53	47	43	39	74	62	56	49	45	42	80	69	62	55	51	49				
	4200	0.019	60	51	47	42	41	35	73	62	55	49	46	41	77	65	58	51	47	44	82	70	63	56	52	49				

- NOTES:** 1. Based on tests conducted in accordance with AHRI Standard 880-2008.
 2. ΔPs is static pressure different from inlet to discharge.
 3. ΔPs is the minimum pressure required to deliver CFM shown with primary damper in wide open position.
 4. ΔPs does not include hot water or electric coils.



A Participating Member in the AHRI 880 Certification Program

Fan Powered Units

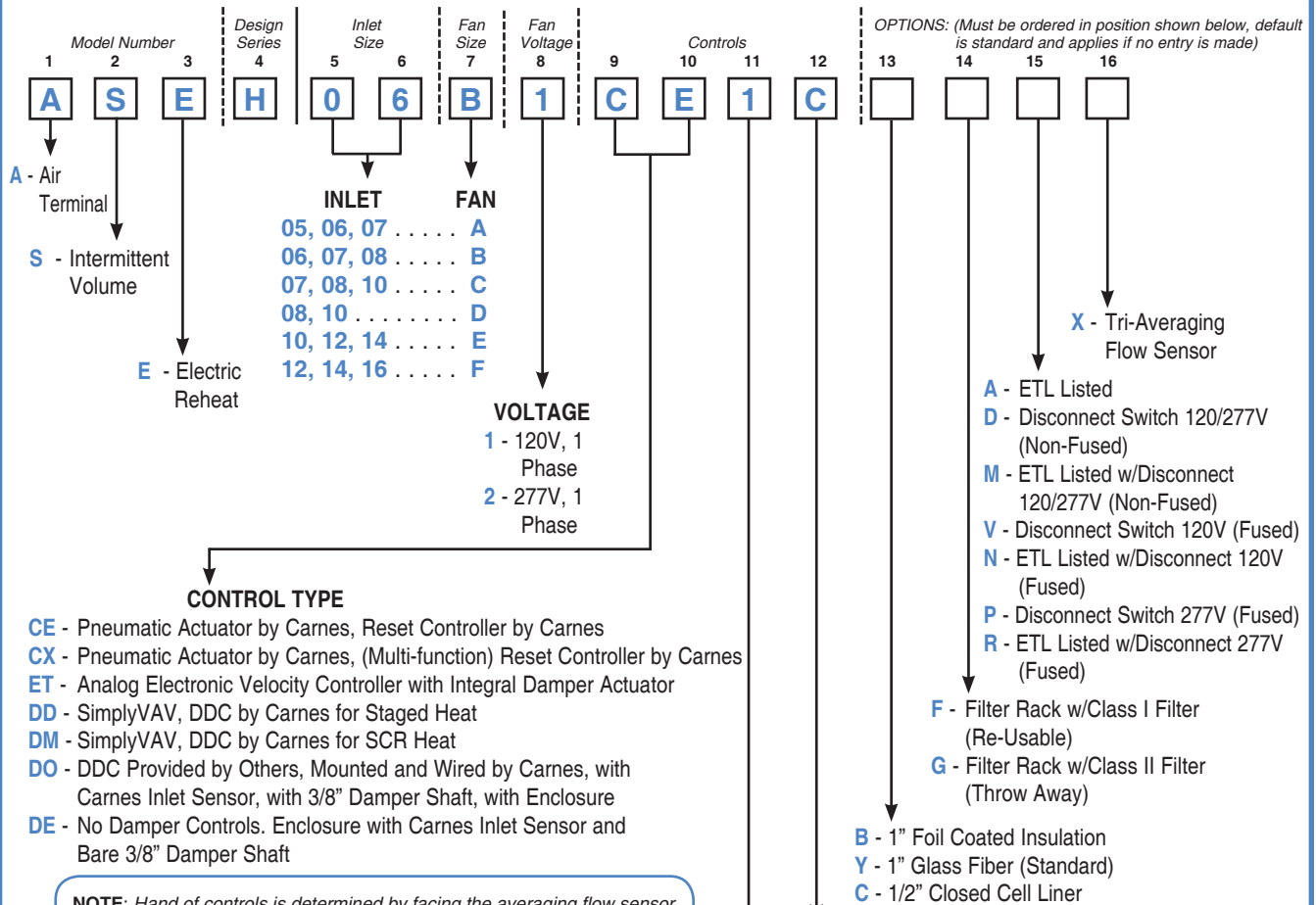

NOTE: Hand of controls is determined by facing the averaging flow sensor (inlet of the unit) with the supply air hitting the back of your head.

▼ **Electronic Thermostat**

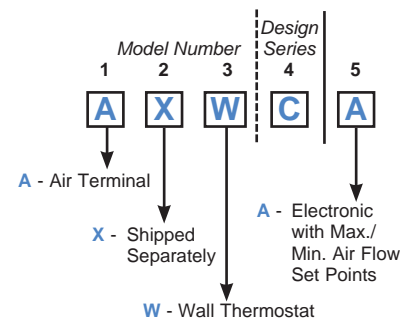

A Carnes Electronic Thermostat **must be ordered** with the ET Electronic Control Option.

▼ **Direct Digital Control (DD/DC/DM)**

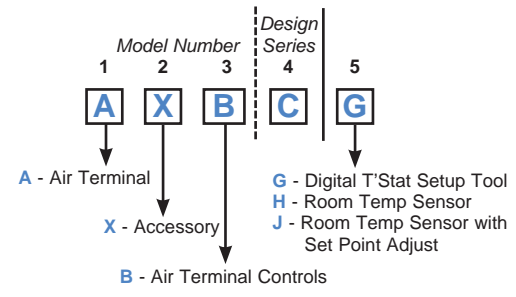

ACTUATOR VENDOR

- C - Carnes OEM
- D - DDC Actuator (DO Option Only)
- N - Not Applicable (DE Option Only)

CONTROLS AND DAMPER ARRANGEMENT

- *1 - Normally Open - Right Hand Controls (Electronic/DO, DE, ET) (All Pneumatic Control Types for Reverse Acting Thermostat)
- *2 - Normally Open - Left Hand Controls (Electronic/DO, DE, ET) (All Pneumatic Control Types for Reverse Acting Thermostat)
- 3 - Normally Closed - Right Hand Controls (All Pneumatic Control Types for Direct Acting Thermostat)
- 4 - Normally Closed - Left Hand Controls (All Pneumatic Control Types for Direct Acting Thermostat)
- 5 - Normally Open - Right Hand Controls (All Pneumatic Control Types for Direct Acting Thermostat)
- 6 - Normally Open - Left Hand Controls (All Pneumatic Control Types for Direct Acting Thermostat)
- 7 - Normally Closed - Right Hand Controls (All Pneumatic Control Types for Reverse Acting Thermostat)
- 8 - Normally Closed - Left Hand Controls (All Pneumatic Control Types for Reverse Acting Thermostat)

* Electronic and DDC Units **DO NOT** fail open. '1' or '2' is used for Right or Left Hand Only. Electronic Units are shipped with the Damper in the Open Position.

Model ASEH

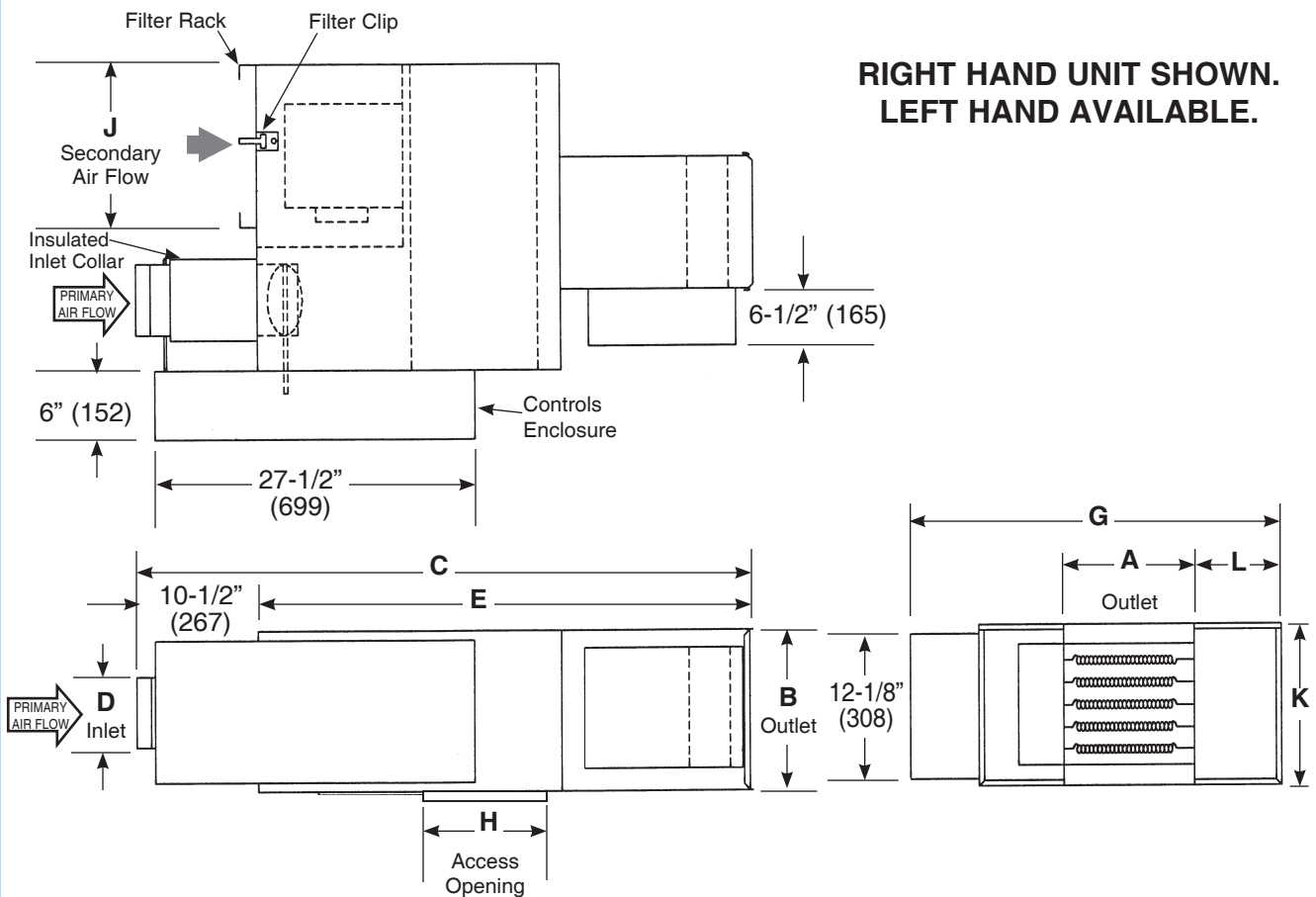

Fan Powered Units

DIMENSIONS LISTED IN INCHES (MILLIMETERS)															
Fan Size	Inlet Size	Primary Nominal CFM(L/s)	Secondary Nominal CFM (L/s) @ .25"E.S.P.	Fan H.P.	Outlet		C	Inlet	E	G	H	J	K	L	
					A	B		D							
A	05	350 (165)	290 (137)	1/6				4-7/8 (124)							
	06	500 (236)						5-7/8 (149)							
	07	700 (330)						6-7/8 (175)							
B	06	500 (236)	400 (189)	1/6	14 (356)	14 (356)	63-3/4 (1619)	5-7/8 (149)	51-1/4 (1302)	35 (889)	10 (254)	15-1/2 (394)	14 (356)	7-1/2 (191)	
	07	700 (330)						6-7/8 (175)							
	08	1000 (472)						7-7/8 (200)							
C	07	700 (330)	570 (269)	1/6				6-7/8 (175)							
	08	1000 (472)						7-7/8 (200)							
	10	1500 (708)						9-7/8 (251)							
D	08	1000 (472)	900 (424)	1/4	14 (356)	14 (356)	69-3/4 (1771)	7-7/8 (200)	57-1/4 (1454)	37 (940)	16 (406)	17-1/2 (445)	14 (356)	8-1/2 (216)	
	10	1500 (708)						9-7/8 (251)							
E	10	1500 (708)	1300 (614)	1/4	16 (406)	17-1/2 (445)	71-3/4 (1822)	9-7/8 (251)	59-1/4 (1505)	50 (1270)	16 (406)	24-1/2 (622)	17-1/2 (446)	14 (356)	
	12	2300 (1086)						11-7/8 (302)						10 (254)	
	14	3100 (1463)						13-7/8 (352)						14 (356)	
F	12	2300 (1086)	1870 (883)	1/2	16 (406)			11-7/8 (302)							
	14	3100 (1463)						13-7/8 (352)							10 (254)
	16	4200 (1982)						15-7/8 (403)							

NOTE: Outlet is designed for slip and drive duct connection.