

Models **ACF w/o Coil**
ACW w/Hot Water Coil
ACE w/Electric Coil

The **Carnes** constant volume fan terminal unit provides constant air volume to the space while retaining the advantages of a variable air volume system.

The primary air control assembly operates in the same manner as a standard throttling control valve when cooling loads are high. As cooling loads diminish the integral blower(s) induces warm ceiling plenum air to maintain constant air volume.

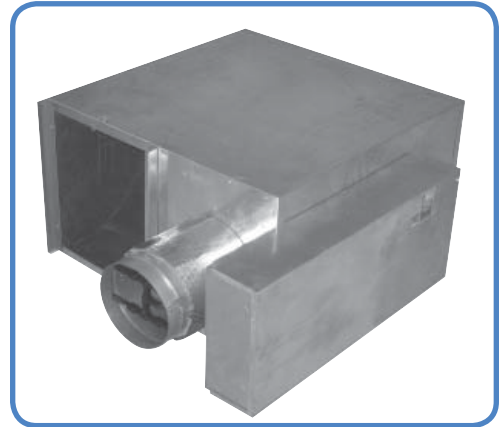

Features Include:

- Air flow capacities to 4130 CFM.
- Durable 22 gauge galvanized steel casing construction.
- Bottom access panel for internal components.
- Flange or slip and drive discharge connections.
- Forward curved centrifugal type fan assemblies with thermally protected, Permanent Split Capacitor or ECM type, fractional horsepower motors. Multiple voltages available.
- Adjustable SCR fan speed control.
- Fan/motor assemblies are isolated from the casing using rubber isolators to minimize vibration transmission.
- Low leakage primary air damper design.
- Secondary air filter rack.
- Performance data based on tests conducted in accordance with AHRI Standard 880-2008.
- Air flow switch.
- All units are equipped with pressure independent pneumatic or electronic controls.
- Field adjustable P/E switch with pneumatic controls.
- Tri-Averaging type velocity sensor and calibration chart for measuring air flow through the primary air damper.
- Insulation is 1" thick, 1-1/2 lb. dual density fiberglass with surface treated to prevent air erosion, UL listed and meets NFPA 90A requirements.
- Damper controls and fan controls are located in one enclosure.
- AHRI listed.
- Optional ETL listing.
- Optional secondary air sound baffle. Sound baffle is factory attached to secondary air inlet.
- Optional one to four row hot water coils (Model ACW). Coil is factory attached to the unit discharge.
- Optional one or two stage electric reheat coils (Model ACE). Coil is factory attached to unit discharge.
- Optional secondary air filters, Class I (re-usable) or Class II (throw away).
- Optional non-fused or fused fan disconnect switch.
- Optional foil coated insulation.
- Optional fiber-free liner.
- Optional dual wall.

Available Modules:

- Basic control unit — **Model ACF.**
- Basic control unit with hot water coil — **Model ACW.**
- Basic control unit with electric coil — **Model ACE.**



IAQ Insulation
Available

FAN CURVES CFM vs EXTERNAL STATIC PRESSURE

Fan Size B — AC 06
1/4 HP ECM Motor

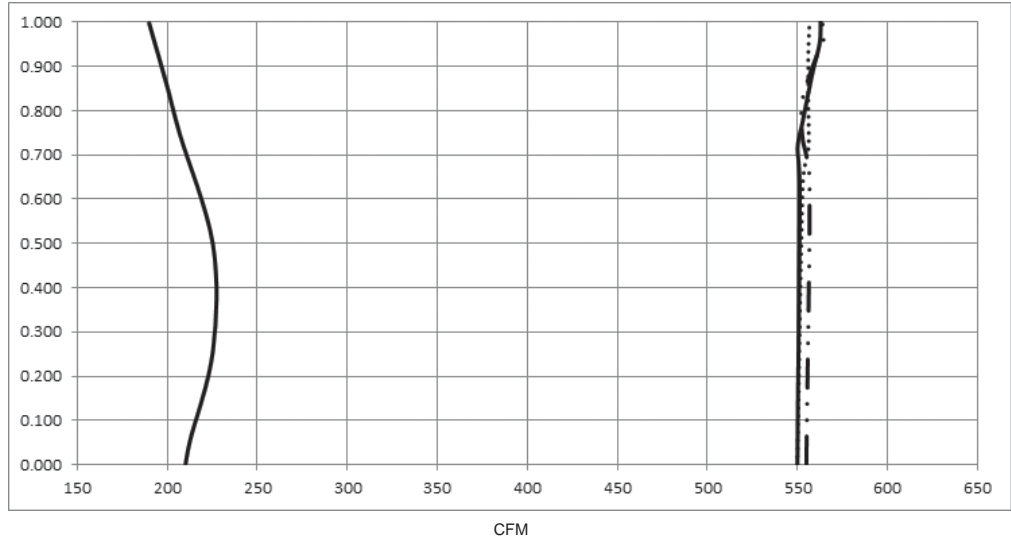
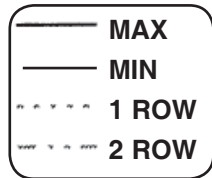

Fan Powered Units

Fan Size C — AC 07
1/3 HP ECM Motor

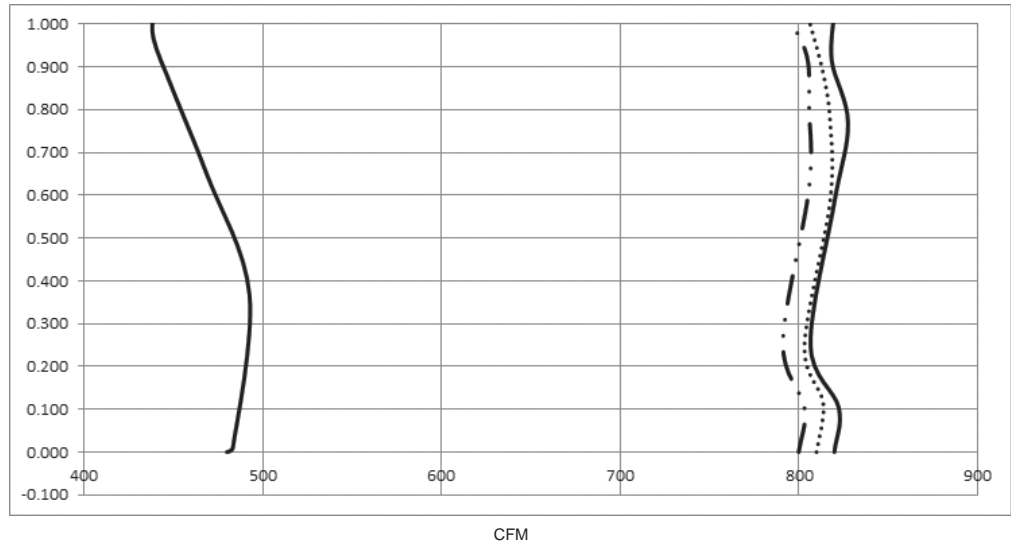
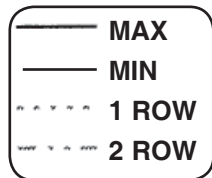

- NOTES:**
1. The ECM is designed to maintain a constant air flow as the static pressure changes.
 2. The ECM maintains the static pressure more accurately when close to the maximum flow for the unit. For this reason selection of a unit at the top of its range is recommended.

FAN CURVES CFM vs EXTERNAL STATIC PRESSURE

Fan Size D — AC 08
1/2 HP ECM Motor

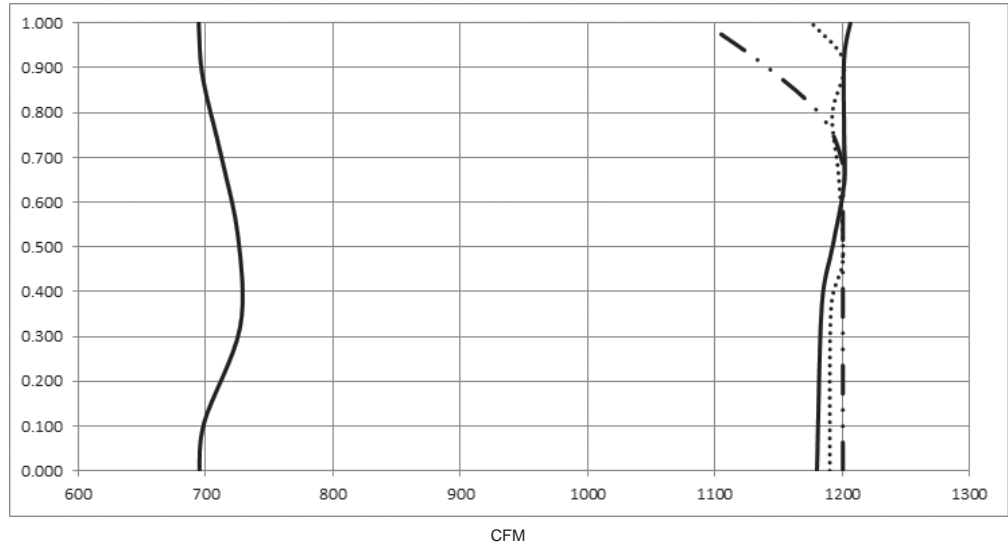
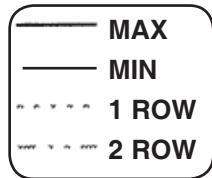

Fan Size E — AC 10
3/4 HP ECM Motor

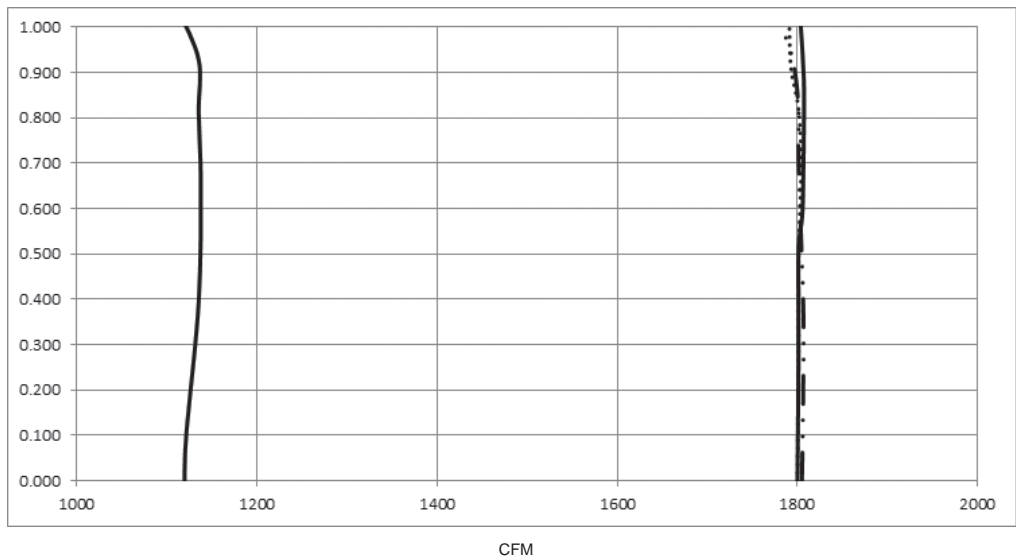
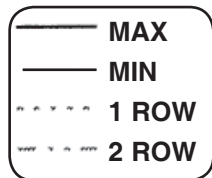

- NOTES:**
1. The ECM is designed to maintain a constant air flow as the static pressure changes.
 2. The ECM maintains the static pressure more accurately when close to the maximum flow for the unit. For this reason selection of a unit at the top of its range is recommended.

FAN CURVES CFM vs EXTERNAL STATIC PRESSURE

Fan Size F — AC 12
1 HP ECM Motor

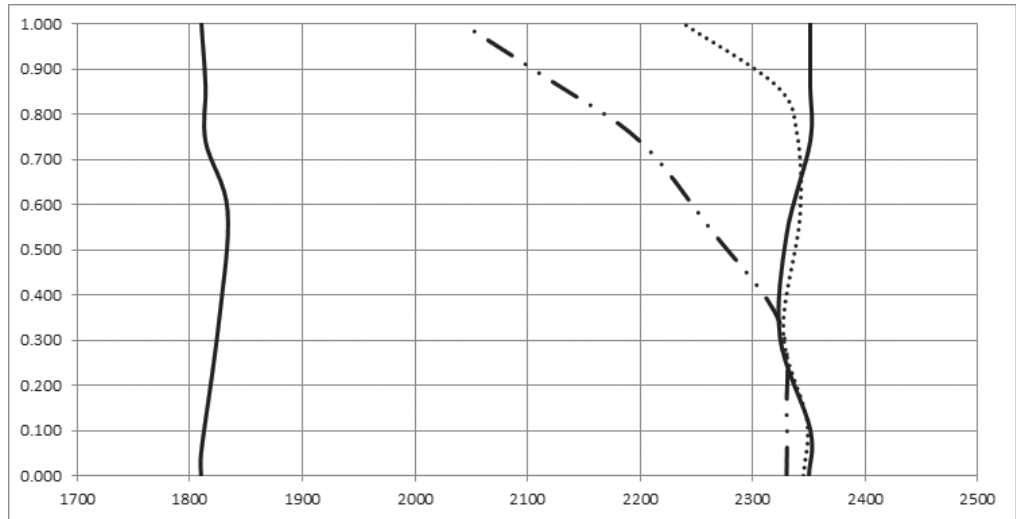
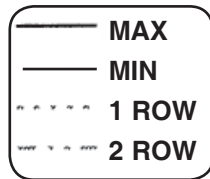

Fan Size H — AC 14
2X 3/4 HP ECM Motor

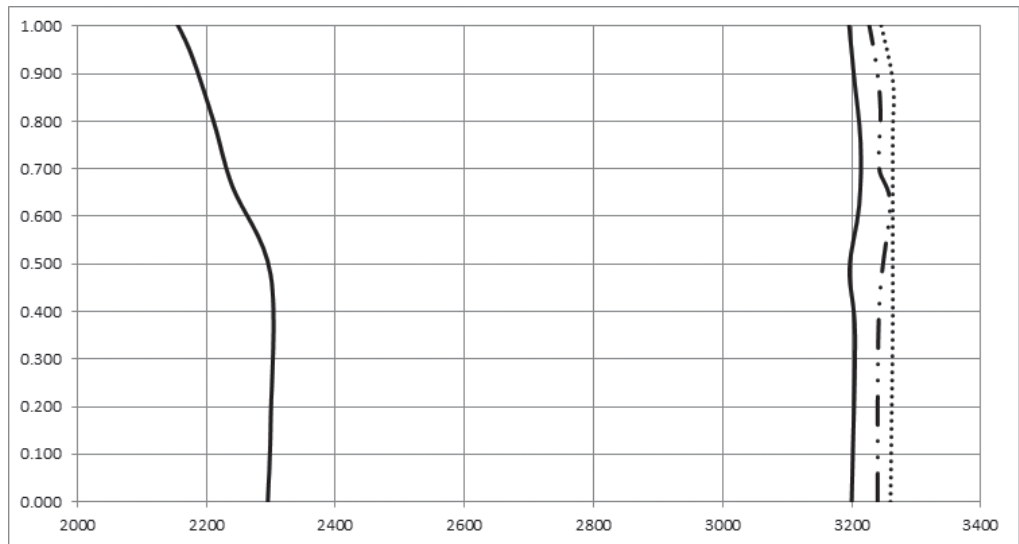
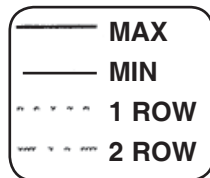

- NOTES:**
1. The ECM is designed to maintain a constant air flow as the static pressure changes.
 2. The ECM maintains the static pressure more accurately when close to the maximum flow for the unit. For this reason selection of a unit at the top of its range is recommended.

Fan Powered Units

FAN CURVES CFM vs EXTERNAL STATIC PRESSURE

Fan Size J — AC 16
(2) 1 HP ECM Motor

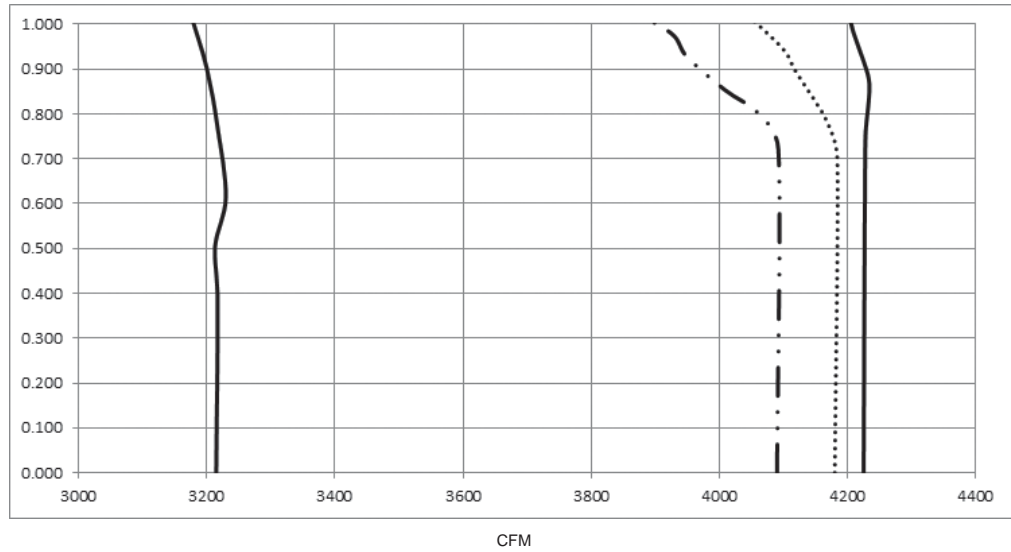
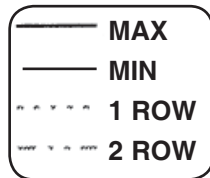

- NOTES:**
1. The ECM is designed to maintain a constant air flow as the static pressure changes.
 2. The ECM maintains the static pressure more accurately when close to the maximum flow for the unit. For this reason selection of a unit at the top of its range is recommended.

Model ACFJ/ACEJ

Fan Power Terminal Units - ECM

Unit Size	Air Flow CFM	Min. ΔP_s in w.g.	Discharge Sound Max. NC					Radiated Sound Max. NC				
			Fan Only	Min. w.g.	1.0" w.g.	1.5" w.g.	3.0" w.g.	Fan Only	Min. w.g.	1.0" w.g.	1.5" w.g.	3.0" w.g.
6 (B)	375	0.267	12	22	22	24	29	35	39	38	41	45
	425	0.343	16	26	25	26	32	34	44	42	45	44
	480	0.425	18	31	28	29	34	37	43	43	44	48
	550	0.575	23	37	33	34	36	38	49	53	50	53
7 (C)	650	0.364	33	47	43	45	45	49	50	52	53	58
	700	0.439	36	43	44	44	42	51	55	57	54	56
	750	0.472	38	43	45	43	45	53	57	58	56	59
	800	0.525	41	41	42	40	44	54	58	60	60	60
8 (D)	950	0.350	31	37	39	39	41	40	48	50	51	53
	1050	0.420	31	40	41	43	44	40	49	54	56	57
	1100	0.449	32	42	44	45	45	43	51	52	55	55
	1200	0.525	34	44	46	46	47	44	54	56	57	60
10 (E)	1450	0.246	33	35	37	37	41	42	48	49	52	59
	1550	0.277	33	37	37	39	42	44	49	52	55	58
	1650	0.297	34	39	38	40	43	45	49	52	55	61
	1800	0.362	36	40	40	42	44	47	51	55	56	60
12 (F)	2125	0.261	43	41	44	45	48	52	55	57	58	64
	2200	0.288	43	42	44	45	50	51	56	57	58	63
	2275	0.301	42	44	45	47	49	51	56	58	58	64
	2350	0.309	43	44	46	47	51	54	56	58	59	63
14 (H)	2800	0.273	32	33	46	49	54	47	49	58	59	63
	2900	0.288	33	34	45	49	54	49	50	58	63	66
	3000	0.291	34	35	46	49	54	51	52	60	62	70
	3200	0.335	36	37	47	50	56	51	50	63	64	65
16 (J)	3750	0.329	39	41	51	53	57	56	58	66	66	71
	3900	0.348	42	42	51	54	58	60	60	68	68	72
	4050	0.418	43	44	52	54	59	64	56	65	69	73
	4200	0.414	45	45	53	55	59	59	59	65	69	71

- NOTES:**
1. ΔP_s static pressure difference from inlet to discharge.
 2. The lowest value of ΔP_s is the minimum pressure required to deliver CFM shown with primary damper in wide open position.
 3. ΔP_s does not include hot water or electric coils.
 4. (—) indicates NC levels less than 10.

NC Levels are derived from tests conducted in accordance with AHRI Standard 880-2008 and are calculated in accordance with AHRI Standard 885-2008 as application data based on the following:

Discharge NC levels are based on —

- a) 5 foot rectangular duct lined with 1" fiberglass insulation.
- b) 5 foot lined flex duct (8" diameter).
- c) Flow division.
- d) Space effect factor (2400ft₃) at 5 feet from outlet.
- e) End reflection.
- f) Environmental adjustment factor.

Radiated NC levels are based on —

- a) Plenum/ceiling effect - 5/8" mineral fiber tile, 35 lb/ft₃ - 3 foot plenum
- b) Environmental adjustment factor.

NC is not part of the AHRI 880 Certified Program.

Sound Data (Sound Power by Octave Band)

Discharge Sound Power

Model ACFJ/ACEJ

Fan Power Terminal Units - ECM

Inlet (Fan) Size	Air Flow CFM	Fan Only Octave Band							Primary Air							Primary Air							Primary Air							Primary Air						
									P _s (0.5 w.g.) Octave Band							P _s (1.0 w.g.) Octave Band							P _s (1.5 w.g.) Octave Band							P _s (3.0 w.g.) Octave Band						
		2	3	4	5	6	7	2	3	4	5	6	7	2	3	4	5	6	7	2	3	4	5	6	7	2	3	4	5	6	7					
6 (B)	375	61	57	54	48	49	48	69	58	54	52	48	43	69	58	54	52	47	38	70	59	55	51	46	38	74	63	58	55	51	45					
	425	64	54	51	48	44	39	72	61	57	55	52	48	71	60	56	55	51	44	72	61	57	55	51	44	76	65	60	57	54	49					
	480	66	57	53	51	47	43	76	64	60	58	56	52	74	63	58	56	54	48	74	64	59	57	54	49	78	67	62	59	56	51					
	550	70	59	56	54	51	48	81	68	63	61	59	56	77	66	61	59	58	53	78	66	61	59	58	54	79	68	63	60	58	54					
7 (C)	650	78	73	79	67	69	64	84	73	68	67	65	63	84	73	68	66	65	64	83	73	69	67	66	65	86	75	70	68	67	66					
	700	82	72	68	67	66	66	85	75	70	68	66	65	87	75	69	68	66	65	85	75	70	68	67	66	87	77	71	69	68	67					
	750	83	74	69	69	67	67	87	77	71	69	68	67	88	77	72	69	68	67	87	77	72	70	69	68	87	78	74	71	70	69					
	800	85	75	69	71	69	68	90	79	72	71	69	68	87	77	71	70	69	68	89	78	72	70	69	67	89	79	73	71	70	69					
8 (D)	950	78	74	72	64	66	62	82	72	70	71	69	67	84	73	70	69	68	66	84	74	70	70	68	66	85	76	71	70	68	66					
	1050	78	68	67	66	65	63	85	74	72	73	71	69	86	75	71	71	69	68	87	77	73	72	70	69	88	78	73	72	70	69					
	1100	78	69	67	67	65	63	86	75	73	73	72	70	88	78	73	73	72	70	89	78	74	73	71	70	89	78	74	73	71	70					
	1200	80	70	68	68	67	65	88	77	75	75	74	73	89	79	75	74	73	72	89	79	75	74	73	72	89	79	75	74	73	72					
10 (E)	1450	79	72	70	66	67	67	81	74	72	72	69	68	82	74	73	73	70	69	83	75	74	74	71	69	86	79	76	76	73	71					
	1550	79	71	72	70	67	66	83	75	73	73	71	70	82	75	74	74	71	69	84	76	75	75	72	70	86	80	77	77	74	72					
	1650	80	72	72	71	69	68	84	76	75	74	72	71	83	76	75	75	72	71	85	77	76	77	73	71	87	81	78	78	75	73					
	1800	82	74	74	73	70	70	85	78	77	76	74	73	85	77	77	77	74	72	86	78	78	78	75	73	88	82	79	80	77	75					
12 (F)	2125	87	81	78	72	74	74	85	80	77	78	76	74	88	81	79	79	76	74	89	82	80	80	77	75	91	85	81	82	79	76					
	2200	87	78	75	77	74	73	86	81	78	79	77	75	88	81	79	80	77	75	89	83	80	81	78	76	92	85	82	83	80	77					
	2275	86	78	76	77	74	73	88	82	79	80	77	76	88	82	80	81	78	76	90	83	81	82	79	77	92	86	82	83	80	78					
	2350	87	79	77	78	75	74	88	82	80	80	78	77	89	82	81	82	79	77	90	84	81	82	79	77	93	86	83	84	81	78					
14 (H)	2800	79	76	76	70	71	70	79	74	72	73	71	69	89	82	78	78	76	75	92	84	79	80	78	77	95	88	82	82	80	79					
	2900	80	74	73	74	71	70	80	75	72	73	72	70	89	82	78	78	77	76	92	84	80	80	78	77	95	89	82	83	81	80					
	3000	80	74	73	74	72	71	80	76	73	74	72	71	89	83	79	79	77	76	92	85	80	80	79	78	96	89	83	83	81	80					
	3200	81	76	75	76	73	72	82	77	74	75	74	72	90	84	80	80	78	77	93	86	81	81	79	78	97	91	84	84	82	81					
16 (J)	3750	84	81	83	78	78	77	85	80	77	79	77	76	93	87	83	84	82	82	95	89	85	85	83	83	98	92	86	87	85	85					
	3900	86	82	79	81	79	78	86	81	78	80	78	77	93	88	84	85	83	82	95	90	86	86	84	84	99	93	87	88	86	86					
	4050	87	83	80	82	80	80	87	82	79	81	79	78	94	89	85	86	84	83	96	91	86	87	85	85	99	94	88	88	87	86					
	4200	89	84	81	83	81	81	89	83	80	82	80	79	95	90	86	86	84	84	96	92	87	88	86	85	100	94	88	89	87	86					

- NOTES:**
1. Based on tests conducted in accordance with AHRI Standard 880-2008.
 2. Δ P_s static pressure difference from inlet to discharge.
 3. Δ P_s is the minimum pressure required to deliver CFM shown with primary damper in wide open position.
 4. Dash (—) indicates db level less than 10.



A Participating Member in the AHRI 880 Certification Program

Fan Powered Units

Sound Data (Sound Power by Octave Band)

Radiated Sound Power

Model ACFJ/ACEJ

Fan Power Terminal Units - ECM

Fan Powered Units

Inlet (Fan) Size	Air Flow CFM	Fan Only Octave Band							Primary Air							Primary Air							Primary Air							Primary Air						
									P _s (0.5 w.g.) Octave Band							P _s (1.0 w.g.) Octave Band							P _s (1.5 w.g.) Octave Band							P _s (3.0 w.g.) Octave Band						
		2	3	4	5	6	7	2	3	4	5	6	7	2	3	4	5	6	7	2	3	4	5	6	7	2	3	4	5	6	7					
6 (B)	375	70	57	50	47	42	43	73	64	57	50	47	45	73	62	57	52	49	47	74	65	59	54	52	50	77	66	63	58	58	56					
	425	69	59	50	47	43	43	77	65	59	53	49	46	75	64	61	54	51	48	78	67	61	55	52	51	77	69	65	59	58	57					
	480	72	60	51	47	43	44	76	67	60	56	51	48	76	67	62	54	52	49	77	66	61	54	50	47	80	71	65	60	58	57					
	550	73	60	53	49	46	46	81	71	64	58	54	51	83	70	62	58	55	54	82	72	65	59	57	55	84	72	67	62	60	58					
7 (C)	650	81	71	58	56	54	53	81	71	62	58	55	54	83	76	64	59	56	55	84	76	64	59	57	55	88	78	68	63	60	59					
	700	82	74	60	56	55	54	85	77	64	60	56	55	87	77	64	59	56	55	84	77	65	60	57	55	86	78	68	64	60	59					
	750	84	73	61	58	55	55	87	77	65	60	56	55	87	77	65	60	57	56	86	77	67	61	58	57	88	81	70	64	61	59					
	800	85	75	62	59	56	56	88	78	66	61	57	57	89	78	67	62	58	57	90	79	67	63	59	57	89	81	70	65	61	60					
8 (D)	950	71	69	57	54	51	49	78	75	63	61	57	56	81	77	64	60	56	55	79	78	65	62	58	57	83	80	68	64	60	59					
	1050	73	69	59	59	53	52	79	76	65	62	59	58	82	80	65	62	58	58	82	82	68	63	59	59	84	83	69	65	62	61					
	1100	74	71	59	57	53	52	82	77	65	63	60	59	82	79	66	63	60	59	83	82	68	63	60	59	84	81	70	66	62	61					
	1200	76	72	60	58	54	53	85	79	67	65	62	61	85	82	68	65	61	61	85	83	70	65	61	61	87	85	72	68	64	63					
10 (E)	1450	75	70	62	58	55	53	80	73	65	62	58	56	81	76	69	64	58	58	82	79	71	65	61	60	89	81	74	69	64	64					
	1550	77	71	63	58	57	55	81	75	66	63	59	57	83	78	70	65	60	58	86	79	71	66	62	60	88	83	75	70	66	65					
	1650	78	72	65	60	58	57	81	76	68	63	60	59	83	78	71	67	62	60	85	81	73	67	63	62	90	84	76	70	66	65					
	1800	79	73	67	63	59	59	83	78	70	66	62	61	86	79	72	67	63	62	86	81	73	68	64	63	89	84	77	72	68	67					
12 (F)	2125	83	76	67	66	62	62	85	79	70	67	63	64	87	81	71	70	64	64	88	82	74	71	65	64	93	87	77	74	69	67					
	2200	82	76	68	68	62	63	87	80	72	68	64	64	87	82	74	69	65	65	88	83	75	71	66	65	92	86	78	75	69	67					
	2275	83	78	68	67	63	63	86	81	72	69	65	65	88	83	72	70	66	66	88	83	74	71	67	66	92	88	78	75	70	68					
	2350	84	77	69	69	64	64	86	82	71	70	66	66	86	84	72	71	67	66	89	83	75	73	68	67	92	88	79	76	71	68					
14 (H)	2800	79	71	66	62	60	58	81	74	68	62	60	58	88	80	73	68	64	62	89	82	74	68	66	64	91	86	79	72	68	66					
	2900	81	73	66	63	61	58	82	75	69	63	61	58	88	81	74	68	65	63	92	83	74	68	66	64	94	86	78	73	69	67					
	3000	82	74	66	63	61	59	83	76	70	63	62	59	89	83	74	68	66	63	91	83	75	69	67	65	97	88	79	73	69	67					
	3200	82	75	67	65	63	60	82	77	72	65	63	60	92	82	76	69	67	65	92	86	77	71	68	66	93	89	81	74	70	68					
16 (J)	3750	86	79	72	69	67	66	88	80	73	68	67	64	94	87	79	72	72	70	94	88	80	73	73	71	98	92	83	76	75	73					
	3900	89	79	72	70	69	66	89	81	74	69	67	65	95	86	79	73	72	71	96	89	80	75	74	72	99	92	82	76	76	74					
	4050	92	81	74	71	69	67	86	82	75	70	69	66	93	88	79	74	73	71	96	91	81	75	75	73	100	93	84	78	77	74					
	4200	89	82	74	71	71	69	88	83	76	70	70	67	94	88	79	74	74	71	96	90	81	76	75	73	98	94	84	78	77	75					

- NOTES:**
1. Based on tests conducted in accordance with AHRI Standard 880-2008.
 2. ΔP_s static pressure difference from inlet to discharge.
 3. ΔP_s is the minimum pressure required to deliver CFM shown with primary damper in wide open position.
 4. Dash (—) indicates db level less than 10.



A Participating Member in the AHRI 880 Certification Program

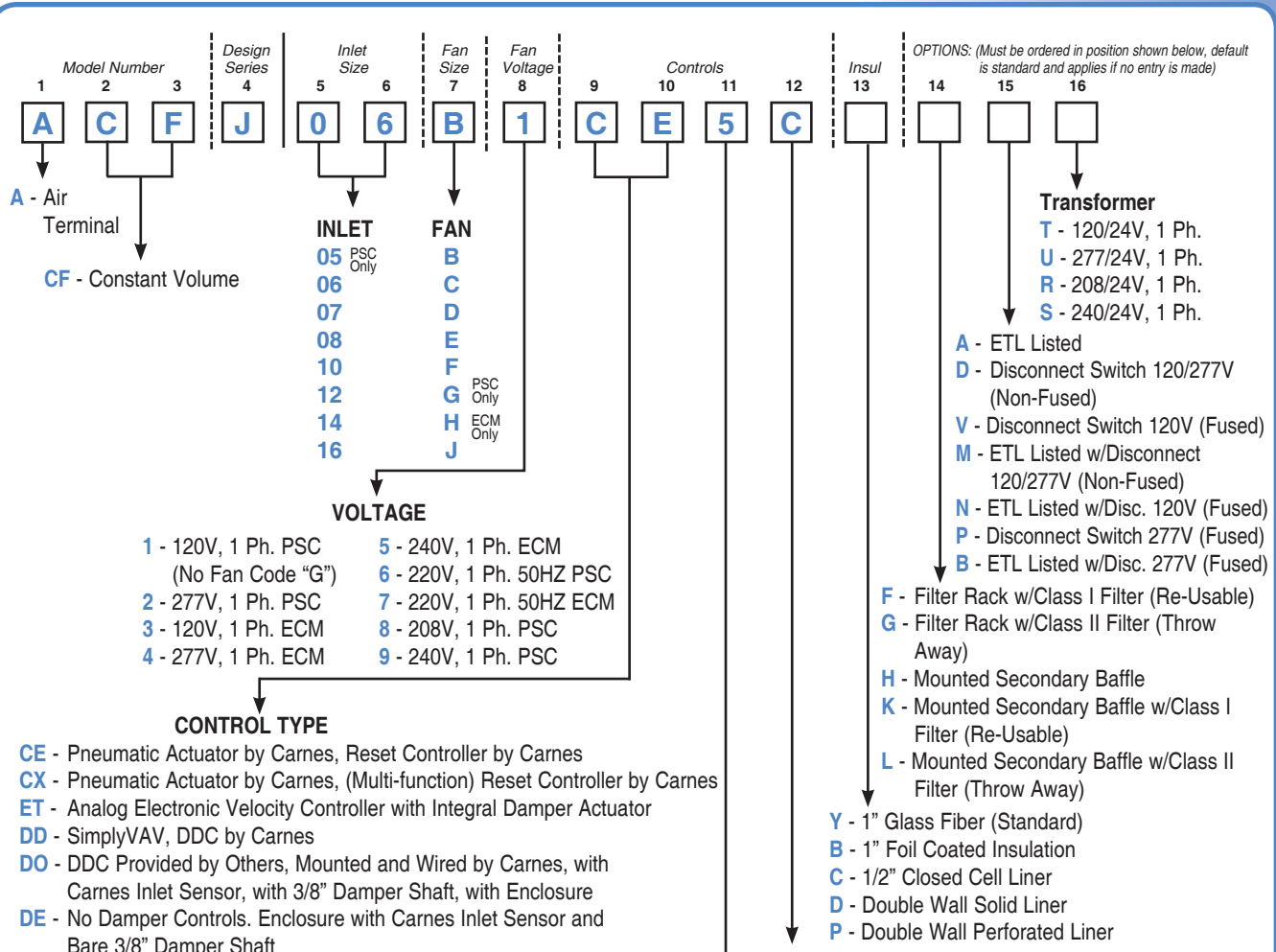

NOTE: Hand of controls is determined by facing the averaging flow sensor (inlet of the unit) with the supply air hitting the back of your head.

▼ Electronic Thermostat

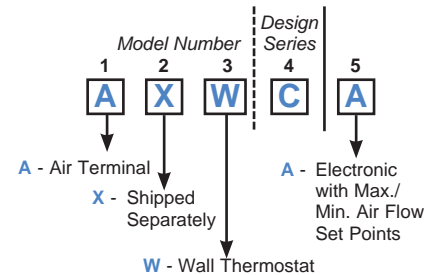

A Carnes Electronic Thermostat **must be ordered** with the ET Electronic Control Option.

▼ Direct Digital Control (DD/DC/DM)

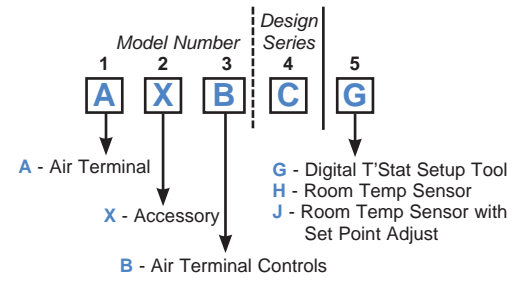

ACTUATOR VENDOR

- C - Carnes OEM
- D - DDC Actuator (DO Option Only)
- N - Not Applicable (DE Option Only)

CONTROLS AND DAMPER ARRANGEMENT

- *1 - Normally Open - Right Hand Controls (Electronic/DO, DE, ET) (All Pneumatic Control Types for Reverse Acting Thermostat)
- *2 - Normally Open - Left Hand Controls (Electronic/DO, DE, ET) (All Pneumatic Control Types for Reverse Acting Thermostat)
- 3 - Normally Closed - Right Hand Controls (All Pneumatic Control Types for Direct Acting Thermostat)
- 4 - Normally Closed - Left Hand Controls (All Pneumatic Control Types for Direct Acting Thermostat)
- 5 - Normally Open - Right Hand Controls (All Pneumatic Control Types for Direct Acting Thermostat)
- 6 - Normally Open - Left Hand Controls (All Pneumatic Control Types for Direct Acting Thermostat)
- 7 - Normally Closed - Right Hand Controls (All Pneumatic Control Types for Reverse Acting Thermostat)
- 8 - Normally Closed - Left Hand Controls (All Pneumatic Control Types for Reverse Acting Thermostat)

* Electronic and DDC Units **DO NOT** fail open. '1' or '2' is used for Right or Left Hand Only. Electric/Electronic Units are shipped with the Damper in the Open Position.

• FAN SIZES B - F — ECM

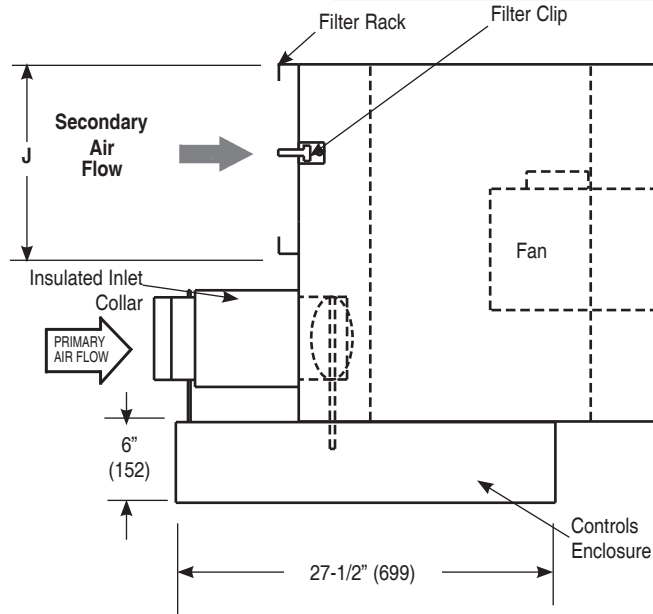

RIGHT HAND PRIMARY AIR UNIT SHOWN.
LEFT HAND AVAILABLE.

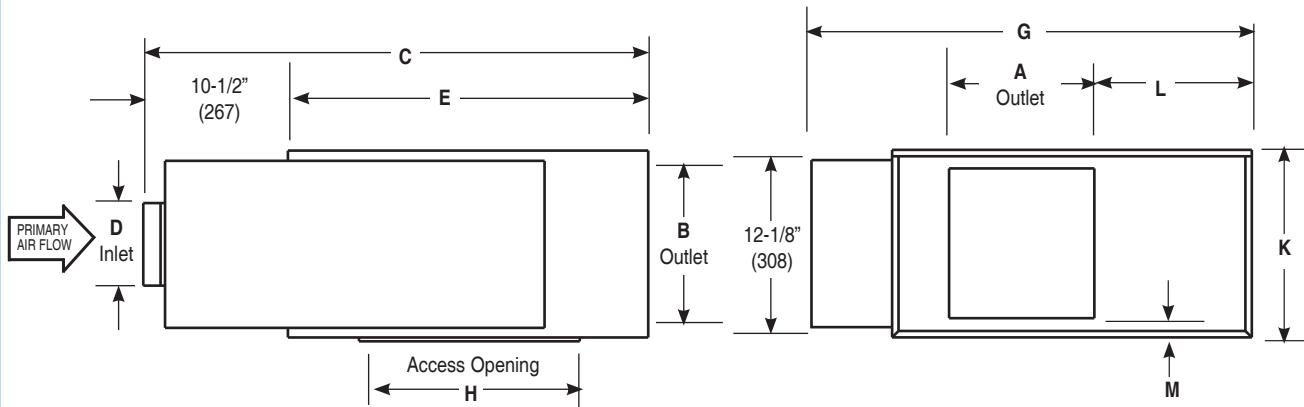

DIMENSIONS LISTED IN INCHES (Millimeters)

Fan Size	Inlet Size	Primary CFM (L/s)	Sec. CFM @ .25" E.S.P. (L/s)	Fan H.P.	Outlet		C	Inlet		E	G	H	J	K	L	M
					A	B		D	E							
B	06	500 (236)	550 (260)	1/3	6-3/4 (171)	7	40-5/8 (1032)	5-7/8 (149)	30	30	19-5/8 (498)	13-3/4 (349)	15	7-7/8 (200)	6-3/4 (171)	
C	07	700 (330)	800 (378)	1/3	8-1/4 (210)	(178)		6-7/8 (175)	(762)	(762)	(498)	(349)	(381)	(200)	(171)	
D	08	1000 (472)	1200 (566)	1/3	11-3/4 (298)	8 (203)	42-3/4 (1086)	7-7/8 (200)	40-1/2 (1029)	35-3/4 (908)	20 (508)	15-3/4 (400)	17-1/2 (445)	9-1/4 (235)	5-3/4 (146)	
E	10	1500 (708)	1800 (850)	1	11-1/4 (286)	7-1/2 (191)		9-7/8 (251)	32 (813)	41-3/4 (1048)	22 (559)	20-3/4 (527)		12-1/8 (308)	8-7/16 (214)	
F	12	2300 (1086)	2500 (1180)	1	13-1/8 (333)		42-1/4 (1073)	11-7/8 (302)		21-3/4 (552)	19-3/4 (502)		11-7/16 (281)	8-15/16 (227)		

NOTE: Outlet dimensions refer to the actual opening.

• FAN SIZES H and J — ECM

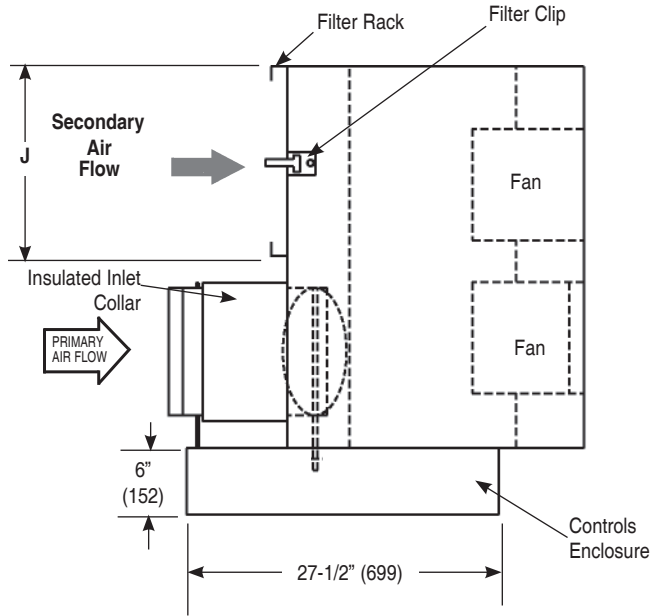

RIGHT HAND PRIMARY AIR UNIT SHOWN. LEFT HAND AVAILABLE.

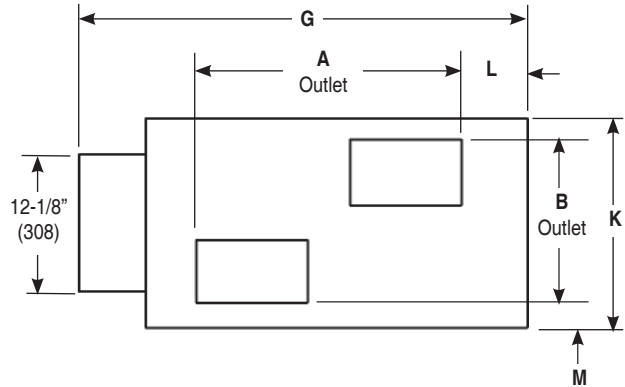
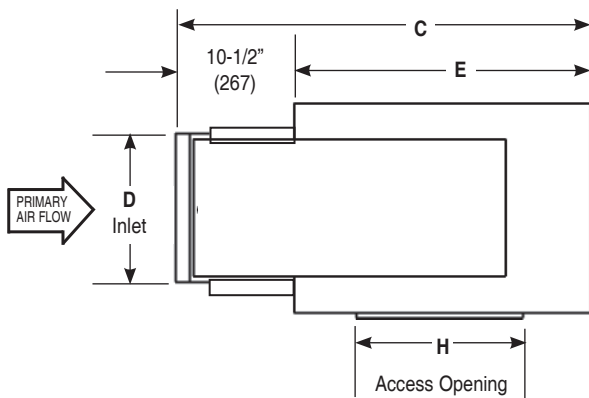

DIMENSIONS LISTED IN INCHES (Millimeters)

Fan Size	Inlet Size	Primary CFM (L/s)	Sec. CFM @ .25" E.S.P. (L/s)	Fan H.P.	Outlet			Inlet		E	G	H	J	K	L	M
					A	B	C	D								
H	14	3100 (1463)	3200 (1510)	3/4 (2)	36-1/4 (921)	17-1/2 (445)	41-1/2 (1054)	13-7/8 (352)	30 (762)	56 (1422)	17-3/4 (451)	27-7/8 (708)	18-1/4 (463)	6-3/4 (171)	9-3/4 (248)	
J	16	4200 (1982)	4200 (1982)	1 (2)				15-7/8 (403)								

NOTE: Outlet dimensions refer to the actual opening.