

Models **ACF w/o Coil**
ACW w/Hot Water Coil
ACE w/Electric Coil

The **Carnes** constant volume fan terminal unit provides constant air volume to the space while retaining the advantages of a variable air volume system.

The primary air control assembly operates in the same manner as a standard throttling control valve when cooling loads are high. As cooling loads diminish the integral blower(s) induces warm ceiling plenum air to maintain constant air volume.

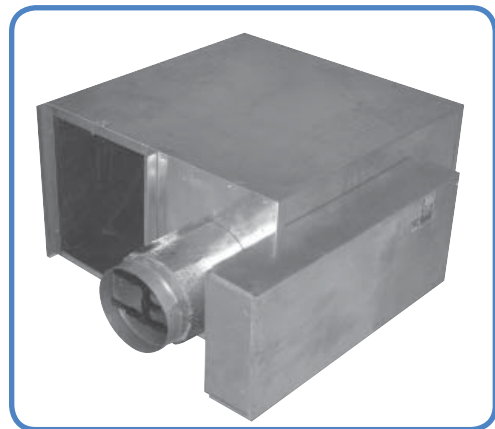

Features Include:

- Air flow capacities to 4130 CFM.
- Durable 22 gauge galvanized steel casing construction.
- Bottom access panel for internal components.
- Flange or slip and drive discharge connections.
- Forward curved centrifugal type fan assemblies with thermally protected, Permanent Split Capacitor or ECM type, fractional horsepower motors. Multiple voltages available.
- Adjustable SCR fan speed control.
- Fan/motor assemblies are isolated from the casing using rubber isolators to minimize vibration transmission.
- Low leakage primary air damper design.
- Secondary air filter rack.
- Performance data based on tests conducted in accordance with AHRI Standard 880-2008.
- Air flow switch.
- All units are equipped with pressure independent pneumatic or electronic controls.
- Field adjustable P/E switch with pneumatic controls.
- Tri-Averaging type velocity sensor and calibration chart for measuring air flow through the primary air damper.
- Insulation is 1" thick, 1-1/2 lb. dual density fiberglass with surface treated to prevent air erosion, UL listed and meets NFPA 90A requirements.
- Damper controls and fan controls are located in one enclosure.
- AHRI listed.
- Optional ETL listing.
- Optional secondary air sound baffle. Sound baffle is factory attached to secondary air inlet.
- Optional one to four row hot water coils (Model ACW). Coil is factory attached to the unit discharge.
- Optional one or two stage electric reheat coils (Model ACE). Coil is factory attached to unit discharge.
- Optional secondary air filters, Class I (re-usable) or Class II (throw away).
- Optional non-fused or fused fan disconnect switch.
- Optional foil coated insulation.
- Optional fiber-free liner.
- Optional dual wall.

Available Modules:

- Basic control unit — **Model ACF**.
- Basic control unit with hot water coil — **Model ACW**.
- Basic control unit with electric coil — **Model ACE**.



IAQ Insulation
Available

FAN CURVES CFM vs EXTERNAL STATIC PRESSURE

FAN SIZE B — AC 06
1/6 HP Motor PSC

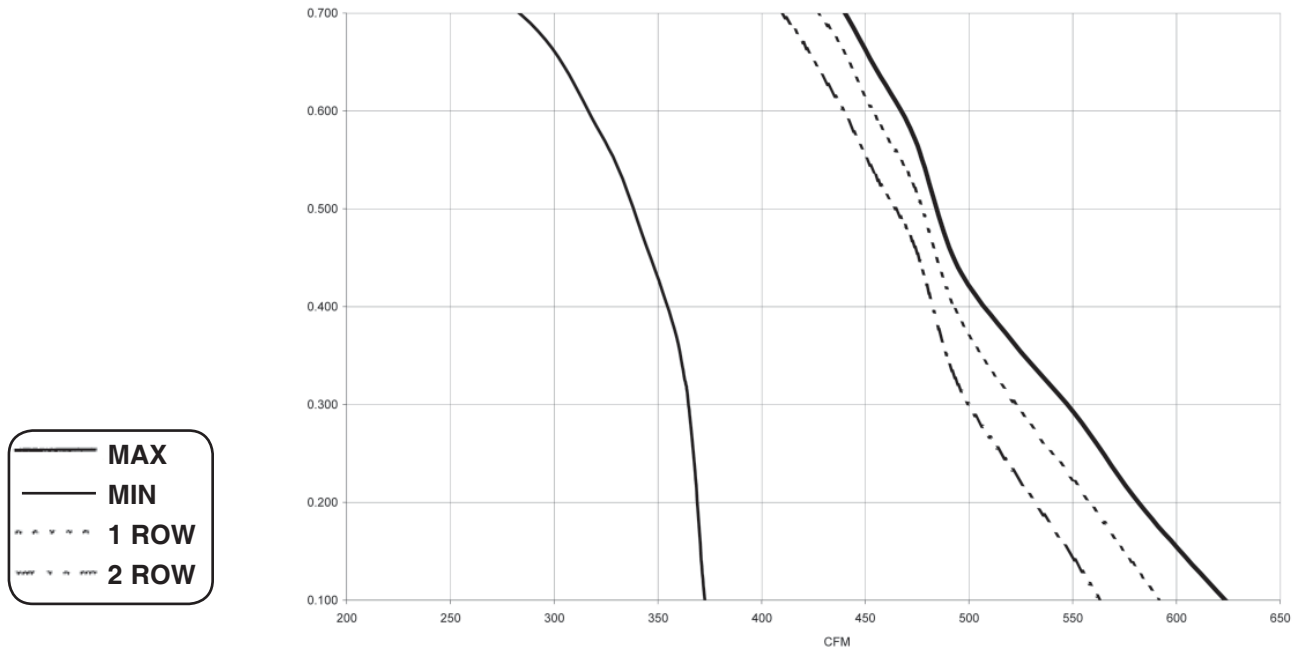

FAN SIZE C — AC 07
1/6 HP Motor PSC

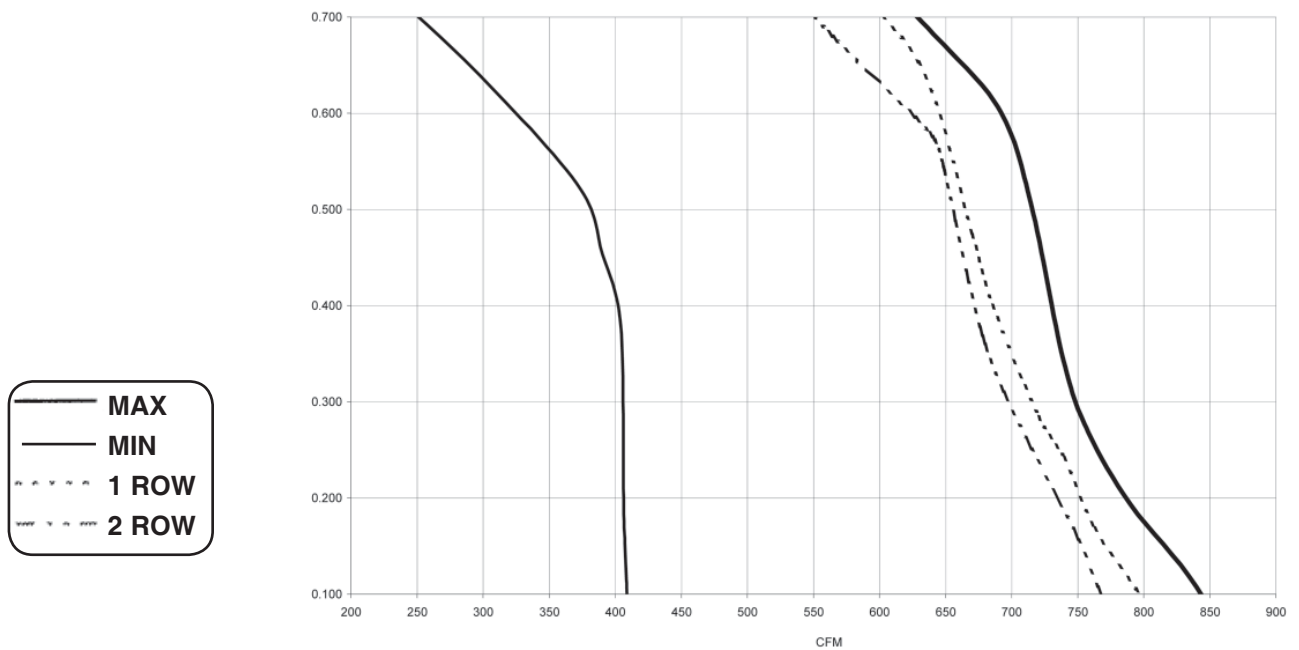

- NOTES:**
1. External static pressure (ESP) consists of down stream duct work, coils, flex duct, etc.
 2. Pressure drop due to heating coils are treated as external static pressure
 3. For proper operation, the downstream ESP must be at least 0.20" w.g.

Fan Powered Units

FAN CURVES CFM vs EXTERNAL STATIC PRESSURE

FAN SIZE D — AC 08

1/4 HP Motor PSC

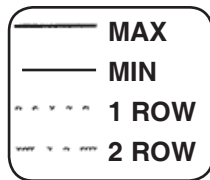
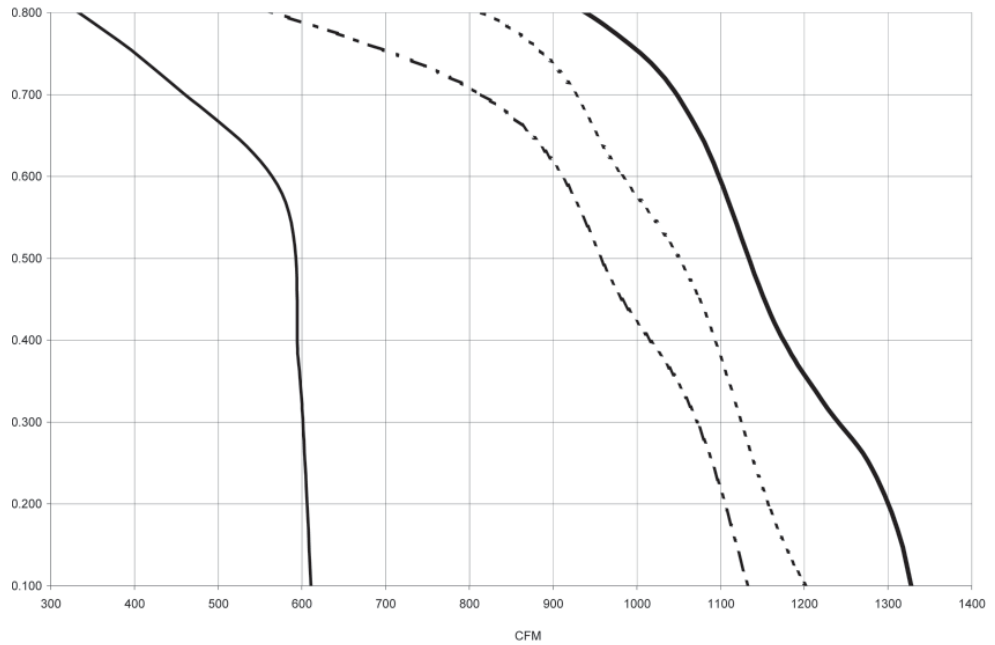

FAN SIZE E — AC 10

1/2 HP Motor PSC

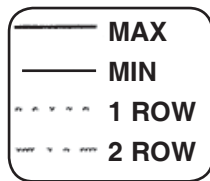
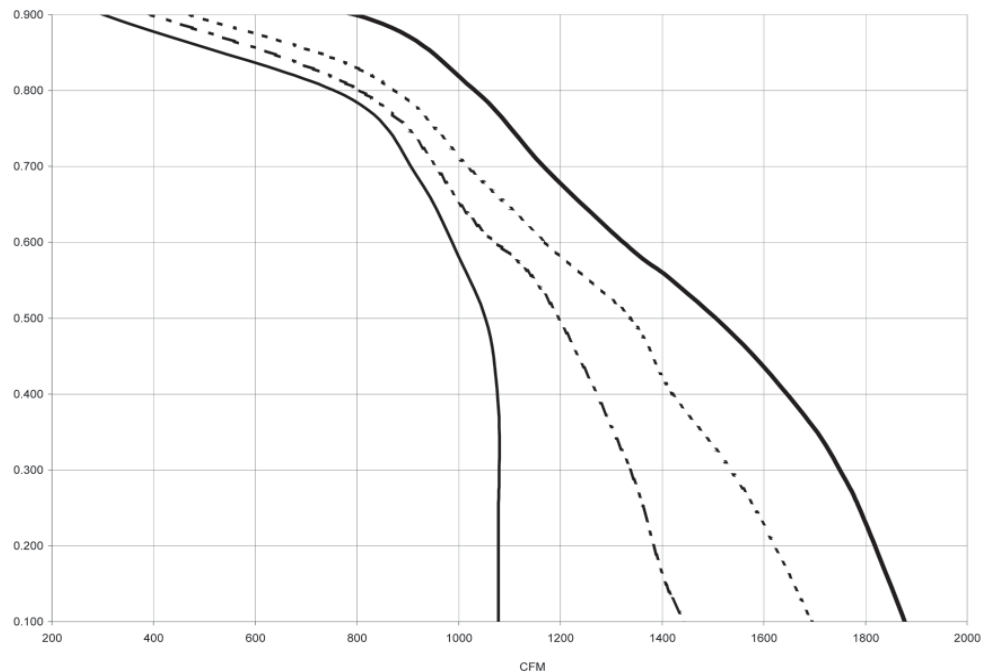

- NOTES:**
1. External static pressure (ESP) consists of down stream duct work, coils, flex duct, etc.
 2. Pressure drop due to heating coils are treated as external static pressure
 3. For proper operation, the downstream ESP must be at least 0.20" w.g.

FAN CURVES CFM vs EXTERNAL STATIC PRESSURE

FAN SIZE F — AC 12
3/4 HP Motor PSC

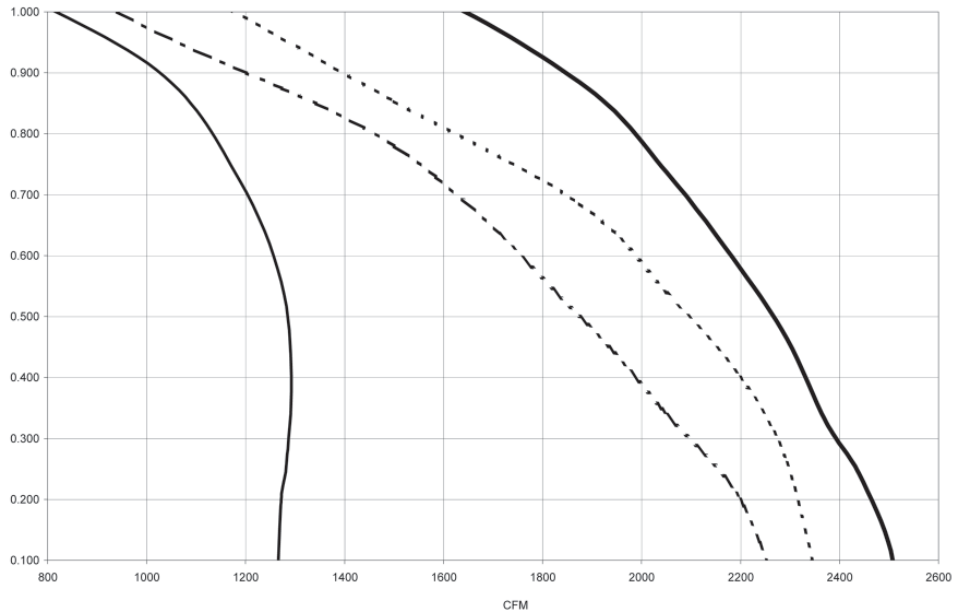
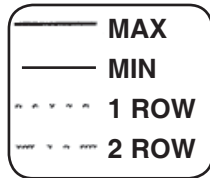

FAN SIZE G — AC 14/16
1 HP Motor PSC

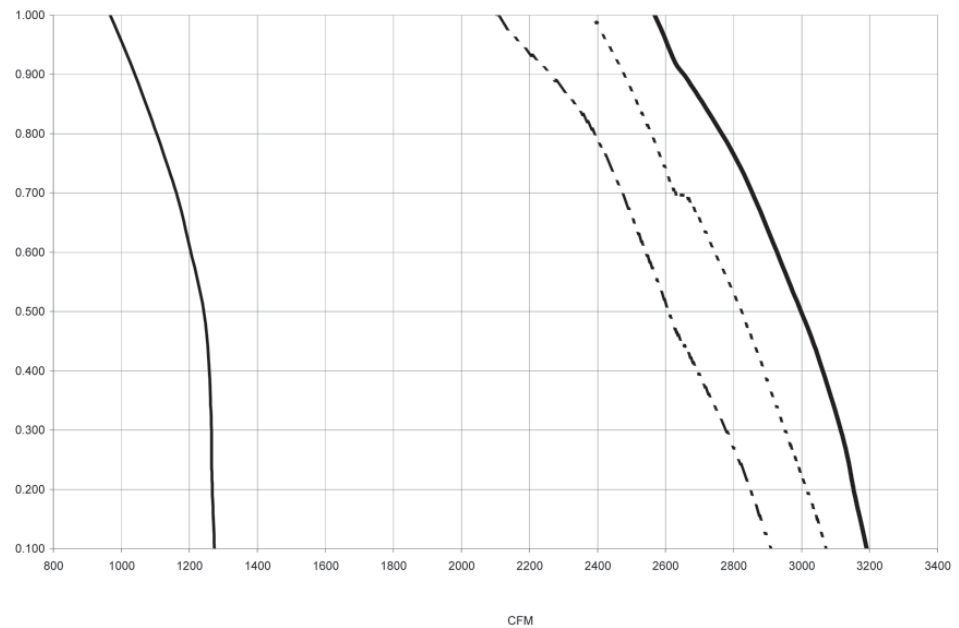
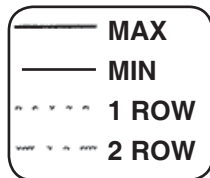

- NOTES:**
1. External static pressure (ESP) consists of down stream duct work, coils, flex duct, etc.
 2. Pressure drop due to heating coils are treated as external static pressure
 3. For proper operation, the downstream ESP must be at least 0.20" w.g.

FAN CURVES CFM vs EXTERNAL STATIC PRESSURE

FAN SIZE J — AC 16
(2) 3/4 HP Motor PSC

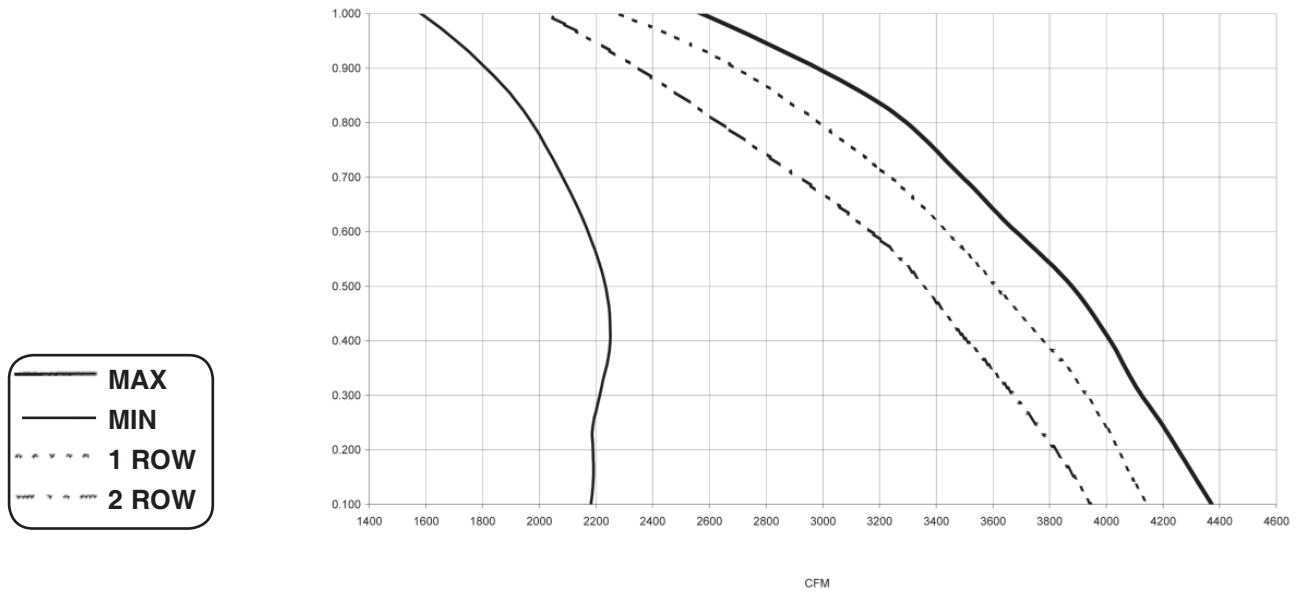

- NOTES:**
1. External static pressure (ESP) consists of down stream duct work, coils, flex duct, etc.
 2. Pressure drop due to heating coils are treated as external static pressure
 3. For proper operation, the downstream ESP must be at least 0.20" w.g.

Model ACFJ/ACEJ
Fan Power Terminal Units

Unit Size	Air Flow CFM	Min. ΔP_s in w.g.	Discharge Sound Max. NC					Radiated Sound Max. NC				
			Fan Only	0.5" w.g.	1.0" w.g.	1.5" w.g.	3.0" w.g.	Fan Only	0.5" w.g.	1.0" w.g.	1.5" w.g.	3.0" w.g.
6 (B)	350	0.155	22	24	24	26	26	28	31	31	31	32
	425	0.223	26	28	28	28	28	32	33	33	33	33
	475	0.293	30	31	31	31	31	35	37	37	37	37
	550	0.403	35	36	35	35	35	39	40	40	40	40
7 (C)	450	0.105	16	17	17	18	20	26	24	27	28	33
	550	0.151	23	24	24	24	27	32	32	33	33	35
	650	0.210	28	31	31	31	32	39	37	39	40	40
	750	0.283	32	33	33	35	36	41	41	41	44	45
8 (D)	850	0.190	20	26	27	27	28	28	35	35	36	38
	1000	0.258	24	30	31	32	33	33	38	41	42	42
	1150	0.344	28	33	36	36	36	33	41	44	44	46
	1275	0.422	32	36	36	39	39	37	43	46	48	48
10 (E)	1200	0.112	25	27	28	30	31	35	36	39	40	43
	1400	0.147	30	31	33	35	35	37	41	43	44	46
	1600	0.192	32	35	36	37	39	41	46	46	48	50
	1780	0.241	35	36	37	39	41	44	49	49	50	53
12 (F)	2000	0.180	32	37	40	43	44	40	48	52	54	56
	2150	0.201	34	40	43	45	46	41	49	53	54	57
	2300	0.242	36	41	44	46	48	44	52	54	57	59
	2430	0.274	38	41	45	46	48	46	54	56	57	61
14/16 (G)	2500	0.118	33	36	39	40	41	48	52	54	54	57
	2700	0.137	34	37	40	41	43	48	53	54	56	57
	2900	0.162	35	39	43	43	45	50	53	56	57	58
	3100	0.180	39	40	43	45	46	54	56	57	58	61
16 (J)	3000	0.164	32	34	36	38	41	42	47	49	50	54
	3400	0.211	35	35	38	41	44	44	52	50	53	57
	3800	0.256	38	40	41	43	46	46	49	54	55	59
	4200	0.291	40	44	46	47	49	48	54	56	57	60

- NOTES:**
1. ΔP_s static pressure difference from inlet to discharge.
 2. The lowest value of ΔP_s is the minimum pressure required to deliver CFM shown with primary damper in wide open position.
 3. ΔP_s does not include hot water or electric coils.
 4. (—) indicates NC levels less than 10.

NC Levels are derived from tests conducted in accordance with AHRI Standard 880-2008 and are calculated in accordance with AHRI Standard 885-2008 as application data based on the following:

Discharge NC levels are based on —

- a) 5 foot rectangular duct lined with 1" fiberglass insulation.
- b) 5 foot lined flex duct (8" diameter).
- c) Flow division.
- d) Space effect factor (2400ft₃) at 5 feet from outlet.
- e) End reflection.
- f) Environmental adjustment factor.

Radiated NC levels are based on —

- a) Plenum/ceiling effect - 5/8" mineral fiber tile, 35 lb/ft₃ - 3 foot plenum
- b) Environmental adjustment factor.

NC is not part of the AHRI 880 Certified Program.

Fan Powered Units

Sound Data (Sound Power by Octave Band)

Discharge Sound Power

Model ACFJ/ACEJ

Fan Power Terminal Units

Fan Powered Units

Inlet (Fan) Size	Air Flow CFM	Fan Only Octave Band							Primary Air							Primary Air							Primary Air							Primary Air						
		Fan Only Octave Band							P _s (0.5 w.g.) Octave Band							P _s (1.0 w.g.) Octave Band							P _s (1.5 w.g.) Octave Band							P _s (3.0 w.g.) Octave Band						
		2	3	4	5	6	7	2	3	4	5	6	7	2	3	4	5	6	7	2	3	4	5	6	7	2	3	4	5	6	7	2	3	4	5	6
6 (B)	350	69	58	56	55	52	48	71	60	57	56	55	50	71	60	58	56	55	50	72	61	59	57	56	51	72	61	59	58	57	52					
	425	72	61	60	57	56	52	74	63	60	59	58	53	74	63	60	59	58	53	74	63	60	59	58	53	74	64	61	60	60	54					
	475	75	63	62	60	58	55	76	65	62	61	60	56	76	65	62	61	60	56	76	65	62	61	60	56	76	65	62	61	61	56					
	550	79	68	64	64	62	59	80	69	65	64	63	59	79	69	65	64	63	59	79	69	65	64	63	60	79	69	65	64	63	60					
7 (C)	450	64	59	55	54	51	47	65	59	57	56	54	50	65	60	58	57	55	50	66	60	59	58	56	51	68	61	60	58	56	51					
	550	70	63	59	59	57	54	71	62	61	61	58	54	71	63	61	62	59	55	71	64	62	62	60	56	73	66	63	64	61	57					
	650	74	67	62	62	60	58	76	66	64	64	62	58	76	67	64	65	63	59	76	68	65	66	64	60	77	69	66	67	65	61					
	750	79	70	65	67	64	62	80	73	68	68	67	63	80	73	68	69	67	64	81	74	69	69	67	64	82	73	69	70	69	66					
8 (D)	850	70	62	63	62	59	55	74	65	66	66	64	61	75	66	66	66	64	61	75	67	66	66	64	61	76	68	68	67	65	61					
	1000	73	65	66	65	62	60	77	68	69	69	67	64	78	69	69	69	67	65	79	70	69	69	67	65	80	71	70	69	68	65					
	1150	76	68	68	68	66	63	80	71	71	72	70	67	82	73	71	72	70	67	82	73	71	71	69	67	82	73	72	71	70	67					
	1275	79	70	71	71	69	66	82	74	73	74	72	69	82	74	73	73	72	69	84	75	73	73	72	69	84	75	74	73	72	69					
10 (E)	1200	70	65	66	64	63	61	73	66	67	66	65	63	74	69	68	67	66	64	77	71	69	68	67	65	78	71	71	69	69	66					
	1400	75	69	71	69	68	66	78	71	72	71	70	68	80	73	73	71	71	69	81	74	73	72	71	69	81	76	64	63	63	70					
	1600	78	71	72	73	71	69	81	73	74	73	72	70	82	74	74	73	73	71	83	77	75	74	73	72	84	79	76	75	74	72					
	1780	79	73	74	74	74	72	82	76	76	74	74	72	83	77	76	75	75	73	84	79	77	75	75	73	86	81	79	76	76	74					
12 (F)	2000	76	70	72	74	71	69	83	75	75	75	73	72	85	78	76	77	75	73	87	80	77	77	75	74	88	81	78	78	76	74					
	2150	77	73	74	76	73	71	85	77	76	77	75	73	87	80	78	79	76	75	89	81	79	79	77	75	90	82	79	79	77	76					
	2300	79	74	75	78	75	73	86	78	77	79	76	75	88	80	79	80	78	76	90	82	80	80	78	77	91	84	81	81	79	77					
	2430	80	76	77	80	77	75	86	80	78	79	77	76	89	82	80	81	79	77	90	83	81	81	79	78	91	85	82	82	80	78					
14/16 (G)	2500	79	74	77	73	72	70	81	77	77	76	74	72	84	79	78	76	75	73	84	80	79	77	75	73	86	81	80	78	77	74					
	2700	79	75	79	75	73	71	83	77	79	77	75	73	85	80	79	78	76	74	86	81	80	78	77	75	87	83	81	79	78	75					
	2900	80	76	79	76	74	72	84	79	80	78	77	75	87	82	80	79	78	76	87	82	81	79	78	76	89	84	82	80	79	77					
	3100	84	78	79	79	77	75	85	80	80	80	78	76	87	83	81	81	79	77	89	84	82	81	80	78	90	85	82	82	80	78					
16 (J)	3000	77	73	73	73	71	69	78	74	74	74	73	71	80	77	75	77	76	73	82	79	76	78	78	75	84	81	77	80	80	77					
	3400	80	75	75	76	74	72	80	76	75	76	74	72	82	78	77	78	78	75	84	81	78	80	80	77	88	83	80	82	83	80					
	3800	80	78	76	78	76	75	84	80	78	78	77	76	84	81	79	80	80	78	86	83	80	81	82	79	89	85	81	84	85	82					
	4200	83	80	79	80	78	77	87	84	81	82	81	80	88	85	82	83	83	81	88	86	83	84	84	82	92	88	84	85	87	85					

- NOTES:**
1. Based on tests conducted in accordance with AHRI Standard 880-2008.
 2. Δ P_s static pressure difference from inlet to discharge.
 3. Δ P_s is the minimum pressure required to deliver CFM shown with primary damper in wide open position.
 4. Dash (—) indicates db level less than 10.



A Participating Member in the AHRI 880 Certification Program

Sound Data (Sound Power by Octave Band)

Radiated Sound Power

Model ACFJ/ACEJ

Fan Power Terminal Units

Inlet (Fan) Size	Air Flow CFM	Fan Only Octave Band							Primary Air							Primary Air							Primary Air							Primary Air						
									P _s (0.5 w.g.) Octave Band							P _s (1.0 w.g.) Octave Band							P _s (1.5 w.g.) Octave Band							P _s (3.0 w.g.) Octave Band						
		2	3	4	5	6	7	2	3	4	5	6	7	2	3	4	5	6	7	2	3	4	5	6	7	2	3	4	5	6	7					
6 (B)	350	65	58	49	44	39	35	67	59	50	46	41	37	67	59	51	47	43	39	67	59	52	48	45	42	68	60	55	52	49	50					
	425	68	60	51	47	42	39	69	62	52	48	44	40	69	62	53	49	45	41	69	62	54	50	46	43	69	62	56	53	51	50					
	475	70	62	53	49	44	41	72	63	54	50	46	42	72	63	55	50	46	42	72	64	56	51	48	45	72	64	58	54	52	50					
	550	73	66	55	52	48	45	74	67	57	53	49	46	74	67	57	53	49	46	74	67	58	54	50	47	74	67	59	56	53	51					
7 (C)	450	63	56	46	42	37	31	62	55	48	45	41	35	64	58	52	48	45	41	65	59	54	49	48	45	66	61	58	54	52	52					
	550	68	59	50	45	42	37	68	62	53	48	45	40	69	63	55	50	47	43	69	63	56	51	49	47	70	64	59	56	53	53					
	650	73	64	52	49	46	43	72	65	55	51	49	44	73	66	56	53	50	46	74	66	58	54	52	48	74	68	62	57	55	54					
	750	75	67	55	53	50	47	75	68	58	54	51	47	75	69	59	55	52	48	77	70	61	56	53	50	78	71	63	58	56	54					
8 (D)	850	62	59	52	47	43	39	67	65	56	54	49	46	68	65	58	54	49	46	69	66	58	54	50	47	70	68	63	58	54	51					
	1000	66	63	55	50	46	43	71	68	60	57	53	50	72	70	61	56	53	50	73	71	61	56	53	51	73	71	64	60	56	53					
	1150	68	63	57	52	49	47	73	70	62	58	55	53	75	73	64	59	55	53	76	73	65	59	55	53	76	74	66	61	57	55					
	1275	71	67	59	55	52	50	75	72	62	60	57	55	76	74	65	61	57	55	78	76	66	61	57	55	79	76	68	63	58	56					
10 (E)	1200	70	63	58	52	50	48	71	65	58	54	53	50	73	68	59	56	53	51	74	69	61	57	55	52	76	72	66	61	57	55					
	1400	72	66	60	55	53	51	75	70	62	57	56	53	76	71	63	58	57	55	77	72	65	59	57	55	79	74	67	62	59	57					
	1600	75	68	61	59	57	55	79	73	63	60	59	57	79	74	64	61	59	57	80	75	65	62	60	58	82	77	69	64	61	59					
	1780	77	71	63	61	59	58	81	75	65	62	61	59	81	77	67	63	61	60	82	77	68	63	62	60	84	79	70	65	63	61					
12 (F)	2000	74	68	63	60	56	53	80	73	66	61	58	55	83	77	68	64	60	57	85	79	69	64	61	58	86	80	73	67	63	59					
	2150	75	70	64	61	58	55	81	75	66	64	60	57	84	78	68	64	61	58	85	80	70	65	62	59	87	82	73	68	63	60					
	2300	77	71	66	63	60	57	83	77	68	65	62	58	85	79	70	66	63	60	87	81	71	66	63	60	89	83	74	69	65	61					
	2430	79	73	67	65	61	58	85	78	69	66	63	60	86	80	70	66	64	61	87	82	72	68	65	62	90	85	74	70	66	63					
14/16 (G)	2500	80	70	69	60	57	54	83	73	70	62	60	57	85	76	70	63	61	57	85	77	71	64	61	58	87	79	73	67	63	60					
	2700	80	71	69	62	58	55	84	74	70	63	61	57	85	76	70	64	61	58	86	78	71	65	63	59	87	80	74	67	63	60					
	2900	82	72	69	63	59	56	84	76	70	65	62	59	86	77	70	64	63	60	87	78	71	65	63	60	88	81	73	68	65	62					
	3100	85	74	69	65	61	59	86	76	70	65	63	60	87	78	71	66	64	61	88	80	72	66	64	62	90	82	74	68	68	63					
16 (J)	3000	75	71	66	64	60	55	79	75	69	68	64	60	81	77	71	69	66	61	82	78	73	71	68	64	85	81	76	73	70	65					
	3400	77	72	67	67	62	58	83	78	71	70	66	62	82	78	73	71	68	64	84	80	74	72	69	65	87	83	77	75	72	68					
	3800	79	74	69	69	64	60	80	77	70	68	65	61	85	81	74	73	70	66	85	82	75	74	71	67	88	85	79	77	74	70					
	4200	80	76	71	71	66	62	85	81	74	73	69	66	86	82	75	74	71	67	87	83	76	75	72	68	89	86	79	77	75	71					

- NOTES:**
1. Based on tests conducted in accordance with AHRI Standard 880-2008.
 2. ΔP_s static pressure difference from inlet to discharge.
 3. ΔP_s is the minimum pressure required to deliver CFM shown with primary damper in wide open position.
 4. Dash (—) indicates db level less than 10.



A Participating Member in the AHRI 880 Certification Program

Fan Powered Units

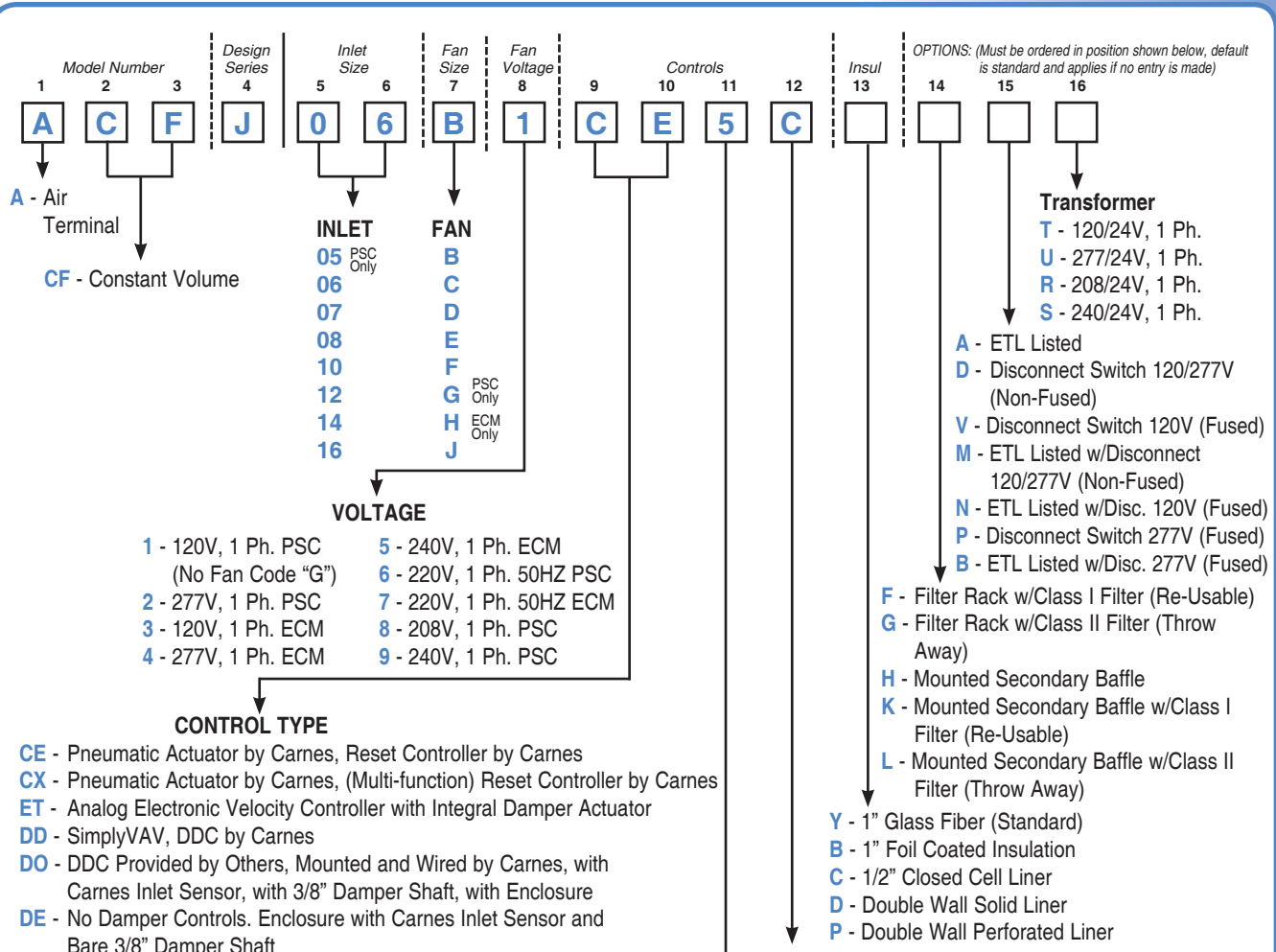

NOTE: Hand of controls is determined by facing the averaging flow sensor (inlet of the unit) with the supply air hitting the back of your head.

▼ **Electronic Thermostat**

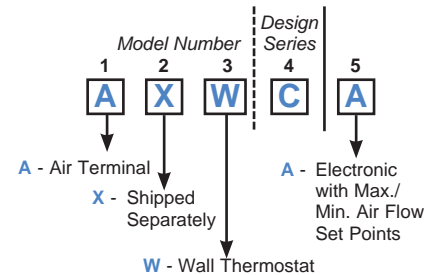

A Carnes Electronic Thermostat **must be ordered** with the ET Electronic Control Option.

▼ **Direct Digital Control (DD/DC/DM)**

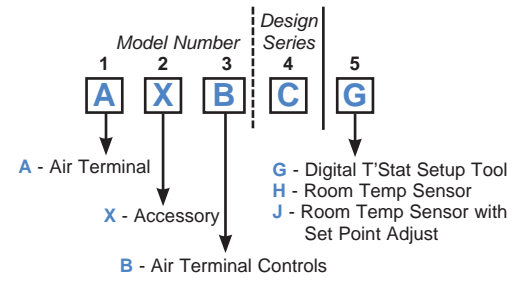

CONTROLS AND DAMPER ARRANGEMENT

- *1 - Normally Open - Right Hand Controls (Electronic/DO, DE, ET) (All Pneumatic Control Types for Reverse Acting Thermostat)
- *2 - Normally Open - Left Hand Controls (Electronic/DO, DE, ET) (All Pneumatic Control Types for Reverse Acting Thermostat)
- 3 - Normally Closed - Right Hand Controls (All Pneumatic Control Types for Direct Acting Thermostat)
- 4 - Normally Closed - Left Hand Controls (All Pneumatic Control Types for Direct Acting Thermostat)
- 5 - Normally Open - Right Hand Controls (All Pneumatic Control Types for Direct Acting Thermostat)
- 6 - Normally Open - Left Hand Controls (All Pneumatic Control Types for Direct Acting Thermostat)
- 7 - Normally Closed - Right Hand Controls (All Pneumatic Control Types for Reverse Acting Thermostat)
- 8 - Normally Closed - Left Hand Controls (All Pneumatic Control Types for Reverse Acting Thermostat)

* Electronic and DDC Units **DO NOT** fail open. '1' or '2' is used for Right or Left Hand Only. Electric/Electronic Units are shipped with the Damper in the Open Position.

• FAN SIZES B - G — PSC

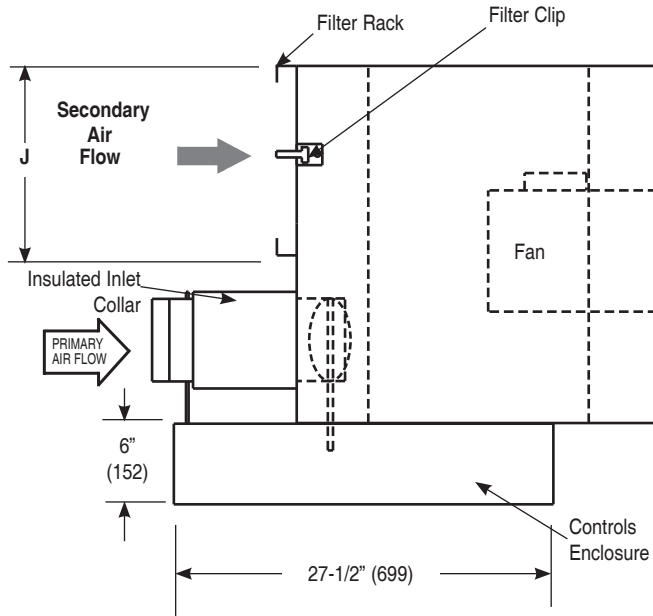

RIGHT HAND PRIMARY AIR UNIT SHOWN. LEFT HAND AVAILABLE.

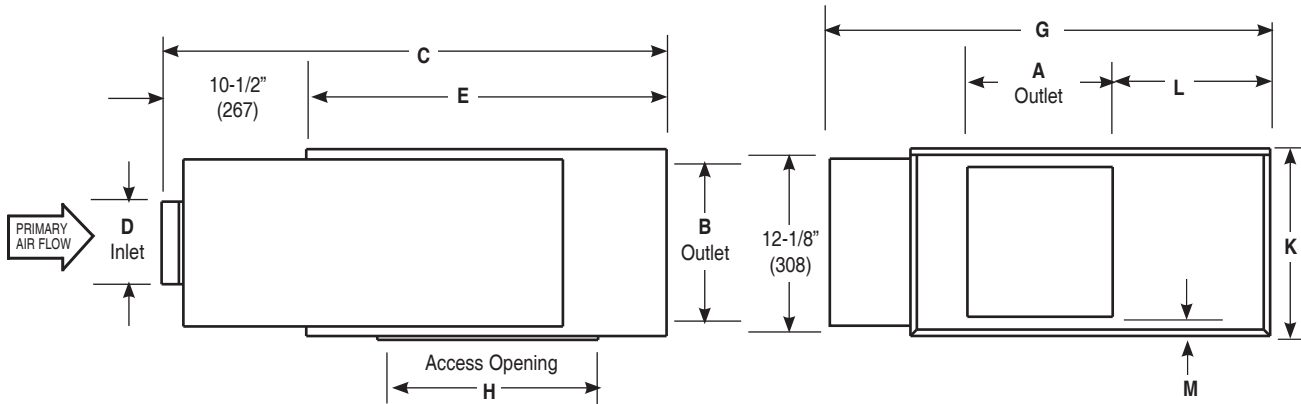

DIMENSIONS LISTED IN INCHES (Millimeters)

Fan Size	Inlet Size	Primary CFM (L/s)	Sec. CFM @ .25" E.S.P. (L/s)	Fan H.P.	Outlet			Inlet D	E	G	H	J	K	L	M
					A	B	C								
B	05	350 (165)	550 (260)	1/6	6-3/4 (171)	7 (178)	40-5/8 (1032)	4-7/8 (124)	30 (762)	30 (762)	19-5/8 (498)	13-3/4 (349)	15 (381)	7-7/8 (200)	6-3/4 (171)
B	06	500 (236)	550 (260)	1/6	8-1/4 (210)			6-7/8 (175)							
C	07	700 (330)	750 (354)	1/6	11-3/4 (298)			8 (203)							
D	08	1000 (472)	1275 (602)	1/4	11-1/4 (286)	7-1/2 (191)	42-3/4 (1086)	9-7/8 (251)	32 (813)	41-3/4 (1048)	22 (559)	20-3/4 (527)	17-1/2 (445)	12-1/8 (308)	8-7/16 (214)
E	10	1500 (708)	1780 (840)	1/2	13-1/8 (333)			42-1/4 (1073)							
F	12	2300 (1086)	2430 (1147)	3/4	15-3/4 (400)	8-1/2 (216)	48-7/8 (1241)	13-7/8 (352)	38-1/4 (972)	45-13/16 (1164)	27-3/4 (705)	17-3/4 (451)	20 (508)	12-1/2 (318)	9-15/16 (252)
G	14	3100 (1463)	3100 (1463)	1	15-3/4 (400)	8-1/2 (216)	48-7/8 (1241)	15-7/8 (403)	38-1/4 (972)	45-13/16 (1164)	27-3/4 (705)	17-3/4 (451)	20 (508)	12-1/2 (318)	9-15/16 (252)
G	16	4200 (1982)			15-3/4 (400)	8-1/2 (216)	48-7/8 (1241)	15-7/8 (403)	38-1/4 (972)	45-13/16 (1164)	27-3/4 (705)	17-3/4 (451)	20 (508)	12-1/2 (318)	9-15/16 (252)

NOTE: Outlet dimensions refer to the actual opening.

• FAN SIZE J — PSC

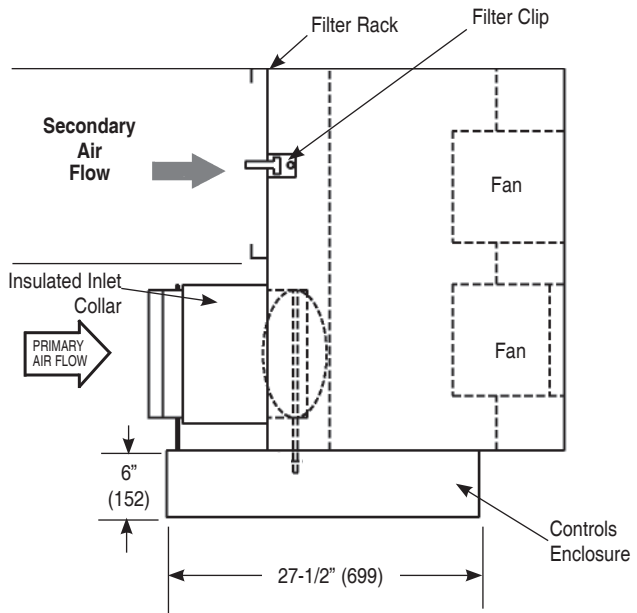

RIGHT HAND PRIMARY AIR UNIT SHOWN. LEFT HAND AVAILABLE.

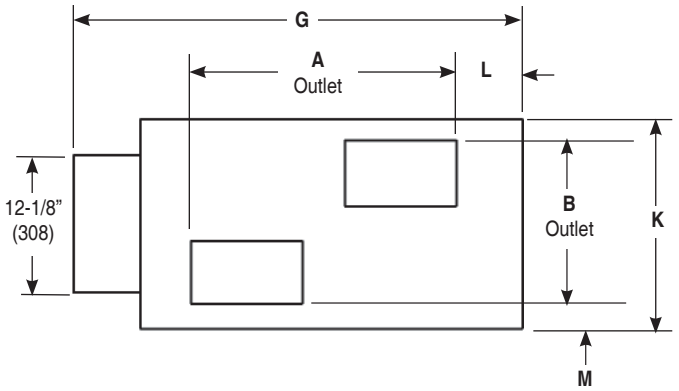
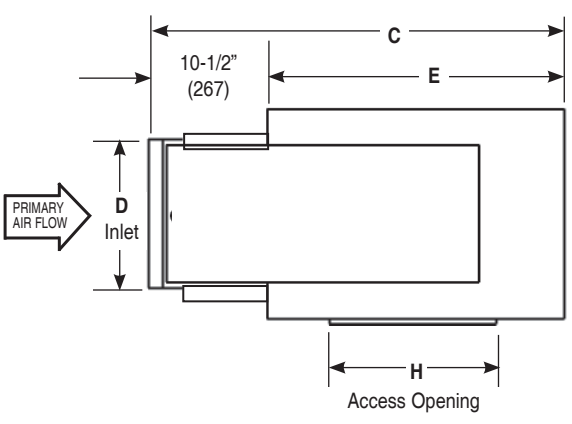

DIMENSIONS LISTED IN INCHES (Millimeters)															
Fan Size	Inlet Size	Primary CFM (L/s)	Sec. CFM @ .25" E.S.P. (L/s)	Fan H.P.	Outlet		C	Inlet		G	H	J	K	L	M
					A	B		D	E						
J	16	4200 (1982)	4130 (1949)	3/4 (2)	36-1/4 (921)	17-1/2 (445)	41-1/2 (1054)	15-7/8 (403)	30 (762)	56 (1422)	17-3/4 (451)	27-7/8 (708)	18-1/4 (463)	6-3/4 (171)	9-3/4 (248)

Note: Outlet dimensions refer to the actual opening.

Fan Powered Units