

SINGLE DUCT AIR TERMINAL – PRESSURE DEPENDENT PNEUMATIC CONTROL OPTION - CA3C, CA4C, CM3C, and CM4C

—————	BY CARNES
- - - - -	BY OTHERS
— · — · —	OPTIONAL

ITEM	PART NO.	DESCRIPTION
1	AXBAG	ACTUATOR (8–13 PSI)

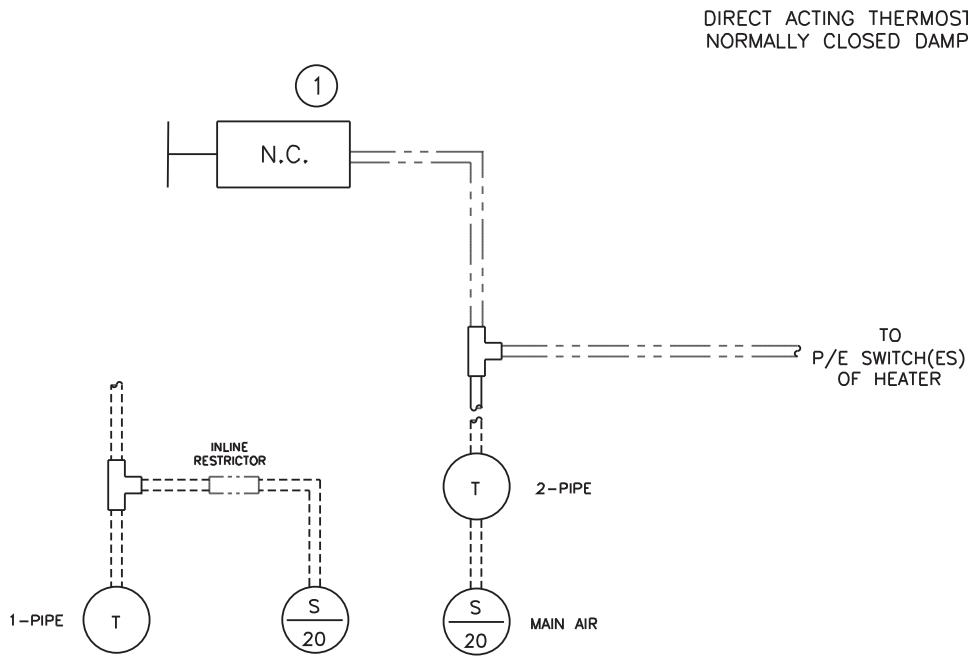

SEQUENCE OF OPERATION

WITH AN INCREASE IN ROOM TEMPERATURE, THERMOSTAT PRESSURE IS INCREASED CAUSING THE DAMPER TO OPEN TOWARDS THE MAXIMUM CFM SETTING TO SATISFY ROOM SET-POINT.

WITH A DECREASE IN ROOM TEMPERATURE, THERMOSTAT PRESSURE IS DECREASED CAUSING THE DAMPER TO CLOSE TOWARDS THE MINIMUM CFM SETTING TO SATISFY ROOM SET-POINT.

THE "CA" OPTION INCLUDES MECHANICAL STOPS FOR FIELD ADJUSTABLE MINIMUM AND MAXIMUM SETTINGS.

WHEN THE SYSTEM IS DESIGNED WITH REHEAT, HEATING STAGES ARE ENERGIZED AT THE APPROPRIATE PRESSURE SETTINGS.

CONTROL DIAGRAM

