

▼ Model AVE

The **Carnes Model AVE** is available as a basic control unit with electric reheat and open end discharge, with an optional attenuator module.

This unit offers low pressure drop, low sound levels, and valve characteristics which create stable control conditions within the conditioned space.

Features Include:

- Air flow capacities from full shut-off to 7,300 CFM (0-3,000 FPM for each unit size).
- Open-end discharge units are provided with slip and drive connections for easy installation.
- Thermally and acoustically insulated casing meets **UL** and **NFPA** standards. (Electric coil is uninsulated).
- Low leakage damper design.
- Pneumatic, electric, electronic, or manual control options available.
- Tri-Averaging type air flow sensor at inlet of unit.
- Optional pressure independent and pressure dependent controls.
- Optional hanger brackets.
- Optional internal foil faced insulation.
- Optional fiber-free liner.
- Optional Sterigard.
- Optional dual wall.
- Optional external insulation.
- Optional controls enclosure.
- Optional access panel for component inspection.
- AHRI certified product.

Available Modules:

- Basic Control Unit with attached or unattached electric reheat coil — **Model AVE**
- Sound Attenuator — **Model AXA**



IAQ Insulation
Available



A Participating Member
in the AHRI 880
Certification Program

AVE

Discharge and Radiated (NC) Noise Criteria

| Inlet Size (Inches) | CFM | Minimum Pressure Drop (Damper Full Open) | |
|---------------------|------|------------------------------------------|-----------------------|
| | | Min. Δ P _s | Min. Δ P _t |
| | | Basic Unit | Basic Unit |
| 5 | 75 | .028 | .048 |
| | 100 | .051 | .086 |
| | 200 | .192 | .334 |
| | 300 | .431 | .750 |
| | 350 | .554 | .989 |
| 6 | 110 | .020 | .039 |
| | 200 | .071 | .135 |
| | 300 | .149 | .293 |
| | 400 | .272 | .527 |
| | 500 | .395 | .795 |
| 7 | 140 | .010 | .027 |
| | 200 | .023 | .057 |
| | 400 | .093 | .229 |
| | 600 | .208 | .514 |
| | 700 | .261 | .676 |
| 8 | 185 | .009 | .025 |
| | 400 | .039 | .112 |
| | 600 | .083 | .247 |
| | 800 | .138 | .429 |
| | 1000 | .212 | .668 |
| 10 | 300 | .008 | .024 |
| | 500 | .013 | .057 |
| | 800 | .024 | .138 |
| | 1200 | .047 | .304 |
| | 1500 | .069 | .470 |
| 12 | 430 | .001 | .016 |
| | 800 | .003 | .056 |
| | 1200 | .005 | .125 |
| | 1800 | .007 | .276 |
| | 2300 | .009 | .448 |
| 14 | 600 | .004 | .021 |
| | 1000 | .006 | .052 |
| | 1600 | .011 | .128 |
| | 2400 | .024 | .289 |
| | 3100 | .036 | .478 |
| 16 | 780 | .005 | .021 |
| | 1600 | .016 | .082 |
| | 2400 | .041 | .189 |
| | 3600 | .089 | .422 |
| | 4200 | .120 | .573 |
| 18 | 1100 | .001 | .016 |
| | 2300 | .006 | .069 |
| | 3600 | .024 | .179 |
| | 4500 | .038 | .280 |
| | 5500 | .056 | .417 |
| 24 | 1480 | .000 | .005 |
| | 3200 | .040 | .038 |
| | 4800 | .090 | .086 |
| | 6000 | .140 | .138 |
| | 7300 | .200 | .209 |

| Min. Δ P _s (Damper Full Open) | | | 1.0" Δ P _s | | | 1.5" Δ P _s | | | 3.0" Δ P _s | | |
|------------------------------------------|-----------|---------|-----------------------|-----------|---------|-----------------------|-----------|---------|-----------------------|-----------|---------|
| Δ Pt | Disch. NC | Rad. NC | Δ Pt | Disch. NC | Rad. NC | Δ Pt | Disch. NC | Rad. NC | Δ Pt | Disch. NC | Rad. NC |
| .048 | — | — | 1.020 | — | — | 1.520 | — | 13 | 3.020 | 13 | 20 |
| .086 | — | — | 1.035 | — | 11 | 1.535 | 10 | 13 | 3.035 | 13 | 20 |
| .334 | — | — | 1.142 | 19 | 19 | 1.642 | 22 | 22 | 3.142 | 25 | 24 |
| .750 | 13 | 19 | 1.319 | 28 | 24 | 1.819 | 30 | 28 | 3.319 | 33 | 30 |
| .989 | 14 | 22 | 1.435 | 28 | 27 | 1.935 | 30 | 28 | 3.435 | 34 | 32 |
| .039 | — | — | 1.019 | — | 13 | 1.519 | — | 17 | 3.020 | 14 | 24 |
| .135 | — | — | 1.064 | 16 | 19 | 1.564 | 18 | 19 | 3.064 | 21 | 25 |
| .293 | — | — | 1.144 | 20 | 22 | 1.644 | 24 | 24 | 3.144 | 30 | 26 |
| .527 | — | 13 | 1.256 | 22 | 22 | 1.756 | 24 | 26 | 3.256 | 34 | 31 |
| .795 | 15 | 19 | 1.400 | 26 | 27 | 1.939 | 27 | 28 | 3.400 | 35 | 33 |
| .027 | — | — | 1.016 | — | 10 | 1.517 | — | 13 | 3.017 | 15 | 20 |
| .057 | — | — | 1.034 | 14 | 13 | 1.534 | 16 | 16 | 3.034 | 19 | 20 |
| .229 | — | — | 1.135 | 18 | 20 | 1.636 | 23 | 23 | 3.136 | 34 | 31 |
| .514 | — | 15 | 1.305 | 26 | 27 | 1.806 | 26 | 30 | 3.306 | 34 | 34 |
| .676 | — | 18 | 1.415 | 22 | 30 | 1.916 | 26 | 31 | 3.416 | 33 | 35 |
| .025 | — | — | 1.016 | 10 | 14 | 1.515 | 11 | 15 | 3.018 | 17 | 20 |
| .112 | — | — | 1.073 | 17 | 19 | 1.573 | 21 | 24 | 3.073 | 27 | 31 |
| .247 | — | — | 1.164 | 19 | 23 | 1.664 | 25 | 27 | 3.164 | 35 | 36 |
| .429 | — | 13 | 1.292 | 22 | 25 | 1.791 | 27 | 30 | 3.291 | 36 | 37 |
| .668 | 11 | 20 | 1.456 | 25 | 28 | 1.955 | 29 | 32 | 3.455 | 36 | 38 |
| .024 | — | — | 1.016 | 15 | 20 | 1.516 | 16 | 22 | 3.016 | 21 | 25 |
| .057 | — | — | 1.045 | 17 | 21 | 1.544 | 24 | 27 | 3.045 | 28 | 34 |
| .138 | — | — | 1.114 | 17 | 23 | 1.614 | 23 | 27 | 3.114 | 34 | 38 |
| .304 | — | 15 | 1.257 | 24 | 30 | 1.756 | 28 | 31 | 3.257 | 33 | 36 |
| .470 | 10 | 22 | 1.401 | 28 | 31 | 1.901 | 31 | 35 | 3.401 | 36 | 39 |
| .016 | — | — | 1.015 | 17 | 22 | 1.515 | 19 | 25 | 3.015 | 22 | 28 |
| .056 | — | — | 1.053 | 15 | 23 | 1.553 | 23 | 28 | 3.053 | 34 | 36 |
| .125 | — | — | 1.119 | 18 | 24 | 1.619 | 22 | 28 | 3.119 | 34 | 36 |
| .276 | — | 23 | 1.269 | 22 | 27 | 1.769 | 27 | 32 | 3.269 | 34 | 37 |
| .448 | 14 | 31 | 1.439 | 25 | 30 | 1.939 | 29 | 33 | 3.439 | 36 | 40 |
| .021 | — | — | 1.017 | 17 | 20 | 1.516 | 23 | 24 | 3.017 | 28 | 31 |
| .052 | — | — | 1.046 | 17 | 22 | 1.546 | 24 | 27 | 3.046 | 35 | 35 |
| .128 | — | 10 | 1.118 | 19 | 22 | 1.618 | 24 | 27 | 3.118 | 35 | 38 |
| .289 | 10 | 25 | 1.265 | 27 | 30 | 1.765 | 28 | 35 | 3.265 | 35 | 39 |
| .478 | 21 | 32 | 1.442 | 31 | 35 | 1.942 | 34 | 35 | 3.442 | 38 | 43 |
| .021 | — | — | 1.015 | 16 | 21 | 1.516 | 19 | 25 | 3.018 | 23 | 28 |
| .082 | — | — | 1.065 | 17 | 21 | 1.566 | 22 | 27 | 3.066 | 35 | 37 |
| .189 | — | 19 | 1.147 | 22 | 28 | 1.648 | 25 | 31 | 3.148 | 35 | 36 |
| .422 | 24 | 30 | 1.332 | 31 | 30 | 1.833 | 31 | 35 | 3.333 | 37 | 40 |
| .573 | 25 | 35 | 1.452 | 35 | 36 | 1.953 | 37 | 36 | 3.453 | 41 | 43 |
| .016 | — | — | 1.015 | 16 | 22 | 1.514 | 19 | 24 | 3.014 | 25 | 32 |
| .069 | — | — | 1.063 | 21 | 27 | 1.563 | 28 | 30 | 3.063 | 36 | 39 |
| .179 | 16 | 35 | 1.155 | 25 | 31 | 1.654 | 30 | 35 | 3.155 | 38 | 41 |
| .280 | 22 | 38 | 1.242 | 31 | 39 | 1.741 | 34 | 40 | 3.241 | 40 | 44 |
| .417 | 31 | 42 | 1.361 | 36 | 41 | 1.861 | 38 | 43 | 3.361 | 42 | 48 |
| .005 | — | — | 1.010 | 21 | 32 | 1.511 | 27 | 37 | 3.011 | 30 | 46 |
| .038 | — | 22 | 1.050 | 22 | 31 | 1.550 | 27 | 36 | 3.050 | 37 | 48 |
| .086 | 21 | 38 | 1.112 | 28 | 35 | 1.613 | 30 | 37 | 3.112 | 38 | 45 |
| .138 | 28 | 40 | 1.175 | 33 | 39 | 1.676 | 35 | 41 | 3.175 | 40 | 48 |
| .209 | 37 | 47 | 1.259 | 36 | 41 | 1.760 | 40 | 46 | 3.260 | 44 | 48 |

- NOTES:**
1. Δ P_s static pressure difference from inlet to discharge.
 2. Δ P_s is the minimum pressure required to deliver CFM shown with the primary damper in wide open position.
 3. Δ P_t is the total pressure difference from inlet to discharge.
 4. Dash (—) indicates NC level less than 10.

NC levels are derived from tests conducted in accordance with AHRI Standard 880-2008 and are calculated in accordance with AHRI Standard 885-2008 as application data based on the following:

- Discharge NC levels are based on —
- a) 5 foot rectangular duct lined with 1" fiberglass insulation.
 - b) 5 foot lined flex duct (8" diameter).
 - c) Flow division.
 - d) Space effect factor (2400 ft³) at 5 feet from outlet.
 - e) End reflection.
 - f) Environmental adjustment factor.

- Radiated NC levels are based on —
- a) Plenum / ceiling effect - 5/8" mineral fiber tile, 35 lb / ft³ - 3 foot plenum.
 - b) Environmental adjustment factor.

NC is not part of the AHRI 880 Certification Program.

Sound Data (Sound Power by Octave Band)

Discharge Sound Power

| Inlet Size (Inches) | CFM | ΔP_s | Minimum ΔP_s | | | | | | | 1.0" ΔP_s | | | | | | | 1.5" ΔP_s | | | | | | | 3.0" ΔP_s | | | | | | |
|---------------------|------|--------------|---------------------------------|-----|-----|-----|-----|-----|-----|---------------------------------|-----|-----|-----|-----|-----|-----|---------------------------------|-----|-----|-----|-----|-----|-----|---------------------------------|-----|-----|-----|-----|-----|-----|
| | | | Sound Power (db) by Octave Band | | | | | | | Sound Power (db) by Octave Band | | | | | | | Sound Power (db) by Octave Band | | | | | | | Sound Power (db) by Octave Band | | | | | | |
| | | | (2) | (3) | (4) | (5) | (6) | (7) | (7) | (2) | (3) | (4) | (5) | (6) | (7) | (7) | (2) | (3) | (4) | (5) | (6) | (7) | (7) | (2) | (3) | (4) | (5) | (6) | (7) | (7) |
| 5 | 75 | .028 | 35 | 23 | 17 | 17 | 16 | 17 | 51 | 47 | 44 | 42 | 40 | 37 | 51 | 48 | 46 | 45 | 44 | 42 | 51 | 51 | 49 | 50 | 52 | 50 | | | | |
| | 100 | .051 | 35 | 27 | 19 | 17 | 16 | 17 | 54 | 50 | 46 | 43 | 41 | 38 | 56 | 53 | 50 | 47 | 45 | 43 | 55 | 55 | 52 | 52 | 53 | 50 | | | | |
| | 200 | .192 | 49 | 44 | 39 | 36 | 31 | 21 | 64 | 60 | 52 | 48 | 45 | 39 | 65 | 63 | 56 | 51 | 49 | 45 | 67 | 66 | 61 | 57 | 55 | 52 | | | | |
| | 300 | .431 | 59 | 54 | 50 | 46 | 44 | 35 | 71 | 63 | 56 | 51 | 49 | 43 | 72 | 67 | 60 | 55 | 53 | 47 | 75 | 72 | 67 | 60 | 58 | 54 | | | | |
| | 350 | .554 | 62 | 57 | 53 | 50 | 48 | 39 | 74 | 65 | 58 | 53 | 51 | 44 | 75 | 67 | 61 | 56 | 54 | 48 | 76 | 74 | 68 | 62 | 59 | 55 | | | | |
| 6 | 110 | .020 | 36 | 26 | 19 | 16 | 16 | 18 | 51 | 48 | 46 | 43 | 40 | 37 | 53 | 52 | 49 | 47 | 45 | 42 | 55 | 54 | 52 | 53 | 53 | 51 | | | | |
| | 200 | .071 | 40 | 36 | 30 | 22 | 18 | 18 | 61 | 58 | 51 | 46 | 42 | 41 | 61 | 60 | 54 | 51 | 46 | 45 | 61 | 62 | 59 | 58 | 54 | 52 | | | | |
| | 300 | .149 | 47 | 45 | 40 | 35 | 28 | 21 | 65 | 60 | 53 | 50 | 44 | 42 | 65 | 65 | 58 | 53 | 48 | 47 | 66 | 70 | 65 | 60 | 56 | 54 | | | | |
| | 400 | .272 | 54 | 51 | 47 | 44 | 37 | 30 | 69 | 63 | 57 | 53 | 47 | 43 | 68 | 66 | 60 | 56 | 52 | 48 | 73 | 74 | 70 | 62 | 59 | 55 | | | | |
| | 500 | .395 | 59 | 58 | 53 | 51 | 45 | 38 | 72 | 66 | 59 | 55 | 49 | 45 | 71 | 68 | 63 | 58 | 53 | 49 | 74 | 75 | 70 | 64 | 58 | 56 | | | | |
| 7 | 140 | .010 | 35 | 23 | 17 | 17 | 16 | 17 | 50 | 50 | 49 | 47 | 41 | 37 | 52 | 52 | 52 | 46 | 43 | 43 | 53 | 56 | 55 | 58 | 54 | 52 | | | | |
| | 200 | .023 | 35 | 26 | 19 | 17 | 16 | 17 | 57 | 56 | 51 | 48 | 42 | 39 | 57 | 58 | 56 | 53 | 47 | 44 | 57 | 61 | 59 | 60 | 55 | 52 | | | | |
| | 400 | .093 | 48 | 42 | 37 | 37 | 24 | 20 | 66 | 60 | 54 | 53 | 46 | 42 | 65 | 65 | 59 | 56 | 50 | 47 | 67 | 74 | 68 | 63 | 57 | 54 | | | | |
| | 600 | .208 | 58 | 52 | 49 | 50 | 39 | 33 | 72 | 64 | 60 | 57 | 48 | 45 | 72 | 66 | 62 | 60 | 52 | 49 | 73 | 74 | 70 | 66 | 59 | 57 | | | | |
| | 700 | .261 | 59 | 54 | 51 | 54 | 43 | 37 | 71 | 65 | 61 | 59 | 50 | 46 | 72 | 68 | 64 | 61 | 54 | 50 | 74 | 74 | 69 | 66 | 60 | 57 | | | | |
| 8 | 185 | .009 | 36 | 23 | 18 | 19 | 18 | 18 | 52 | 53 | 53 | 51 | 43 | 38 | 55 | 54 | 56 | 56 | 49 | 44 | 58 | 59 | 57 | 61 | 57 | 53 | | | | |
| | 400 | .039 | 36 | 35 | 31 | 31 | 18 | 18 | 62 | 60 | 55 | 53 | 44 | 42 | 63 | 63 | 60 | 57 | 49 | 46 | 64 | 68 | 67 | 65 | 59 | 54 | | | | |
| | 600 | .083 | 49 | 44 | 41 | 44 | 30 | 23 | 67 | 62 | 58 | 56 | 47 | 45 | 69 | 67 | 62 | 60 | 51 | 49 | 70 | 75 | 71 | 67 | 59 | 56 | | | | |
| | 800 | .138 | 53 | 50 | 48 | 52 | 39 | 34 | 69 | 65 | 62 | 60 | 51 | 48 | 70 | 69 | 64 | 62 | 53 | 51 | 75 | 77 | 72 | 68 | 60 | 57 | | | | |
| | 1000 | .212 | 58 | 56 | 54 | 59 | 46 | 42 | 71 | 68 | 64 | 63 | 53 | 51 | 72 | 71 | 67 | 65 | 56 | 54 | 76 | 77 | 72 | 70 | 62 | 59 | | | | |
| 10 | 300 | .008 | 37 | 24 | 17 | 18 | 17 | 17 | 55 | 57 | 58 | 54 | 45 | 41 | 57 | 58 | 61 | 59 | 51 | 46 | 59 | 62 | 64 | 66 | 60 | 55 | | | | |
| | 500 | .013 | 37 | 31 | 25 | 24 | 18 | 17 | 59 | 60 | 58 | 54 | 46 | 43 | 61 | 66 | 64 | 61 | 51 | 48 | 62 | 69 | 72 | 70 | 61 | 56 | | | | |
| | 800 | .024 | 43 | 41 | 38 | 39 | 24 | 19 | 63 | 61 | 59 | 56 | 48 | 45 | 66 | 66 | 63 | 60 | 52 | 49 | 68 | 75 | 74 | 71 | 61 | 57 | | | | |
| | 1200 | .047 | 51 | 50 | 50 | 51 | 39 | 32 | 71 | 67 | 63 | 60 | 52 | 48 | 72 | 70 | 66 | 63 | 55 | 51 | 74 | 74 | 72 | 71 | 62 | 59 | | | | |
| | 1500 | .069 | 56 | 55 | 56 | 58 | 47 | 41 | 71 | 70 | 67 | 63 | 55 | 51 | 73 | 73 | 68 | 65 | 58 | 54 | 75 | 77 | 74 | 72 | 64 | 60 | | | | |
| 12 | 430 | .001 | 34 | 24 | 20 | 19 | 18 | 18 | 57 | 60 | 58 | 46 | 46 | 43 | 57 | 62 | 63 | 61 | 52 | 49 | 60 | 64 | 65 | 66 | 61 | 57 | | | | |
| | 800 | .003 | 38 | 30 | 32 | 22 | 18 | 18 | 61 | 59 | 59 | 55 | 46 | 45 | 64 | 66 | 64 | 61 | 52 | 50 | 67 | 75 | 74 | 71 | 62 | 58 | | | | |
| | 1200 | .005 | 43 | 41 | 43 | 36 | 29 | 21 | 64 | 62 | 60 | 55 | 48 | 46 | 67 | 65 | 64 | 61 | 52 | 50 | 70 | 75 | 74 | 71 | 62 | 58 | | | | |
| | 1800 | .007 | 51 | 49 | 56 | 49 | 43 | 37 | 69 | 65 | 65 | 57 | 51 | 48 | 72 | 69 | 68 | 62 | 55 | 52 | 76 | 75 | 74 | 71 | 63 | 59 | | | | |
| | 2300 | .009 | 56 | 54 | 62 | 56 | 51 | 45 | 70 | 68 | 67 | 60 | 55 | 51 | 73 | 71 | 70 | 64 | 58 | 54 | 77 | 77 | 75 | 71 | 65 | 61 | | | | |
| 14 | 600 | .004 | 38 | 30 | 22 | 24 | 24 | 21 | 61 | 60 | 59 | 56 | 48 | 44 | 66 | 65 | 63 | 61 | 53 | 50 | 65 | 69 | 67 | 66 | 61 | 59 | | | | |
| | 1000 | .006 | 39 | 32 | 31 | 24 | 22 | 20 | 61 | 61 | 61 | 56 | 49 | 45 | 66 | 67 | 67 | 62 | 53 | 50 | 69 | 76 | 74 | 73 | 64 | 59 | | | | |
| | 1600 | .011 | 44 | 42 | 45 | 35 | 32 | 23 | 65 | 63 | 61 | 56 | 51 | 47 | 68 | 67 | 67 | 62 | 56 | 53 | 72 | 76 | 74 | 72 | 64 | 59 | | | | |
| | 2400 | .024 | 50 | 51 | 58 | 48 | 45 | 37 | 70 | 69 | 64 | 59 | 53 | 49 | 74 | 70 | 68 | 68 | 62 | 57 | 78 | 76 | 74 | 70 | 65 | 61 | | | | |
| | 3100 | .036 | 56 | 57 | 68 | 56 | 53 | 45 | 71 | 73 | 70 | 63 | 57 | 52 | 75 | 75 | 71 | 65 | 60 | 56 | 80 | 79 | 76 | 71 | 67 | 62 | | | | |
| 16 | 780 | .005 | 43 | 32 | 25 | 29 | 28 | 23 | 61 | 60 | 59 | 57 | 50 | 44 | 64 | 63 | 63 | 61 | 55 | 51 | 65 | 66 | 65 | 64 | 61 | 59 | | | | |
| | 1600 | .016 | 46 | 39 | 39 | 30 | 29 | 24 | 63 | 61 | 60 | 57 | 50 | 44 | 68 | 65 | 65 | 62 | 55 | 50 | 74 | 76 | 74 | 71 | 66 | 60 | | | | |
| | 2400 | .041 | 52 | 48 | 52 | 42 | 38 | 30 | 70 | 65 | 61 | 57 | 52 | 47 | 72 | 68 | 66 | 62 | 57 | 52 | 76 | 76 | 74 | 71 | 66 | 61 | | | | |
| | 3600 | .089 | 59 | 57 | 71 | 54 | 51 | 44 | 73 | 73 | 66 | 60 | 56 | 51 | 78 | 73 | 68 | 64 | 60 | 56 | 81 | 78 | 74 | 71 | 67 | 63 | | | | |
| | 4200 | .120 | 64 | 61 | 72 | 59 | 56 | 49 | 73 | 76 | 71 | 63 | 59 | 54 | 77 | 78 | 71 | 65 | 61 | 57 | 82 | 81 | 75 | 71 | 68 | 64 | | | | |
| 18 | 1100 | .001 | 40 | 32 | 25 | 21 | 20 | 20 | 61 | 60 | 57 | 58 | 51 | 47 | 62 | 63 | 61 | 61 | 55 | 52 | 65 | 68 | 66 | 66 | 61 | 59 | | | | |
| | 2300 | .006 | 57 | 51 | 46 | 39 | 36 | 33 | 67 | 64 | 59 | 58 | 50 | 48 | 71 | 70 | 63 | 61 | 55 | 53 | 73 | 77 | 73 | 70 | 66 | 61 | | | | |
| | 3600 | .024 | 64 | 60 | 59 | 50 | 45 | 37 | 72 | 68 | 63 | 59 | 54 | 51 | 75 | 72 | 65 | 62 | 57 | 54 | 79 | 79 | 74 | 70 | 66 | 62 | | | | |
| | 4500 | .038 | 69 | 65 | 69 | 57 | 52 | 45 | 78 | 73 | 66 | 62 | 58 | 54 | 79 | 75 | 69 | 65 | 60 | 57 | 81 | 80 | 75 | 70 | 66 | 62 | | | | |
| | 5500 | .056 | 74 | 70 | 77 | 62 | 57 | 52 | 82 | 77 | 70 | 65 | 61 | 57 | 82 | 79 | 71 | 67 | 63 | 59 | 83 | 82 | 76 | 72 | 67 | 64 | | | | |
| 24 | 1480 | .000 | 43 | 36 | 31 | 27 | 25 | 22 | 66 | 64 | 61 | 60 | 51 | 49 | 68 | 69 | 65 | 65 | 57 | 54 | 68 | 72 | 71 | 70 | 64 | 62 | | | | |
| | 3200 | .040 | 58 | 53 | 52 | 43 | 35 | 28 | 68 | 65 | 63 | 60 | 52 | 51 | 71 | 69 | 67 | 65 | 57 | 56 | 76 | 78 | 76 | 74 | 68 | 65 | | | | |
| | 4800 | .090 | 69 | 64 | 64 | 55 | 49 | 43 | 74 | 70 | 66 | 62 | 56 | 54 | 76 | 72 | 69 | 65 | 59 | 59 | 80 | 79 | 76 | 74 | 68 | 66 | | | | |
| | 6000 | .140 | 74 | 70 | 72 | 62 | 56 | 52 | 79 | 74 | 68 | 65 | 59 | 57 | 80 | 76 | 71 | 67 | 62 | 60 | 82 | 80 | 78 | 74 | 69 | 67 | | | | |
| | 7300 | .200 | 77 | 74 | 83 | 67 | 59 | 53 | 80 | 77 | 72 | 67 | 62 | 58 | 85 | 79 | 74 | 74 | 65 | 61 | 86 | 84 | 86 | 76 | 74 | 69 | | | | |

- NOTES:**
1. Based on tests conducted in accordance with AHRI Standard 880-2008.
 2. ΔP_s static pressure difference from inlet to discharge.
 3. ΔP_s is the minimum pressure required to deliver CFM shown with primary damper in wide open position.
 4. Dash (—) indicates db level less than 10.



A Participating Member
in the AHRI 880
Certification Program

Sound Data (Sound Power by Octave Band)

Radiated Sound Power

| Inlet Size (Inches) | CFM | Minimum ΔP_s | | | | | | | 1.0" ΔP_s | | | | | | | 1.5" ΔP_s | | | | | | | 3.0" ΔP_s | | | | | | |
|---------------------|------|---------------------------------|-----|-----|-----|-----|-----|-----|---------------------------------|-----|-----|-----|-----|-----|-----|---------------------------------|-----|-----|-----|-----|-----|-----|---------------------------------|-----|-----|-----|----|--|--|
| | | Sound Power (db) by Octave Band | | | | | | | Sound Power (db) by Octave Band | | | | | | | Sound Power (db) by Octave Band | | | | | | | Sound Power (db) by Octave Band | | | | | | |
| | | ΔP_s | (2) | (3) | (4) | (5) | (6) | (7) | (2) | (3) | (4) | (5) | (6) | (7) | (2) | (3) | (4) | (5) | (6) | (7) | (2) | (3) | (4) | (5) | (6) | (7) | | | |
| 5 | 75 | .028 | 39 | 31 | 23 | 21 | 21 | 21 | 53 | 49 | 48 | 44 | 43 | 41 | 54 | 55 | 52 | 48 | 48 | 47 | 56 | 57 | 55 | 55 | 55 | 56 | | | |
| | 100 | .051 | 41 | 30 | 25 | 21 | 21 | 21 | 55 | 50 | 49 | 44 | 43 | 41 | 57 | 55 | 53 | 48 | 48 | 47 | 59 | 62 | 59 | 56 | 56 | 56 | | | |
| | 200 | .192 | 42 | 36 | 36 | 28 | 23 | 22 | 61 | 52 | 50 | 45 | 44 | 42 | 64 | 56 | 54 | 49 | 48 | 47 | 67 | 66 | 62 | 56 | 55 | 56 | | | |
| | 300 | .431 | 45 | 45 | 49 | 38 | 34 | 26 | 63 | 55 | 53 | 47 | 46 | 43 | 67 | 58 | 55 | 51 | 50 | 48 | 71 | 63 | 60 | 57 | 56 | 56 | | | |
| | 350 | .554 | 52 | 49 | 56 | 44 | 42 | 34 | 65 | 57 | 55 | 49 | 47 | 45 | 69 | 61 | 58 | 52 | 51 | 49 | 74 | 67 | 63 | 59 | 57 | 56 | | | |
| 6 | 110 | .020 | 40 | 29 | 20 | 19 | 20 | 21 | 45 | 42 | 39 | 41 | 43 | 40 | 46 | 43 | 41 | 45 | 47 | 45 | 45 | 45 | 42 | 49 | 54 | 54 | | | |
| | 200 | .071 | 39 | 34 | 24 | 22 | 20 | 20 | 53 | 51 | 43 | 43 | 44 | 40 | 54 | 52 | 45 | 46 | 48 | 46 | 53 | 52 | 47 | 50 | 55 | 54 | | | |
| | 300 | .149 | 43 | 39 | 33 | 30 | 27 | 23 | 58 | 55 | 46 | 44 | 46 | 42 | 60 | 56 | 48 | 47 | 50 | 47 | 60 | 57 | 52 | 52 | 55 | 55 | | | |
| | 400 | .272 | 48 | 44 | 41 | 40 | 37 | 28 | 60 | 55 | 47 | 46 | 47 | 43 | 63 | 58 | 52 | 48 | 50 | 47 | 64 | 61 | 56 | 53 | 56 | 56 | | | |
| | 500 | .395 | 52 | 50 | 45 | 45 | 43 | 37 | 64 | 56 | 50 | 47 | 48 | 44 | 65 | 59 | 52 | 49 | 51 | 49 | 67 | 63 | 58 | 54 | 56 | 57 | | | |
| 7 | 140 | .010 | 41 | 32 | 23 | 22 | 23 | 22 | 45 | 39 | 37 | 35 | 35 | 34 | 47 | 40 | 39 | 41 | 41 | 41 | 40 | 46 | 44 | 43 | 47 | 50 | 49 | | |
| | 200 | .023 | 41 | 30 | 23 | 22 | 21 | 22 | 50 | 44 | 40 | 37 | 38 | 35 | 52 | 46 | 43 | 41 | 42 | 41 | 51 | 48 | 46 | 48 | 50 | 49 | | | |
| | 400 | .093 | 44 | 33 | 30 | 28 | 24 | 22 | 59 | 51 | 45 | 42 | 41 | 38 | 61 | 54 | 49 | 45 | 44 | 43 | 63 | 59 | 56 | 50 | 50 | 49 | | | |
| | 600 | .208 | 50 | 42 | 42 | 39 | 33 | 27 | 64 | 53 | 49 | 45 | 43 | 41 | 66 | 56 | 52 | 48 | 47 | 45 | 68 | 62 | 59 | 53 | 53 | 51 | | | |
| | 700 | .261 | 54 | 45 | 44 | 42 | 38 | 31 | 66 | 56 | 50 | 45 | 44 | 42 | 67 | 58 | 53 | 48 | 47 | 45 | 70 | 63 | 59 | 54 | 54 | 52 | | | |
| 8 | 185 | .009 | 39 | 27 | 18 | 17 | 20 | 21 | 50 | 43 | 41 | 36 | 39 | 36 | 50 | 44 | 42 | 40 | 43 | 41 | 52 | 49 | 46 | 46 | 48 | 49 | | | |
| | 400 | .039 | 39 | 28 | 23 | 20 | 20 | 21 | 57 | 51 | 45 | 38 | 37 | 35 | 58 | 55 | 50 | 43 | 41 | 40 | 60 | 57 | 56 | 50 | 48 | 49 | | | |
| | 600 | .083 | 43 | 34 | 32 | 29 | 25 | 22 | 60 | 53 | 49 | 42 | 40 | 36 | 62 | 58 | 53 | 44 | 43 | 40 | 64 | 62 | 61 | 53 | 49 | 49 | | | |
| | 800 | .138 | 48 | 42 | 41 | 39 | 33 | 27 | 62 | 55 | 51 | 45 | 43 | 38 | 64 | 59 | 55 | 47 | 46 | 42 | 67 | 65 | 62 | 54 | 51 | 49 | | | |
| | 1000 | .212 | 52 | 46 | 46 | 43 | 40 | 34 | 65 | 57 | 53 | 47 | 45 | 40 | 67 | 60 | 57 | 50 | 48 | 44 | 71 | 66 | 63 | 56 | 53 | 50 | | | |
| 10 | 300 | .008 | 38 | 28 | 22 | 18 | 20 | 22 | 53 | 50 | 46 | 40 | 40 | 39 | 54 | 51 | 49 | 44 | 44 | 44 | 58 | 54 | 51 | 50 | 52 | 52 | | | |
| | 500 | .013 | 37 | 29 | 24 | 18 | 19 | 22 | 56 | 51 | 47 | 41 | 41 | 40 | 59 | 56 | 51 | 44 | 44 | 44 | 61 | 60 | 59 | 52 | 52 | 52 | | | |
| | 800 | .024 | 42 | 33 | 31 | 26 | 22 | 21 | 60 | 53 | 49 | 44 | 42 | 40 | 64 | 58 | 54 | 45 | 45 | 45 | 64 | 64 | 63 | 55 | 52 | 51 | | | |
| | 1200 | .047 | 50 | 42 | 42 | 39 | 31 | 25 | 66 | 57 | 52 | 48 | 46 | 42 | 67 | 59 | 55 | 50 | 50 | 46 | 69 | 65 | 61 | 57 | 54 | 52 | | | |
| | 1500 | .069 | 52 | 47 | 48 | 45 | 39 | 32 | 67 | 60 | 55 | 49 | 47 | 43 | 69 | 65 | 57 | 51 | 51 | 47 | 73 | 66 | 62 | 59 | 57 | 53 | | | |
| 12 | 430 | .001 | 39 | 31 | 23 | 21 | 21 | 21 | 52 | 49 | 48 | 44 | 43 | 41 | 53 | 54 | 51 | 48 | 48 | 47 | 55 | 55 | 54 | 55 | 55 | 56 | | | |
| | 800 | .003 | 41 | 31 | 26 | 22 | 20 | 21 | 56 | 50 | 49 | 44 | 43 | 41 | 59 | 55 | 53 | 48 | 48 | 47 | 61 | 63 | 60 | 56 | 56 | 56 | | | |
| | 1200 | .005 | 42 | 35 | 34 | 27 | 24 | 22 | 60 | 52 | 50 | 45 | 44 | 42 | 63 | 56 | 54 | 49 | 48 | 47 | 66 | 65 | 62 | 56 | 56 | 56 | | | |
| | 1800 | .007 | 45 | 45 | 50 | 38 | 34 | 26 | 64 | 55 | 53 | 47 | 46 | 43 | 68 | 58 | 55 | 51 | 50 | 48 | 72 | 63 | 61 | 57 | 56 | 57 | | | |
| | 2300 | .009 | 52 | 49 | 56 | 44 | 42 | 34 | 65 | 57 | 55 | 49 | 47 | 45 | 69 | 61 | 58 | 52 | 51 | 49 | 74 | 66 | 63 | 59 | 57 | 58 | | | |
| 14 | 600 | .004 | 38 | 24 | 17 | 17 | 20 | 21 | 54 | 51 | 46 | 39 | 33 | 32 | 57 | 54 | 50 | 44 | 38 | 37 | 61 | 59 | 56 | 49 | 46 | 46 | | | |
| | 1000 | .006 | 38 | 28 | 23 | 17 | 19 | 20 | 55 | 51 | 47 | 41 | 38 | 34 | 58 | 56 | 52 | 46 | 41 | 39 | 63 | 63 | 61 | 54 | 49 | 47 | | | |
| | 1600 | .011 | 39 | 37 | 36 | 25 | 23 | 22 | 60 | 53 | 49 | 44 | 40 | 36 | 63 | 57 | 54 | 47 | 45 | 42 | 67 | 65 | 62 | 57 | 51 | 49 | | | |
| | 2400 | .024 | 45 | 51 | 52 | 38 | 34 | 28 | 66 | 57 | 53 | 46 | 42 | 38 | 70 | 60 | 55 | 49 | 47 | 43 | 73 | 66 | 61 | 56 | 53 | 51 | | | |
| | 3100 | .036 | 52 | 56 | 57 | 44 | 42 | 36 | 66 | 62 | 60 | 49 | 45 | 42 | 70 | 64 | 59 | 51 | 47 | 45 | 76 | 69 | 63 | 57 | 54 | 51 | | | |
| 16 | 780 | .005 | 41 | 31 | 24 | 21 | 20 | 22 | 54 | 52 | 47 | 39 | 30 | 28 | 57 | 55 | 51 | 43 | 36 | 35 | 60 | 58 | 54 | 47 | 44 | 44 | | | |
| | 1600 | .016 | 42 | 38 | 31 | 22 | 21 | 21 | 59 | 53 | 47 | 41 | 33 | 30 | 62 | 57 | 53 | 45 | 37 | 35 | 67 | 66 | 61 | 54 | 46 | 45 | | | |
| | 2400 | .041 | 45 | 48 | 42 | 29 | 25 | 23 | 64 | 55 | 49 | 43 | 36 | 33 | 67 | 59 | 54 | 47 | 40 | 37 | 71 | 67 | 62 | 56 | 47 | 45 | | | |
| | 3600 | .089 | 54 | 58 | 57 | 42 | 36 | 29 | 67 | 61 | 55 | 46 | 40 | 36 | 70 | 61 | 56 | 49 | 44 | 41 | 74 | 67 | 60 | 55 | 50 | 47 | | | |
| | 4200 | .120 | 57 | 56 | 59 | 46 | 41 | 35 | 66 | 65 | 61 | 48 | 42 | 38 | 70 | 65 | 61 | 50 | 45 | 41 | 76 | 70 | 62 | 56 | 51 | 49 | | | |
| 18 | 1100 | .001 | 44 | 31 | 26 | 22 | 20 | 20 | 58 | 50 | 47 | 50 | 48 | 42 | 59 | 53 | 50 | 49 | 47 | 46 | 62 | 57 | 57 | 56 | 53 | 52 | | | |
| | 2300 | .006 | 47 | 44 | 33 | 22 | 20 | 21 | 63 | 54 | 48 | 43 | 40 | 37 | 66 | 58 | 53 | 48 | 45 | 44 | 70 | 66 | 64 | 59 | 56 | 53 | | | |
| | 3600 | .024 | 55 | 60 | 51 | 33 | 26 | 24 | 68 | 57 | 51 | 44 | 41 | 38 | 71 | 61 | 55 | 48 | 44 | 42 | 75 | 68 | 64 | 59 | 54 | 52 | | | |
| | 4500 | .038 | 61 | 66 | 62 | 41 | 31 | 26 | 72 | 60 | 55 | 48 | 44 | 40 | 73 | 63 | 56 | 50 | 46 | 43 | 77 | 69 | 63 | 59 | 52 | 52 | | | |
| | 5500 | .056 | 63 | 63 | 66 | 45 | 37 | 31 | 75 | 66 | 59 | 50 | 46 | 42 | 76 | 66 | 60 | 52 | 50 | 46 | 80 | 70 | 64 | 58 | 53 | 52 | | | |
| 24 | 1480 | .000 | 42 | 30 | 21 | 19 | 20 | 21 | 62 | 58 | 57 | 56 | 54 | 53 | 63 | 63 | 62 | 60 | 60 | 59 | 68 | 71 | 70 | 67 | 69 | 67 | | | |
| | 3200 | .040 | 50 | 54 | 42 | 31 | 23 | 23 | 66 | 59 | 56 | 53 | 53 | 51 | 69 | 64 | 61 | 58 | 59 | 57 | 73 | 72 | 72 | 68 | 69 | 66 | | | |
| | 4800 | .090 | 60 | 67 | 55 | 42 | 35 | 34 | 70 | 62 | 57 | 53 | 52 | 50 | 72 | 65 | 61 | 58 | 57 | 56 | 77 | 73 | 70 | 67 | 67 | 65 | | | |
| | 6000 | .140 | 65 | 70 | 63 | 49 | 42 | 40 | 73 | 65 | 59 | 54 | 52 | 50 | 75 | 67 | 63 | 58 | 56 | 54 | 80 | 74 | 69 | 66 | 65 | 64 | | | |
| | 7300 | .200 | 65 | 66 | 71 | 53 | 43 | 40 | 75 | 68 | 61 | 54 | 51 | 47 | 79 | 71 | 65 | 58 | 55 | 52 | 80 | 74 | 72 | 65 | 63 | 62 | | | |

- NOTES: 1. Based on tests conducted in accordance with AHRI Standard 880-2008.
 2. ΔP_s static pressure difference from inlet to discharge.
 3. ΔP_s is the minimum pressure required to deliver CFM shown with primary damper in wide open position.
 4. Dash (—) indicates db level less than 10.



A Participating Member in the AHRI 880 Certification Program

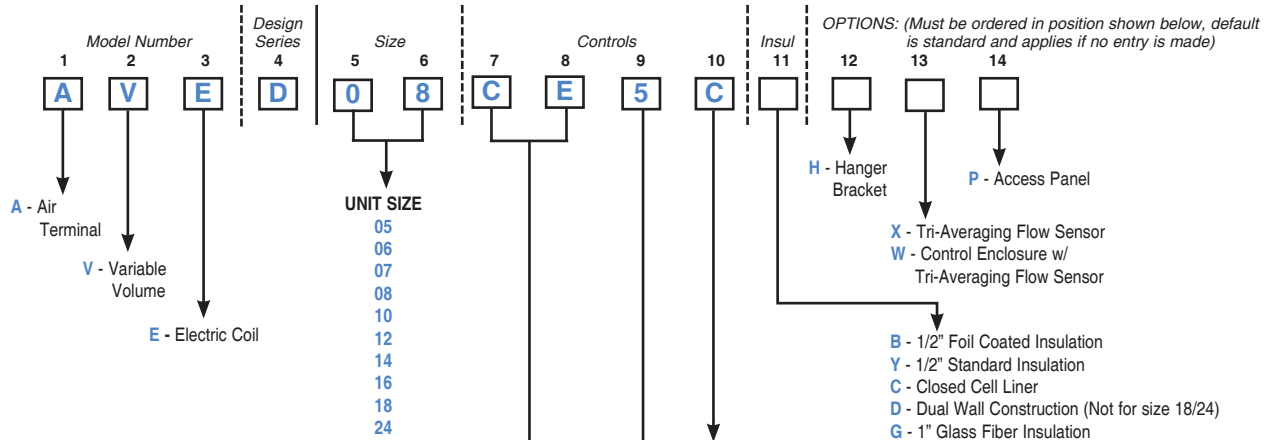

CONTROL TYPE

- CA - Pneumatic Actuator with Mechanical Max./Min. Stops by Carnes
- CM - Pneumatic Actuator by Carnes
- CE - Pneumatic Actuator by Carnes, Reset Controller by Carnes
- CX - Pneumatic Actuator by Carnes (Multi-function) Reset Controller by Carnes
- ER - Electric Actuator with Reheat Switch by Carnes (Enclosure Included)
- EK - Electric Actuator with (2) Reheat Switches by Carnes (Enclosure Included)
- ET - Analog Electronic Velocity Controller with Integral Damper Actuator (Enclosure Included)
- DD - SimplyVAV, DDC by Carnes for Staged Heat
- DM - SimplyVAV, DDC by Carnes for SCR Heat
- DO - DDC Provided by Others, Mounted and Wired by Carnes, w/Carnes Inlet Sensor w/ 3/8" Damper Shaft, w/Enclosure
- DE - No Damper Controls. Enclosure with Carnes Inlet Sensor, w/Bare 3/8" Damper Shaft
- MA - Manual Damper by Carnes
- NS - No Damper Controls, w/Carnes Inlet Sensor, w/bare 3/8" Damper Shaft (No Enclosure)

CONTROLS, DAMPERS AND COIL ARRANGEMENTS

- *1 - Normally Open - Right Hand Controls (All Electric/Electronic/Manual Control Types/DO, DE, NS) (All Pneumatic Control Types for Reverse Acting Thermostat)
- *2 - Normally Open - Left Hand Controls (All Electric/Electronic/Manual Control Types/DO, DE, NS) (All Pneumatic Control Types for Reverse Acting Thermostat)
- 3 - Normally Closed - Right Hand Controls (All Pneumatic Control Types for Direct Acting Thermostat)
- 4 - Normally Closed - Left Hand Controls (All Pneumatic Control Types for Direct Acting Thermostat)
- 5 - Normally Open - Right Hand Controls (All Pneumatic Control Types for Direct Acting Thermostat)
- 6 - Normally Open - Left Hand Controls (All Pneumatic Control Types for Direct Acting Thermostat)
- 7 - Normally Closed - Right Hand Controls (All Pneumatic Control Types for Reverse Acting Thermostat)
- 8 - Normally Closed - Left Hand Controls (All Pneumatic Control Types for Reverse Acting Thermostat)

* Electric, Electronic and DDC Units **DO NOT** fail open. '1' or '2' is used for Right or Left Hand Only. Electric/Electronic Units are shipped with the Damper in the Open Position.

NOTE: Hand of controls is determined by facing the averaging flow sensor (inlet of the unit) with the supply air hitting the back of your head.

▼ **Electric Thermostat**

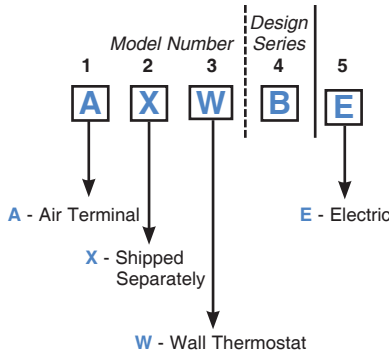

A Carnes Electric Thermostat **must be ordered** with the Electric ER and EK Control Options.

Power Transformers are included with the Electric Heater.

▼ **Electronic Thermostat**

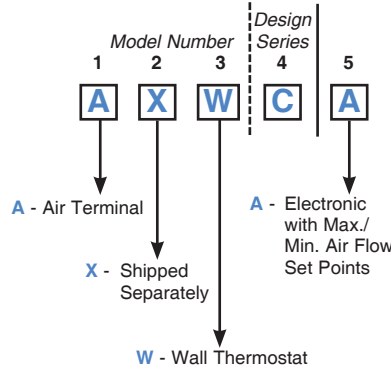

A Carnes Electronic Thermostat **must be ordered** with the ET Electronic Control Option.

▼ **Direct Digital Control (DD/DC/DM)**

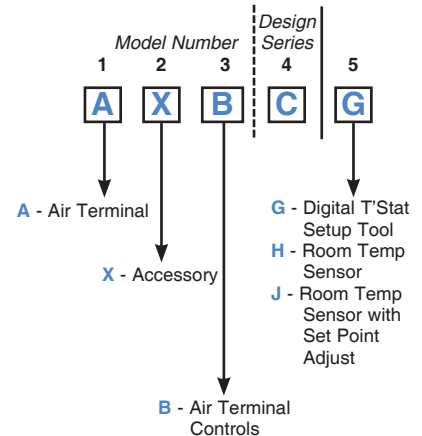

LEFT HAND UNIT SHOWN
RIGHT HAND AVAILABLE

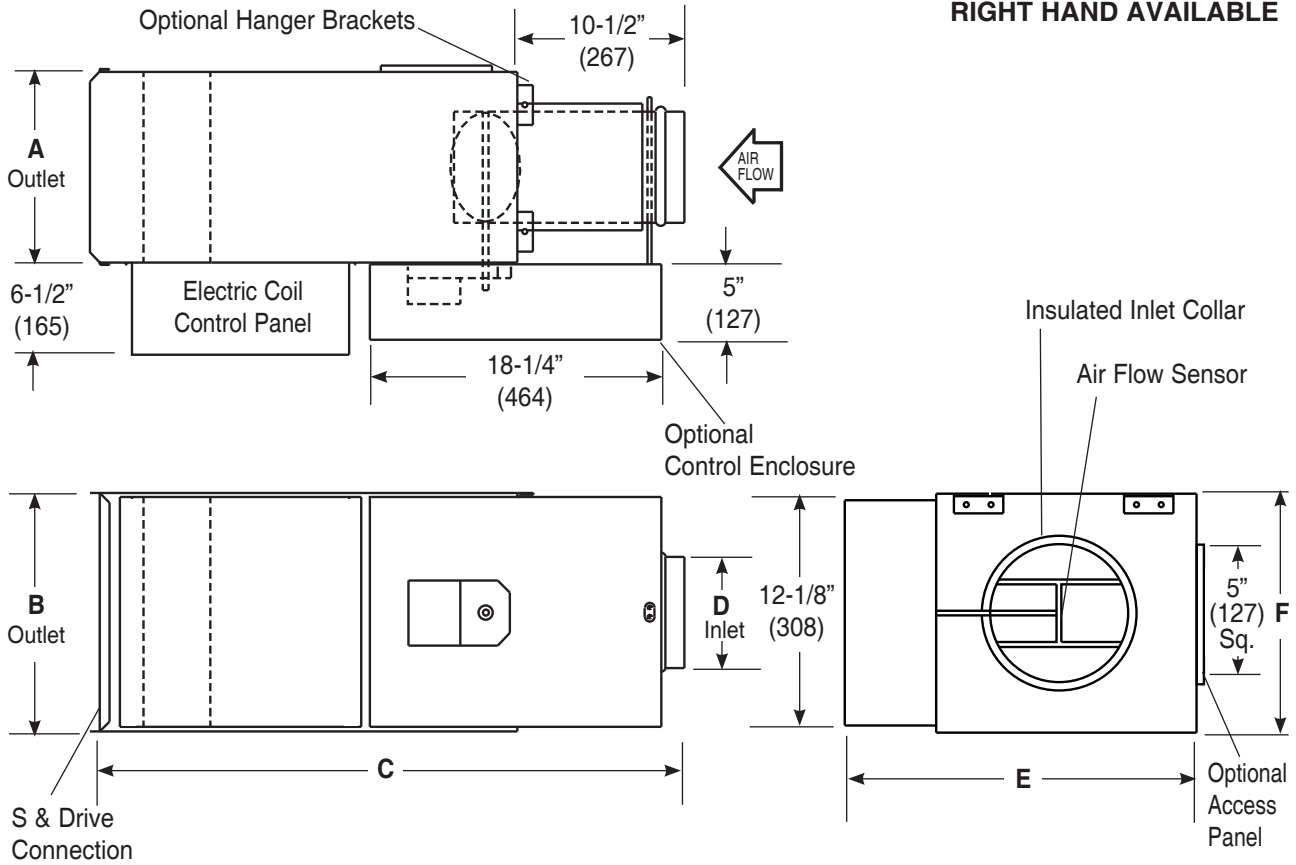

| DIMENSIONS LISTED IN INCHES (Metric In Millimeters) | | | | | | | | |
|-----------------------------------------------------|--------------------|-------------|-----------------|------------------|--------------------------------|-----------------|-----------------|---|
| Unit Size | CFM (L/s) Range | Outlet | | C | Inlet | | E | F |
| | | A | B | | D | | | |
| 05 | 0-350 (0-165) | 12 (305) | 8 (203) | 44-3/8 (1127) | 4-7/8 (124) | 18-1/2 (470) | 8-1/8 (206) | |
| 06 | 0-500 (0-236) | 12 (305) | 8 (203) | 44-3/8 (1127) | 5-7/8 (149) | 18-1/2 (470) | 8-1/8 (206) | |
| 07 | 0-700 (0-330) | 12 (305) | 10 (254) | 44-3/8 (1127) | 6-7/8 (175) | 18-1/2 (470) | 10-1/8 (257) | |
| 08 | 0-1000 (0-472) | 12 (305) | 10 (254) | 44-3/8 (1127) | 7-7/8 (200) | 18-1/2 (470) | 10-1/8 (257) | |
| 10 | 0-1500 (0-708) | 14 (356) | 12-1/2 (318) | 44-3/8 (1127) | 9-7/8 (251) | 20-1/2 (521) | 12-5/8 (321) | |
| 12 | 0-2300 (0-1085) | 16 (406) | 15 (381) | 44-3/8 (1127) | 11-7/8 (302) | 22-1/2 (572) | 15-1/8 (384) | |
| 14 | 0-3100 (0-1463) | 20 (508) | 17-1/2 (445) | 44-3/8 (1127) | 13-7/8 (352) | 26-1/2 (673) | 17-5/8 (448) | |
| 16 | 0-4200 (0-1982) | 24 (610) | 18 (457) | 44-3/8 (1127) | 15-7/8 (403) | 30-1/2 (775) | 18-1/8 (460) | |
| 18 | 0-5500 (0-2596) | 32 (813) | 17-1/2 (445) | 44-3/8 (1127) | 15-7/8 x 17-7/8 (403 x 454) | 38-1/2 (978) | 17-5/8 (448) | |
| 24 | 0-7300 (0-3445) | 32 (813) | 17-1/2 (445) | 44-3/8 (1127) | 15-7/8 x 23-7/8 (403 x 607) | 38-1/2 (978) | 17-5/8 (448) | |