

### ▼ Model ADCD

The **Carnes Model ADCD** dual duct VAV unit contains two valves providing low pressure drop and low sound level. Hot and cold duct valves are independently controlled. Throttling valves are installed in an attenuator mixing section for low noise and temperature mixing. Pressure independent reset volume controllers accurately control the hot and cold duct air flows.

A common thermostat controls the individual reset volume controllers. Selections of proper control-

lers and pneumatic devices allow sequences of operation for constant discharge volume control. (See *ADCC design for adjustable mixing or no mixing applications*).

Hot and cold throttling valves can be factory set for normally open or normally closed configurations, compatible with direct or reverse acting thermostats.

A wide range of available control sequences makes the Carnes dual inlet VAV unit acceptable to most energy saving system design.

#### *Features Include:*

- Air flow capacities from full shut-off to 4,200 CFM (0,-3,000 FPM for each unit size).
- Open-end discharge units are provided with slip and drive connections for easy installation.
- Thermally and acoustically insulated casing meets **UL** and **NFPA** standards.
- Hot and cold throttling valves are independently controlled.
- Low leakage damper design.
- Integral attenuator/temperature mixing section.
- Tri-Averaging type air flow sensor at unit inlets.
- Tri-Averaging type discharge sensor assembly for constant volume applications.
- Optional pressure independent and pressure dependent controls.
- Pressure independent pneumatic constant volume control.
- Pneumatic pressure independent reset constant volume control accurately control hot and cold air flows.
- Optional controls enclosure.
- Optional foil coated internal insulation.
- Optional fiber-free liner.
- Optional hanger brackets (Sizes 0505-1010 only).
- **AHRI** certified product.

#### *Available Modules:*

- Basic Control Unit — **Model ADCD**
- Sound Attenuator — **Model AXA**



A Participating Member  
in the AHRI 880  
Certification Program

**ADCD**

Discharge and Radiated (NC) Noise Criteria

Inlet Size (Inches)	CFM	Minimum Pressure Drop (Damper Full Open)				Min. $\Delta P_s$ (Damper Full Open)			1.0" $\Delta P_s$			1.5" $\Delta P_s$			3.0" $\Delta P_s$						
		Min. $\Delta P_s$		Min. $\Delta P_t$		$\Delta P_t$	Discharge NC Unit w/Atten.	Rad. NC	$\Delta P_t$	Discharge NC Unit w/Atten.	Rad. NC	$\Delta P_t$	Discharge NC Unit w/Atten.	Rad. NC	$\Delta P_t$	Discharge NC Unit w/Atten.	Rad. NC				
		Base Unit	With Atten.	Base Unit	With Atten.																
5	75	.04	.04	.06	.06	.06	—	—	1.02	—	—	1.52	—	—	3.02	—	—	13			
	100	.06	.07	.10	.10	.10	—	—	1.04	—	—	1.54	—	—	3.04	—	—	14			
	200	.21	.23	.35	.38	.35	—	—	1.14	—	—	1.7	10	—	17	3.14	16	—	21		
	300	.43	.47	.75	.80	.75	—	—	1.33	14	—	22	1.83	18	—	23	3.33	23	11	25	
	350	.57	.62	1.01	1.06	1.01	10	—	15	1.44	17	—	24	1.94	20	—	24	3.44	25	14	27
6	110	.03	.05	.05	.07	.05	—	—	1.02	—	—	1.52	—	—	3.02	—	—	12			
	200	.10	.14	.17	.21	.17	—	—	1.07	—	—	1.57	—	—	14	3.07	13	—	19		
	300	.23	.29	.38	.44	.38	—	—	1.15	13	—	15	1.65	16	—	19	3.15	20	10	23	
	400	.41	.47	.67	.74	.67	10	—	11	1.27	17	—	19	1.77	20	—	22	3.27	25	14	26
	500	.63	.69	1.05	1.11	1.05	14	—	16	1.42	21	—	24	1.92	24	13	26	3.42	28	18	30
7	140	.02	.03	.04	.05	.04	—	—	1.02	—	—	1.52	—	—	10	3.02	10	—	16		
	200	.05	.06	.08	.10	.08	—	—	1.03	—	—	1.53	10	—	13	3.03	15	11	20		
	400	.20	.28	.33	.41	.33	—	—	1.14	17	—	18	1.64	20	13	21	3.14	24	18	26	
	600	.47	.67	.77	.98	.77	15	—	15	1.30	22	15	24	1.80	25	19	26	3.30	31	24	31
	700	.65	.94	1.07	1.35	1.07	19	—	18	1.41	24	18	26	1.91	28	22	28	3.41	34	27	33
8	185	.03	.04	.04	.05	.04	—	—	1.02	—	—	1.52	—	—	14	3.02	15	—	20		
	400	.13	.20	.21	.27	.21	—	—	1.07	16	—	19	1.57	19	10	22	3.07	25	16	27	
	600	.31	.47	.47	.63	.47	10	—	14	1.16	22	14	23	1.66	25	17	27	3.16	31	22	32
	800	.57	.85	.86	1.14	.86	16	10	19	1.29	24	17	30	1.79	28	19	31	3.29	35	25	35
	1000	.91	1.36	1.36	1.81	1.36	21	17	23	1.45	28	20	32	1.95	31	23	35	3.45	38	29	39
10	300	.02	.02	.03	.04	.03	—	—	1.02	—	—	1.52	12	—	16	3.02	18	11	23		
	500	.04	.06	.09	.11	.09	—	—	1.04	14	—	16	1.54	17	—	21	3.04	25	16	28	
	800	.11	.18	.22	.29	.22	—	—	1.11	19	—	22	1.61	23	11	25	3.11	31	19	32	
	1200	.24	.44	.49	.70	.49	13	—	17	1.25	24	13	28	1.75	29	17	31	3.25	36	23	36
	1500	.37	.73	.77	1.13	.77	19	—	20	1.40	27	15	32	1.90	31	19	35	3.40	40	27	40
12	430	.01	.02	.03	.04	.03	—	—	1.02	12	—	15	1.52	15	—	19	3.02	23	16	25	
	800	.06	.08	.11	.14	.11	—	—	1.05	17	—	22	1.55	21	14	24	3.05	29	21	31	
	1200	.14	.21	.26	.32	.26	—	—	1.12	21	15	28	1.62	25	19	32	3.12	34	27	37	
	1800	.33	.51	.60	.78	.60	15	11	21	1.27	25	20	35	1.77	30	26	39	3.27	38	33	45
	2300	.56	.88	1.00	1.31	1.00	22	19	27	1.43	28	24	39	1.93	33	30	43	3.43	41	37	49
14	600	.02	.02	.03	.04	.03	—	—	1.02	10	—	15	1.52	15	11	20	3.02	24	21	27	
	1000	.04	.05	.09	.10	.09	—	—	1.05	14	—	20	1.55	19	15	24	3.05	29	24	31	
	1600	.11	.14	.22	.26	.22	—	—	1.12	19	14	24	1.62	24	19	28	3.12	34	29	36	
	2400	.23	.32	.50	.58	.50	—	—	1.26	23	19	30	1.76	29	24	33	3.26	37	33	41	
	3100	.38	.54	.82	.98	.82	15	12	26	1.44	27	23	32	1.94	31	27	37	3.44	41	36	45
16	780	.04	.04	.05	.06	.05	—	—	1.02	11	—	21	1.52	16	11	24	3.02	24	19	30	
	1600	.18	.20	.24	.26	.24	—	—	1.07	18	17	27	1.57	23	22	30	3.07	31	23	37	
	2400	.42	.47	.57	.62	.57	11	10	23	1.15	23	31	1.65	28	27	34	3.15	36	35	41	
	3600	1.00	1.15	1.33	1.48	1.33	22	23	35	1.33	30	28	34	1.83	33	33	37	3.33	43	41	46
	4200	1.38	1.60	1.83	2.05	1.83	26	28	39	1.45	31	31	35	1.95	36	35	39	3.45	45	43	48

- NOTES:**
1.  $\Delta P_s$  static pressure difference from inlet to discharge.
  2.  $\Delta P_s$  is the minimum pressure required to deliver CFM shown with the primary damper in wide open position.
  3.  $\Delta P_t$  is the total pressure difference from inlet to discharge.
  4. Dash (—) indicates NC level less than 10.

NC levels are derived from tests conducted in accordance with AHRI Standard 880-2008 and are calculated in accordance with AHRI Standard 885-2008 as application data based on the following:

- Discharge NC levels are based on —
- a) 5 foot rectangular duct lined with 1" fiberglass insulation.
  - b) 5 foot lined flex duct (8" diameter).
  - c) Flow division.
  - d) Space effect factor (2400 ft<sup>3</sup>) at 5 feet from outlet.
  - e) End reflection.
  - f) Environmental adjustment factor.

- Radiated NC levels are based on—
- a) Plenum / ceiling effect - 5/8" mineral fiber tile, 35 lb / ft<sup>3</sup> - 3 foot plenum.
  - b) Environmental adjustment factor.

NC is not part of the AHRI 880 Certification Program.

**Sound Data (Sound Power by Octave Band)**

**Discharge Sound Power**

Inlet Size (Inches)	CFM	Minimum $\Delta P_s$							1.0" $\Delta P_s$							1.5" $\Delta P_s$							3.0" $\Delta P_s$							
		$\Delta P_s$	Sound Power (db) by Octave Band							Sound Power (db) by Octave Band							Sound Power (db) by Octave Band							Sound Power (db) by Octave Band						
			(2)	(3)	(4)	(5)	(6)	(7)	(7)	(2)	(3)	(4)	(5)	(6)	(7)	(7)	(2)	(3)	(4)	(5)	(6)	(7)	(7)	(2)	(3)	(4)	(5)	(6)	(7)	(7)
5	140	.09	41	35	33	30	30	27	46	42	45	42	42	39	48	44	47	45	44	42	50	48	51	49	47	47				
	200	.18	45	43	41	37	38	35	51	47	49	45	46	44	53	49	51	47	48	47	55	53	55	52	51	53				
	250	.29	48	47	45	41	43	39	54	50	52	46	49	48	58	54	56	51	53	53	58	56	58	53	54	56				
	300	.42	51	51	49	45	47	43	57	53	54	48	51	50	58	55	56	51	53	54	61	59	60	55	56	59				
	350	.57	53	54	52	48	51	46	59	55	56	49	52	53	60	57	58	52	54	56	63	61	62	56	58	61				
6	140	.05	37	29	28	28	27	24	44	41	44	42	41	37	47	43	46	44	43	40	50	48	51	48	46	44				
	200	.10	42	37	36	34	34	31	49	46	48	45	45	43	51	48	50	47	47	45	55	53	55	51	50	50				
	300	.23	48	45	44	42	42	40	54	51	52	49	49	49	56	54	55	51	51	52	60	59	59	55	54	56				
	400	.41	52	51	50	47	48	46	57	55	56	51	53	53	62	60	60	55	57	58	63	63	63	57	58	61				
	500	.63	55	56	55	51	53	50	60	59	58	53	55	57	62	61	61	55	57	60	66	66	65	59	60	64				
7	170	.03	39	27	23	23	22	22	50	44	44	44	45	42	52	47	48	47	47	45	56	53	53	52	50	50				
	200	.05	41	30	27	27	26	26	52	47	46	46	46	44	54	50	49	49	48	47	59	55	55	53	52	52				
	400	.20	51	44	42	42	43	42	61	57	54	52	53	53	64	60	57	55	55	56	68	66	63	60	59	60				
	600	.47	57	52	51	51	52	51	67	63	59	56	57	58	70	66	62	59	59	61	74	72	67	64	62	65				
	700	.65	59	56	55	55	56	55	69	66	61	58	58	60	72	69	64	61	60	63	76	74	69	65	64	67				
8	200	.03	34	28	25	30	27	22	50	49	49	47	48	44	53	52	52	51	51	47	57	57	58	56	56	53				
	400	.13	46	43	40	41	40	37	59	58	55	53	53	52	62	61	59	56	56	55	67	66	65	62	61	61				
	600	.31	54	51	48	48	48	46	65	64	59	56	57	56	68	67	63	59	59	60	72	72	68	65	64	66				
	800	.57	59	57	54	53	53	52	69	67	62	58	59	60	71	70	65	61	62	63	76	76	71	67	67	69				
	1000	.91	63	62	59	56	58	57	72	70	64	60	60	62	74	73	67	63	63	66	79	79	73	69	68	72				
10	380	.02	37	30	23	24	22	22	52	53	51	49	50	47	55	57	55	53	53	50	61	64	61	59	57	55				
	500	.04	41	36	30	30	29	28	56	56	54	52	52	50	59	60	57	55	55	53	65	67	64	61	59	58				
	800	.11	49	46	41	41	41	40	62	62	58	56	56	55	65	66	61	60	59	58	71	73	68	66	63	63				
	1200	.24	56	55	51	51	51	49	67	67	61	60	59	59	71	71	65	64	62	62	77	77	71	69	66	67				
	1500	.37	60	60	56	56	57	55	70	69	63	62	61	61	74	73	67	66	63	64	80	80	73	72	68	69				
12	500	.02	34	27	20	20	18	17	56	55	52	50	51	49	59	59	55	54	53	52	66	66	61	59	58	58				
	800	.06	44	38	33	32	31	29	61	60	57	55	54	53	65	64	61	58	57	56	71	71	66	64	61	62				
	1200	.14	52	47	44	43	42	40	66	64	62	59	57	57	70	68	65	62	60	60	76	75	71	68	64	66				
	1800	.33	60	57	56	53	53	51	71	68	66	63	60	60	75	72	69	66	62	64	81	79	75	71	67	69				
	2300	.56	65	63	63	59	59	58	74	70	69	65	62	63	78	74	72	68	64	66	84	81	78	74	68	71				
14	620	.02	36	23	15	16	13	13	57	54	52	48	45	42	60	59	55	52	48	45	67	66	60	58	54	52				
	1000	.04	43	34	29	28	24	23	62	58	57	53	49	45	66	63	60	56	52	49	72	71	65	62	58	55				
	1600	.11	51	44	43	39	35	32	67	63	62	57	53	49	71	67	65	61	56	53	77	75	70	67	62	59				
	2400	.23	57	53	56	49	45	40	71	66	67	61	56	52	75	71	70	65	60	56	82	78	74	71	66	62				
	3100	.38	61	58	63	55	51	45	74	69	69	64	58	54	78	73	72	67	62	58	85	81	77	73	68	64				
16	780	.04	37	30	23	20	17	16	60	56	55	50	46	41	64	60	58	54	49	45	70	67	63	60	55	52				
	1600	.18	52	46	44	41	37	33	68	62	62	58	53	48	72	66	65	62	57	52	78	73	70	68	63	59				
	2400	.42	61	55	56	53	48	43	72	66	66	63	57	52	76	70	69	67	61	56	82	76	74	73	67	63				
	3600	1.00	77	69	70	68	62	56	77	69	70	68	62	56	80	73	73	71	65	60	87	80	78	77	72	67				
	4200	1.38	78	71	73	70	63	57	78	71	72	69	63	57	82	75	74	73	67	61	89	81	80	79	73	68				

- NOTES:**
1. Based on tests conducted in accordance with AHRI Standard 880-2008.
  2.  $\Delta P_s$  static pressure difference from inlet to discharge.
  3.  $\Delta P_s$  is the minimum pressure required to deliver CFM shown with primary damper in wide open position.
  4. Dash (—) indicates db level less than 10.



A Participating Member in the AHRI 880 Certification Program

**Sound Data (Sound Power by Octave Band)**

**Radiated Sound Power**

Inlet Size (Inches)	CFM	Minimum $\Delta P_s$							1.0" $\Delta P_s$							1.5" $\Delta P_s$							3.0" $\Delta P_s$							
		$\Delta P_s$	Sound Power (db) by Octave Band							Sound Power (db) by Octave Band							Sound Power (db) by Octave Band							Sound Power (db) by Octave Band						
			(2)	(3)	(4)	(5)	(6)	(7)	(7)	(2)	(3)	(4)	(5)	(6)	(7)	(7)	(2)	(3)	(4)	(5)	(6)	(7)	(7)	(2)	(3)	(4)	(5)	(6)	(7)	(7)
5	140	.09	46	38	28	25	22	22	52	43	37	33	33	30	53	45	39	36	38	36	54	48	43	42	46	45				
	200	.18	49	42	33	29	26	24	56	47	40	35	34	31	56	49	42	38	39	37	58	52	47	45	47	46				
	250	.29	51	44	36	32	29	26	58	50	42	36	35	32	61	53	46	42	42	40	60	55	49	46	48	47				
	300	.42	53	46	39	34	31	27	60	52	44	38	37	34	61	53	46	42	42	40	62	57	51	48	50	49				
	350	.57	54	48	41	36	33	28	62	53	45	38	36	34	62	55	47	42	42	40	64	58	51	48	50	49				
6	140	.05	40	29	22	18	17	19	44	40	34	29	29	26	45	42	37	32	32	31	48	46	42	38	39	39				
	200	.10	44	34	27	23	21	22	49	44	38	32	32	29	50	46	41	36	35	34	53	50	45	41	42	42				
	300	.23	48	41	34	29	27	25	54	48	42	36	35	32	56	50	45	39	39	37	58	54	49	45	45	45				
	400	.40	52	45	38	33	30	28	58	51	45	38	37	34	62	56	49	44	43	41	63	57	52	47	47	47				
	500	.63	54	49	42	36	33	30	62	54	47	40	39	36	63	56	50	44	43	41	66	60	55	49	49	48				
7	170	.03	37	30	24	20	21	21	46	41	35	32	32	31	48	44	39	35	36	35	50	48	44	41	42	43				
	200	.05	39	32	26	22	22	23	48	42	37	33	33	31	50	45	40	36	36	36	52	50	46	42	43	43				
	400	.20	49	42	36	31	28	28	57	50	43	38	36	34	58	53	46	41	40	39	61	57	52	46	46	47				
	600	.47	54	48	41	35	32	32	62	54	46	41	38	36	63	57	50	44	42	41	66	62	55	49	48	48				
	700	.65	57	50	43	37	33	33	63	56	48	42	39	37	65	58	51	45	42	41	68	63	57	50	49	49				
8	200	.03	42	30	19	15	13	15	48	42	38	35	37	36	49	45	42	39	41	41	52	50	47	45	48	49				
	400	.13	50	41	32	27	26	26	57	50	45	41	41	40	58	53	48	44	45	45	61	58	53	50	52	53				
	600	.31	54	47	40	34	34	32	62	55	48	44	43	42	64	57	51	47	47	47	67	62	57	53	54	55				
	800	.57	57	51	45	39	39	37	66	58	51	46	45	44	67	61	54	49	49	49	70	65	59	55	55	57				
	1000	.91	59	55	49	43	43	40	68	60	53	48	46	45	70	63	56	51	50	50	73	68	61	57	57	58				
10	380	.02	43	32	17	16	16	18	49	43	41	35	32	29	51	46	45	39	36	34	55	51	51	46	44	42				
	500	.04	46	35	23	20	19	21	53	46	43	37	33	31	55	49	47	41	38	35	59	54	54	48	45	43				
	800	.11	51	41	32	28	25	25	60	52	47	40	35	33	62	54	51	44	40	38	65	59	57	51	47	46				
	1200	.24	56	46	40	34	30	29	65	56	50	42	37	35	67	59	54	47	42	40	71	64	61	54	49	48				
	1500	.37	59	49	45	37	33	31	68	59	52	44	38	37	70	61	56	48	43	41	74	66	62	55	50	49				
12	500	.02	35	25	16	16	12	17	53	46	43	37	35	32	56	50	46	41	39	37	61	56	53	47	46	45				
	800	.06	44	33	27	24	21	23	60	50	47	41	38	36	62	54	50	45	42	41	67	61	56	51	49	49				
	1200	.14	52	41	37	32	29	27	65	54	50	44	41	39	68	58	54	48	45	44	72	65	60	54	52	52				
	1800	.33	59	48	47	39	36	32	70	58	54	48	44	43	73	62	57	51	48	47	78	69	63	57	54	56				
	2300	.56	64	53	53	44	40	35	73	61	56	50	45	45	76	65	59	53	49	49	81	71	65	59	56	58				
14	620	.02	41	27	17	18	17	17	53	47	43	36	31	29	56	51	46	40	35	34	62	58	52	46	43	42				
	1000	.04	46	34	28	24	23	21	57	50	46	38	34	31	61	55	50	42	38	36	67	62	56	49	45	44				
	1600	.11	51	42	38	31	28	25	62	54	50	41	36	33	65	58	53	45	40	37	71	65	59	52	48	46				
	2400	.23	55	48	47	36	32	28	66	57	53	44	38	34	69	61	56	48	43	39	75	68	62	54	50	48				
	3100	.38	58	52	52	40	35	30	68	59	55	45	40	35	72	63	58	49	44	40	78	70	64	56	51	49				
16	780	.04	41	30	20	14	13	16	56	50	47	39	31	29	60	54	50	43	36	34	66	61	55	49	43	41				
	1600	.18	52	44	39	33	28	26	61	55	53	45	37	33	65	59	55	49	42	37	72	66	60	56	49	45				
	2400	.42	59	53	49	44	36	31	65	58	56	49	41	35	69	62	59	53	45	39	75	69	64	59	52	47				
	3600	1.00	68	61	60	54	45	37	68	61	60	54	45	37	72	64	62	57	48	42	79	71	67	63	56	49				
	4200	1.38	68	64	64	58	48	39	69	61	60	54	45	38	73	66	63	58	49	42	80	72	68	64	57	50				

- NOTES:**
1. Based on tests conducted in accordance with AHRI Standard 880-2008.
  2.  $\Delta P_s$  static pressure difference from inlet to discharge.
  3.  $\Delta P_s$  is the minimum pressure required to deliver CFM shown with primary damper in wide open position.
  4. Dash (—) indicates db level less than 10.



A Participating Member in the AHRI 880 Certification Program

# MODEL NUMBERING SYSTEM | Model ADCD

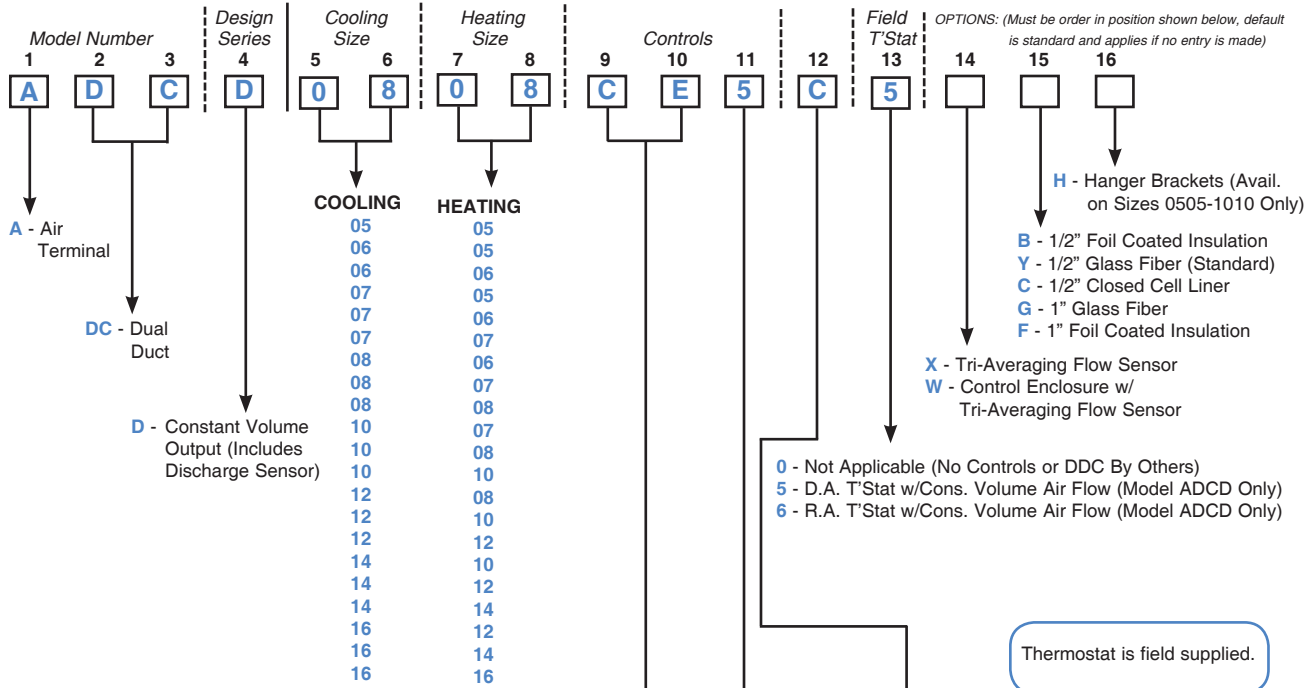

**CONTROL TYPE and OPTION**

- CE - Pneumatic Actuator by Carnes, Reset Controller by Carnes
- CX - Pneumatic Actuator by Carnes, (Multi-function) Reset Controller by Carnes
- DD - SimplyVAV, DDC by Carnes
- DO - DDC Provided by Others, Mounted and Wired by Carnes, w/Carnes Inlet Sensor, w/3/8" Damper Shaft, w/Enclosure
- DE - No Damper Controls. Enclosures w/Carnes Inlet Sensor, w/Bare 3/8" Damper Shaft
- NS - No Damper Controls, w/Carnes Inlet Sensor, w/Bare 3/8" Damper Shaft (No Enclosure)

**NOTE:** Hand of controls is determined by facing the averaging flow sensor (inlet of the unit) with the supply air hitting the back of your head.

**ACTUATOR VENDOR**

- C - CARNES
- D - DDC ACTUATOR (DO Option Only)
- N - NOT APPLICABLE (No Controls) (NS, DE Option Only)

**DAMPER CONFIGURATIONS**

COOLING	HEATING
* 1 - Right Hand w/Normally Open Damper	Left Hand w/Normally Closed Damper
* 2 - Left Hand w/Normally Open Damper	Right Hand w/Normally Closed Damper
3 - Right Hand w/Normally Closed Damper	Left Hand w/Normally Open Damper
4 - Left Hand w/Normally Closed Damper	Right Hand w/Normally Open Damper
5 - Right Hand w/Normally Open Damper	Left Hand w/Normally Open Damper
6 - Left Hand w/Normally Open Damper	Right Hand w/Normally Open Damper
7 - Right Hand w/Normally Closed Damper	Left Hand w/Normally Closed Damper
8 - Left Hand w/Normally Closed Damper	Right Hand w/Normally Closed Damper

\* DDC Units DO NOT FAIL OPEN. "1" or "2" Is Used For Right or Left Hand Only.

## Direct Digital Control (DD/DC/DM)

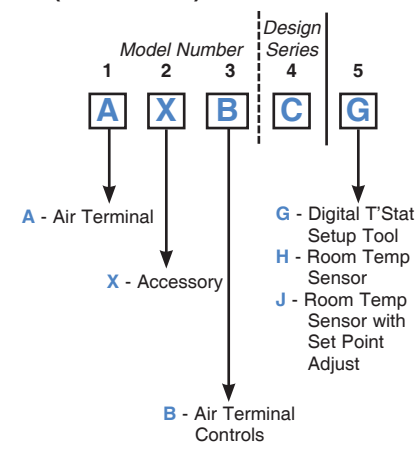

## AVAILABLE CONTROL TYPES/DAMPER CONFIGURATION/T'STAT COMBINATIONS

Control Types 9 10 [ ] [ ]	Damper Configurations 11 [ ]	T'Stat Types 13 [ ]						
		0	1	2	3	4	5	6
CE or CX	1, 2, 3, 4, 5, 6, 7 or 8	No	Yes	Yes	Yes	Yes	Yes	Yes
DO, DE, NS	1 or 2	Yes	No	No	No	No	No	No

**NOTE:** 5" (127) and 6" (152) inlet will be 1-1/4" (32) off center in the vertical plane.

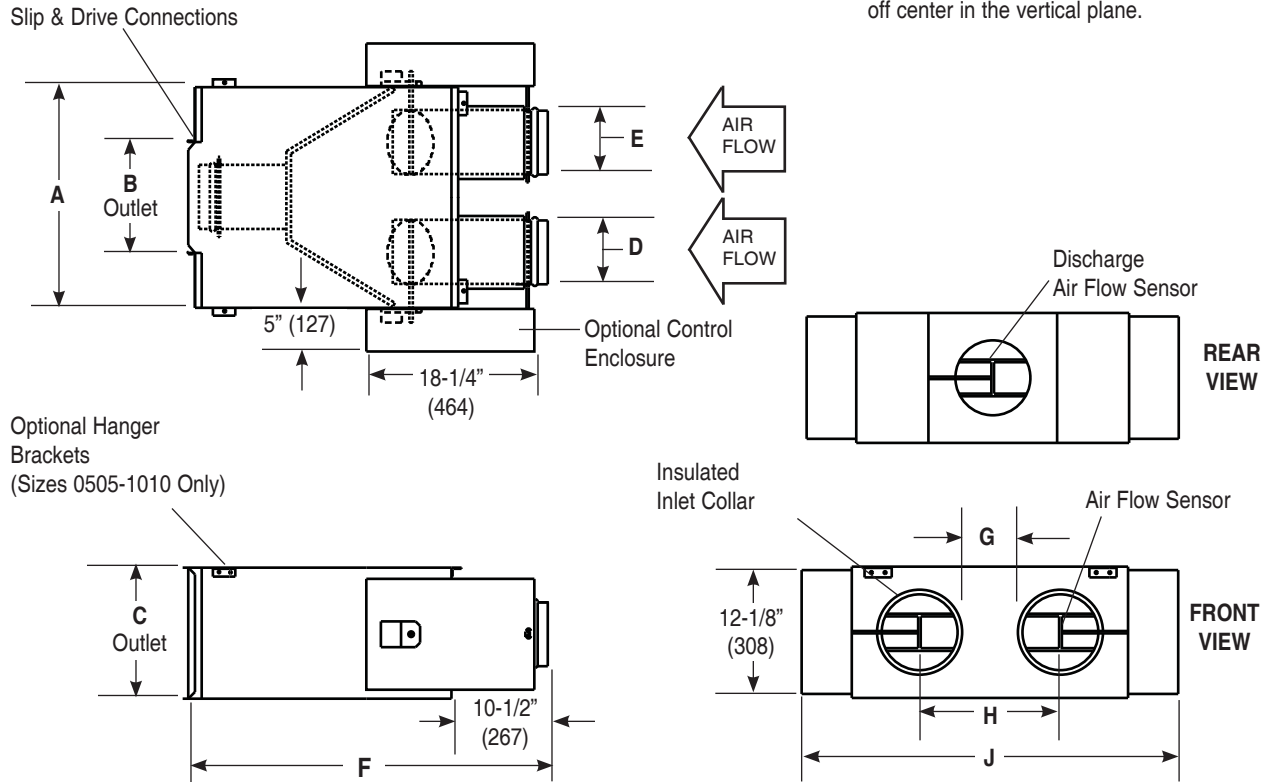

Unit Size	Nominal Max. CFM (L/s)		DIMENSIONS LISTED IN INCHES (Millimeters)								
	Cooling	Heating	Outlet			Inlets			G	H	J
			A	B	C	D	E	F			
0505	350 (165)	350 (165)	24 (610)	12 (305)	10 (254)	4-7/8 (124)	4-7/8 (124)	38-1/2 (978)	9 (229)	14 (356)	34 (864)
0605	500 (236)	350 (165)	24 (610)	12 (305)	10 (254)	5-7/8 (149)	4-7/8 (124)	38-1/2 (978)	8 (203)	13-1/4 (343)	34 (864)
0606		500 (236)					5-7/8 (149)		7 (178)	13 (330)	
0705	700 (330)	350 (165)	24 (610)	12 (305)	10 (254)	6-7/8 (175)	4-7/8 (124)	38-1/2 (978)	7 (178)	13 (330)	34 (864)
0706		500 (236)					5-7/8 (149)		6 (152)	12-1/2 (318)	
0707		700 (330)					6-7/8 (175)		5 (127)	12 (305)	
0806	1000 (472)	500 (236)	24 (610)	12 (305)	10 (254)	7-7/8 (200)	5-7/8 (149)	38-1/2 (978)	5 (127)	12 (305)	34 (864)
0807		700 (330)					6-7/8 (175)		4 (102)	11-1/2 (292)	
0808		1000 (472)					7-7/8 (200)		3 (76)	11 (279)	
1007	1500 (708)	700 (300)	28 (711)	14 (356)	12-1/2 (318)	9-7/8 (251)	6-7/8 (175)	42-1/2 (1080)	6 (152)	14-1/2 (368)	38 (965)
1008		1000 (472)					7-7/8 (200)		5 (127)	14 (356)	
1010		1500 (708)					9-7/8 (251)		3 (76)	13 (330)	
1208	2300 (1085)	1000 (472)	32 (813)	16 (406)	15 (381)	11-7/8 (302)	7-7/8 (200)	44-1/2 (1130)	7 (178)	17 (432)	42 (1067)
1210		1500 (708)					9-7/8 (251)		5 (127)	14 (356)	
1212		2300 (1085)					11-7/8 (302)		3 (76)	15 (381)	
1410	3100 (1463)	1500 (708)	36 (914)	20 (508)	17-1/2 (445)	13-7/8 (353)	9-7/8 (251)	45-1/2 (1156)	7 (178)	19 (483)	46 (1168)
1412		2300 (1085)					11-7/8 (302)		5 (127)	18 (457)	
1414		3100 (1463)					13-7/8 (353)		3 (76)	17 (432)	
1612	4200 (1982)	2300 (1085)	40 (1016)	24 (610)	17-1/2 (445)	15-7/8 (403)	11-7/8 (302)	48-1/2 (1232)	7 (178)	21 (533)	50 (1270)
1614		3100 (1463)					13-7/8 (353)		5 (127)	20 (508)	
1616		4200 (1982)					15-7/8 (403)		3 (76)	19 (483)	