

Left Hand Units:
CCW to by-pass
Right Hand Units:
CW to by-pass

* Electric Units **DO NOT** fail open. "2" is used for Left Hand Only. Electric Units are shipped with the Damper in the Open Position.

NOTE: Hand of controls is determined by facing the averaging flow sensor (inlet of the unit) with the supply air hitting the back of your head.

▼ Electric Thermostat

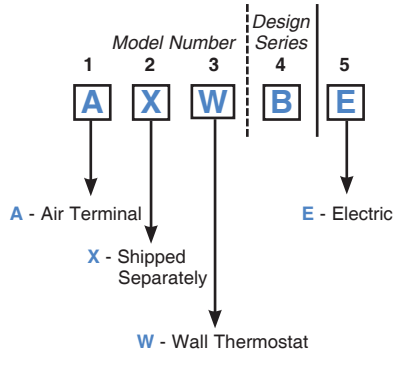

A Carnes Electric Thermostat **must be ordered** with the Electric EA and EB Control Options.

▼ Electronic Thermostat

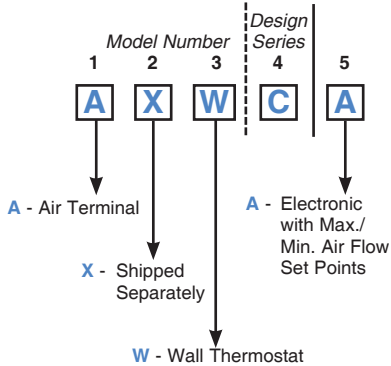

A Carnes Electronic Thermostat **must be ordered** with the ET Electronic Control Option.

▼ Direct Digital Control (DD/DC/DM)

