

CARNES COMPANY 448 S. Main St., P. O. Box 930040, Verona, WI 53593-0040 Phone: (608)845-6411 Fax: (608)845-6504 www.carnes.com

SINGLE PITCH — JCPA

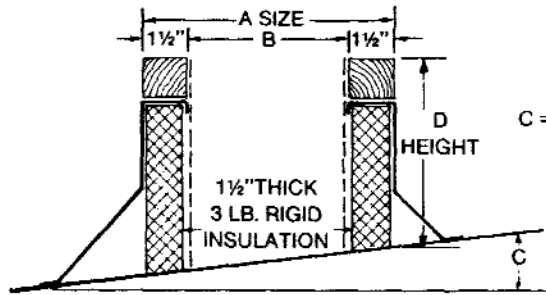

DOUBLE PITCH — JCDA

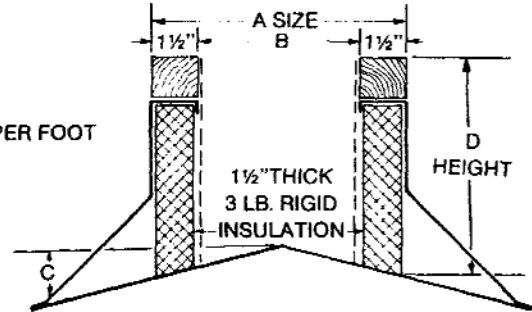

FIGURE 1. Prefabricated (Single Pitched) construction thru 9" rise per foot.

NOTE: When used with Model JCEA extended curb, 1/2" maximum flashing per side.

FIGURE 2. Prefabricated (Double Pitched) up thru 3" rise per foot.

STANDARD FEATURES

1. Factory installed wood nailer.
2. Welded 18 ga. galvanized steel shell and base plate.
3. 1-1/2" thick, 3 lb. rigid insulation.
4. Fully mitered 3" cant.

Used with CARNES VENTILATOR MODEL AND SIZE								
LEDA	LSBA LEBA	VE VU VL VT	GS	CURB SIZE	A	B	PITCH C	D
		06-10		0140	14	11		
		12		0160	16	13		
		15	12	0190	19	16		
		18		0230	23	20		
10-12			16	0234	23-1/2	20-1/2		
				0244	24-1/2	21-1/2		
		21		0264	26-1/2	23-1/2		
	18		22	0270	27	24		
16/18		24		0294	29-1/2	26-1/2		
	24		28	0354	35-1/2	32-1/2		
		30		0384	38-1/2	35-1/2		
24	30		32	0414	41-1/2	38-1/2		
		36		0444	44-1/2	41-1/2		
	36		38	0474	47-1/2	44-1/2		
		44		0524	52-1/2	49-1/2		
	42		46-52	0554	55-1/2	52-1/2		
		54		0624	62-1/2	59-1/2		
	48		60	0654	65-1/2	62-1/2		

LOCATION	QTY.	CURB MODEL	CURB SIZE	SINGLE PITCH				DOUBLE PITCH			
				A	B	C	D	A	B	C	D

NOTE: Size curb "A" 1-1/2" less than curb cap to allow for flashing.