

**Metric (SI) Dimensions**  
**Imperial [IP] on Reverse Side**

CARNES COMPANY 448 S. Main St., P. O. Box 930040, Verona, WI 53593-0040 Phone: (608)845-6411 Fax: (608)845-6504 www.carnes.com

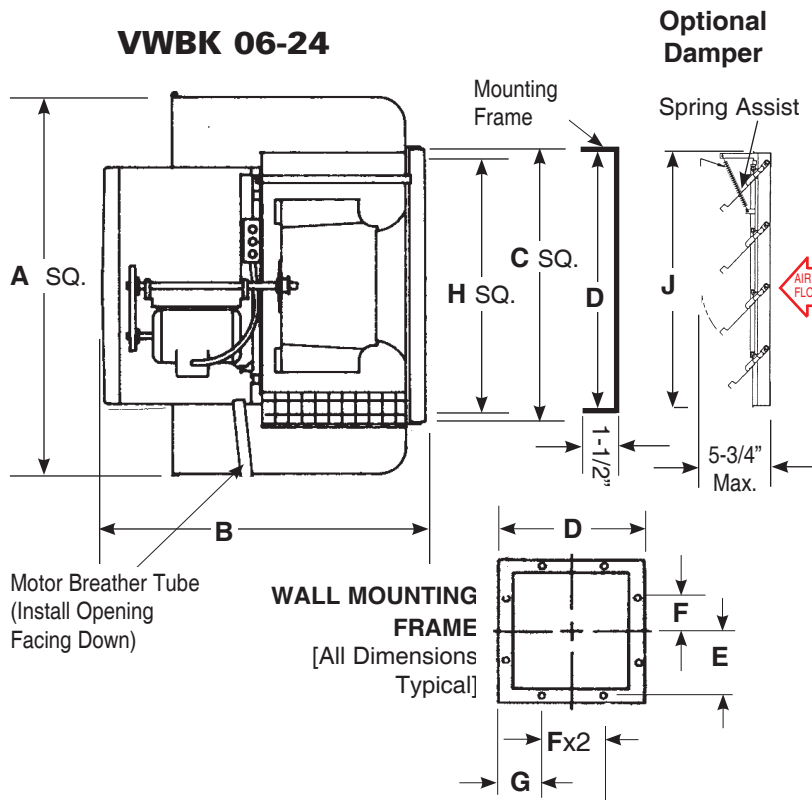

#### STANDARD FEATURES

- Spun and shaped aluminum housing, mill finish standard.
- Integral motor overload protection on all single phase motors.
- Disconnect switch on all motors except explosion proof.
- Ventilated motor compartment with motor out of airstream.
- Non-overloading, backwardly inclined wheel.
- Isolated motor wheel-drive assembly.
- Spark resistant construction.
- Heavy gauge welded galvanized 1/2" x 1/2" birdscreen.
- Adjustable motor sheave factory preset to requested RPM.
- Wall mounting frame for simplified installation.
- Pillow block bearing L<sub>50</sub> = 200,000 hours.

STANDARD DIMENSIONS [In Inches]										
Unit Size	Unit Dia. A	Unit Depth B		Mounting Cap C	Mounting Frame 1-1/2 x 1-1/2 x 1-1/2 Angle				Wall Opening Sq. H	Damper Size J
		Standard B	Extended B		OD D	E	F	G		
06	25-5/8	23-1/4	28	15-1/2	15-3/8	6-15/16	4-11/16	3	12	12
08	25-3/4	24-5/8	29-3/8	15-1/2	15-3/8	6-15/16	4-11/16	3	12	12
10	27-5/8	25-1/4	30	17-5/8	17-1/2	8	5-3/4	3	14	14
12	27-3/4	26-7/8	31-5/8	17-5/8	17-1/2	8	5-3/4	3	14	14
15	32-3/4	29-7/8	34-5/8	20-1/2	20-3/8	9-7/16	7-3/16	3	17	17
18	38-3/4	31-1/8	35-7/8	25	24-7/8	11-11/16	7-7/16	5	22	22
21	44-3/4	35-1/2	39-1/8	28-1/8	28	13-1/4	9	5	25	25
24	48-3/4	38-1/2	42-1/2	31-1/8	31	14-3/4	10-1/2	5	28	28

STANDARD MATERIAL AND THICKNESS IN INCHES (Millimeters)							
Unit Size	Motor Cover		Outer Shroud [Alum.]	Curb Cap [Alum.]	Std. Wheel	Diffuser [Galvanized Steel]	Approx. Wt. Less Motor Lbs.
	Lid [Alum.]	Tube [Alum.]					
06	.063	.040	.080	.050	Aluminum	22 ga.	45
08	.063	.040	.080	.050	Aluminum	22 ga.	45
10	.063	.040	.080	.063	Aluminum	22 ga.	50
12	.063	.040	.080	.063	Aluminum	22 ga.	50
15	.063	.040	.080	.063	Aluminum	20 ga.	75
18	.063	.040	.080	.063	Aluminum	18 ga.	85
21	.063	.040	.080	.080	Aluminum	18 ga.	130
24	.063	.040	.080	.080	Aluminum	18 ga.	160

**Metric (SI) Dimensions**  
**Imperial [IP] on Reverse Side**

CARNES COMPANY 448 S. Main St., P. O. Box 930040, Verona, WI 53593-0040 Phone: (608)845-6411 Fax: (608)845-6504 www.carnes.com

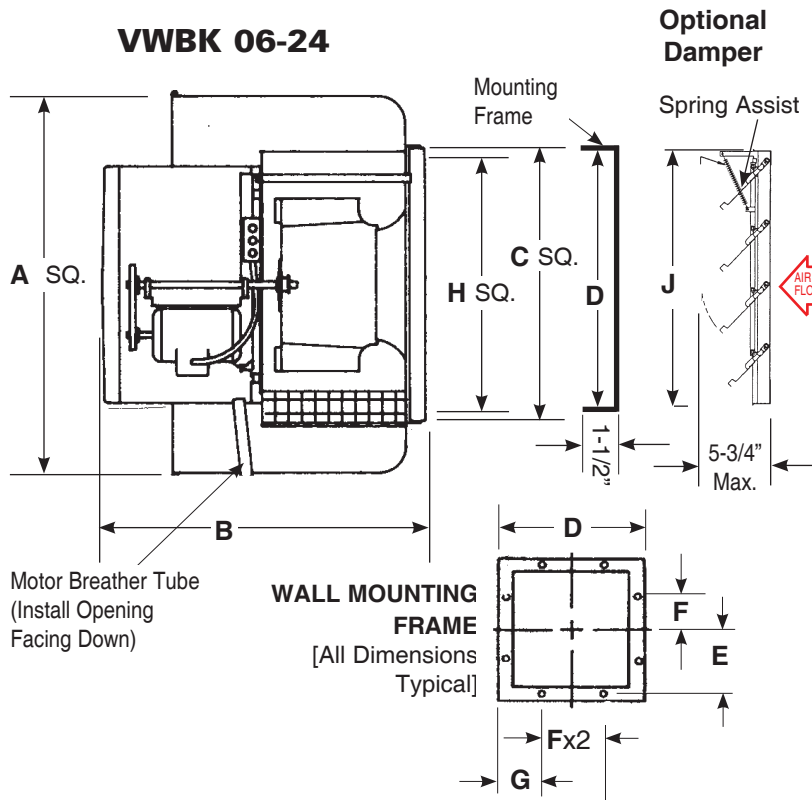

#### STANDARD FEATURES

- Spun and shaped aluminum housing, mill finish standard.
- Integral motor overload protection on all single phase motors.
- Disconnect switch on all motors except explosion proof.
- Ventilated motor compartment with motor out of airstream.
- Non-overloading, backwardly inclined wheel.
- Isolated motor wheel-drive assembly.
- Spark resistant construction.
- Heavy gauge welded galvanized 1/2" x 1/2" birdscreen.
- Adjustable motor sheave factory preset to requested RPM.
- Wall mounting frame for simplified installation.
- Pillow block bearing L<sub>50</sub> = 200,000 hours.

#### STANDARD DIMENSIONS (In Millimeters)

Unit Size	Unit Dia. A	Unit Depth B		Mounting Cap C	Mounting Frame 38.1 x 38.1 x 38.1 Angle				Wall Opening Sq. H	Damper Size J
		Standard B	Extended B		OD H	D	E	G		
06	651	591	711	394	397	176	119	76	305	305
08	654	625	746	394	391	176	119	76	305	305
10	702	641	762	448	445	203	146	76	356	406
12	705	683	803	448	445	203	146	76	356	406
15	832	759	879	521	772	240	183	76	432	432
18	984	791	911	635	632	297	189	127	559	559
21	1137	902	994	714	711	337	229	127	635	635
24	1238	978	1080	791	787	375	267	127	711	711

#### STANDARD MATERIAL AND THICKNESS IN INCHES (Millimeters)

Unit Size	Motor Cover		Outer Shroud [Alum.]	Curb Cap [Alum.]	Std. Wheel	Diffuser [Galvanized Steel]	Approx. Wt. Less Motor Kgs.
	Lid [Alum.]	Tube [Alum.]					
06	1.6	1.0	2.0	1.3	Aluminum	0.8	20
08	1.6	1.0	2.0	1.3	Aluminum	0.8	20
10	1.6	1.0	2.0	1.6	Aluminum	0.8	23
12	1.6	1.0	2.0	1.6	Aluminum	0.8	23
15	1.6	1.0	2.0	1.6	Aluminum	0.9	34
18	1.6	1.0	2.0	2.0	Aluminum	1.2	39
21	1.6	1.0	2.0	2.0	Aluminum	1.2	59
24	1.6	1.0	2.0	2.0	Aluminum	1.2	73