

**Imperial [IP] / Metric (SI)
Dimensions**

CARNES COMPANY 448 S. Main St., P. O. Box 930040, Verona, WI 53593-0040 Phone: (608)845-6411 Fax: (608)845-6504 www.carnes.com

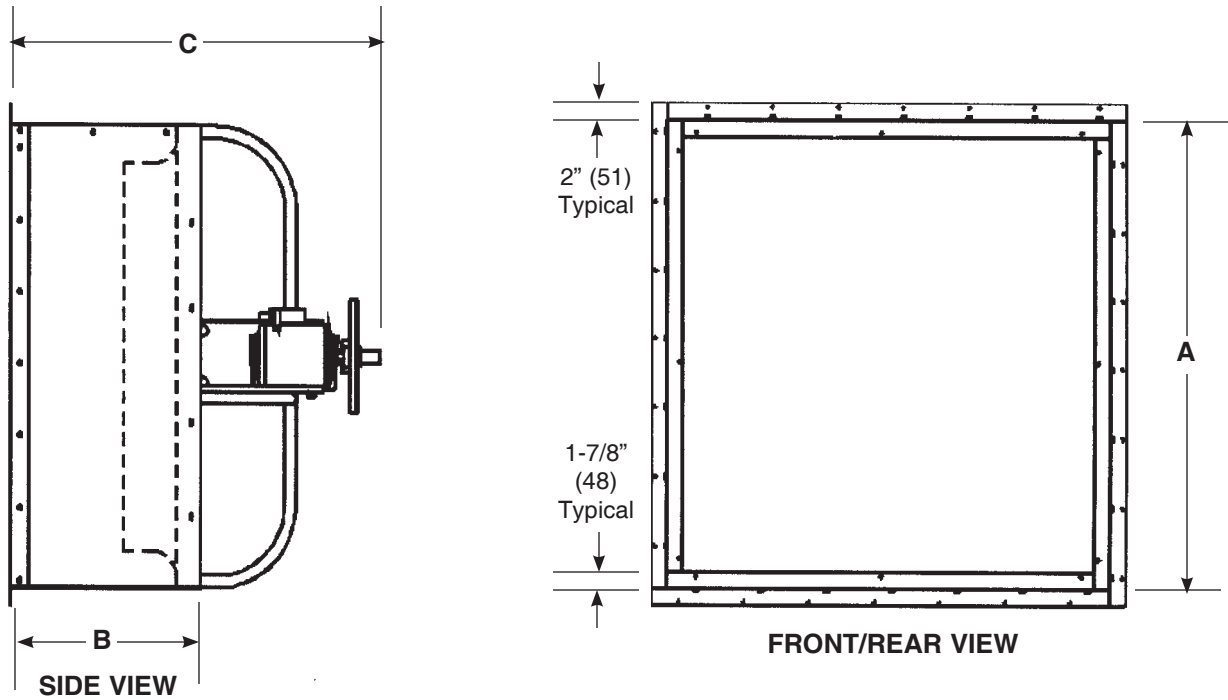

LOUVER EXTENSION:

FINISHES:

Mill as standard.

OPTIONAL FINISHES:

Air Dry Enamel to match.

Acid Resistant coating (ARC, Epoxy).

Air Dry Heresite.

DIMENSIONS LISTED IN INCHES

Fan Size	A Sq. O. D.	B Length	C Panel Locate	Weight (lbs.)	Wall Opening
20	26-1/4	17-1/2	35-3/8	32	27-1/2
24	30-1/4	17-1/2	35-3/8	37	31-1/2
30	36-1/4	17-1/2	38-3/8	44	38
36	42-1/4	18-1/2	41-3/8	53	44
42	48-1/4	20-3/4	43-5/8	67	50
48	54-1/4	22-3/4	45-5/8	82	56

DIMENSIONS LISTED IN MILLIMETERS

Fan Size	A Sq. O. D.	B Length	C Panel Locate	Weight (Kg.)	Wall Opening
20	688	444	898	15	699
24	768	444	898	17	800
30	921	444	974	20	965
36	1073	470	1051	24	1117
42	1226	527	1108	31	1270
48	1378	578	1159	37	1422