

## CENTRIFUGAL UPBLAST ROOF EXHAUSTERS HIGH TEMPERATURE SMOKE EXHAUST APPLICATIONS Belt Driven Model VQBL

### DESIGNED AND ENGINEERED TO MEET INDUSTRY NEEDS

The Carnes Company VQ series centrifugal upblast fan is designed and built to handle the exhaust of extremely hot, smoke laden air during emergency fire situations. The fan discharges unbreathable air to provide vital minutes for emergency evacuations. These fans are to be roof mounted only.

The redesigned backward inclined wheel and new support structure are made from heavy gauge steel to withstand the extreme temperatures while still providing consistent operation at high static pressures of up to 3.0 inches w.g.

The deep spun venturi is precision matched to the wheel inlet to ensure maximum air flow along with protection from entry of adverse weather elements. The air flow design of these fans has been thoroughly tested at Carnes' accredited laboratory.

Rigorous testing, with temperatures exceeding 1000 degrees, was performed to ensure proper operation when it matters most.

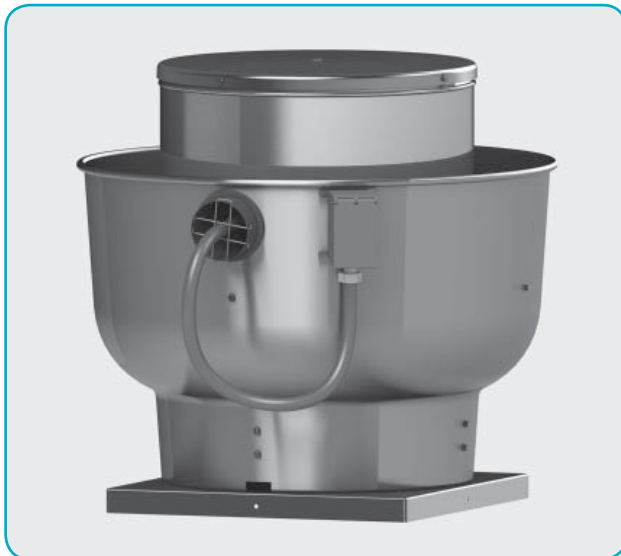

### Model VQBL - Sizes 06 through 18

Designed for roof mounted installations only.

Model VQBL sizes 06-18 incorporate a new support structure. This improved design provides superior structural integrity and decreases exhaust air obstruction. The new one piece aluminum shroud construction provides a seamless transition from outer shroud to Venturi inlet and incorporates a smaller neck diameter which increases fan efficiency and performance and reduces overall size.

**▼ TYPICAL SPECIFICATIONS  
VQBL Belt Drive Series**

Upblast exhaust ventilators shall be of the centrifugal belt driven type. The motor compartments shall be constructed of heavy gauge aluminum mounted on an independent steel support structure. The outer shroud shall have a rolled bead for added strength. The wheel shall be a centrifugal design made from heavy gauge steel. The wheel shall overlap the inlet venturi and have backward inclined blades. For maximum performance and quiet, efficient operation. The wheels shall be dynamically balanced to assure smooth and vibration-free rotation under maximum loading. The complete drive assembly, including the motor and wheel, shall be mounted on vibration isolators. Motor and drives shall be factory mounted. All fans shall be test run prior to shipment.

Motor and drives shall be isolated from the exhaust air-stream. Air for cooling the motor shall be supplied to the internal motor compartment through a vent tube from a location free from discharge contaminants. Motors shall be of the heavy duty type with permanently lubricated, sealed ball bearings. Motors shall be readily accessible for maintenance. Wheel shaft shall be ground, polished, coated with a rust inhibitive finish and mounted in heavy duty,

permanently sealed pillowblock ball bearings which are capable of 200,000 hours of life, average operation. Drives shall be sized at a minimum of 165% of driven horsepower. Drive belts shall be oil-resistant, non-static and be capable of 25,000 hours of life, average operation. Sheaves shall be fully machined cast iron or pressed steel, keyed and securely attached to the shafts. Dual groove, variable pitch motor sheaves shall be standard.

The motor shall be factory wired to the disconnect switch which shall be mounted in a weatherproof enclosure and attached to the exterior of the shroud. Wiring connected to the motor will travel through liquid tight, flexible metal conduit to a weatherproof disconnect enclosure on the exterior of the unit.

Horsepower levels shall not exceed the published values and oversized motors will not be acceptable. Performance ratings shall be AMCA licensed for air performance.

Centrifugal power upblast ventilators for high temperature smoke exhaust applications shall be Carnes Company Model VQBL, belt drive, sizes 06 through 18, as manufactured at Carnes Company of Verona, Wisconsin.

**AMCA LICENSED AIR DATA**

Licensed to bear the AMCA Seal for air.

The Carnes Company certifies that the Model VQ shown herein is licensed to bear the AMCA Seal. The ratings shown are based on tests and procedures performed in accordance with AMCA Publication 211 and comply with the requirements of the AMCA Certified Ratings Program.



**UL LISTING**

Listed by Underwriters Laboratories for use in the United States and Canada under the following standards:

- UL 705
- CSA C22.2 No. 113



**POWER VENTILATOR  
FOR SMOKE CONTROL  
SYSTEMS**

Ventilators in this section have been tested to withstand the following conditions prescribed by industry accepted recommendations:

- 500°F for no less than 4 hours
- 1000°F for 25 minutes

## CONSTRUCTION

### FAN HOUSING

- Constructed with heavy gauge aluminum.
- Designed for maximum weather protection, outer shroud prevents the entrance of inclement weather.
- Outer shroud beaded for rigidity.
- Fan plate designed to prevent the entrance of contaminated air and airborne particles into the motor compartment.
- Two piece motor cover design (lid and motor tube) allows easy access to motor, drives and bearings for maintenance.
- Drain opening.

### MOTOR/ELECTRICAL

- Motors are **UL** recognized components supplied by nationally recognized manufacturers.
- Disconnect is mounted and wired.
- Wiring external to exhaust air.

### MOTOR SUPPORT ASSEMBLY

- Bolted, heavy gauge galvanized steel.
- Easily adjustable belt tension.
- Motor plate accommodates multiple motor frames.
- Isolated from fan plate to reduce vibration and noise transmission.
- Allows horizontal adjustment of wheel.
- Electrically grounded to meet **NEC** and **UL** requirements.

### MOTOR COMPARTMENT/TUBE

- Motor compartment insulated for operating temperatures to 1000°F.
- Vent tube provides positive motor cooling to maximize motor life.
- Easily removable lid and tube utilize durable threaded fastener retainers.
- Fan plate isolates motor compartment from contaminated exhaust air.
- Opening around shaft sized to allow optimum air passage to ensure proper motor compartment cooling.

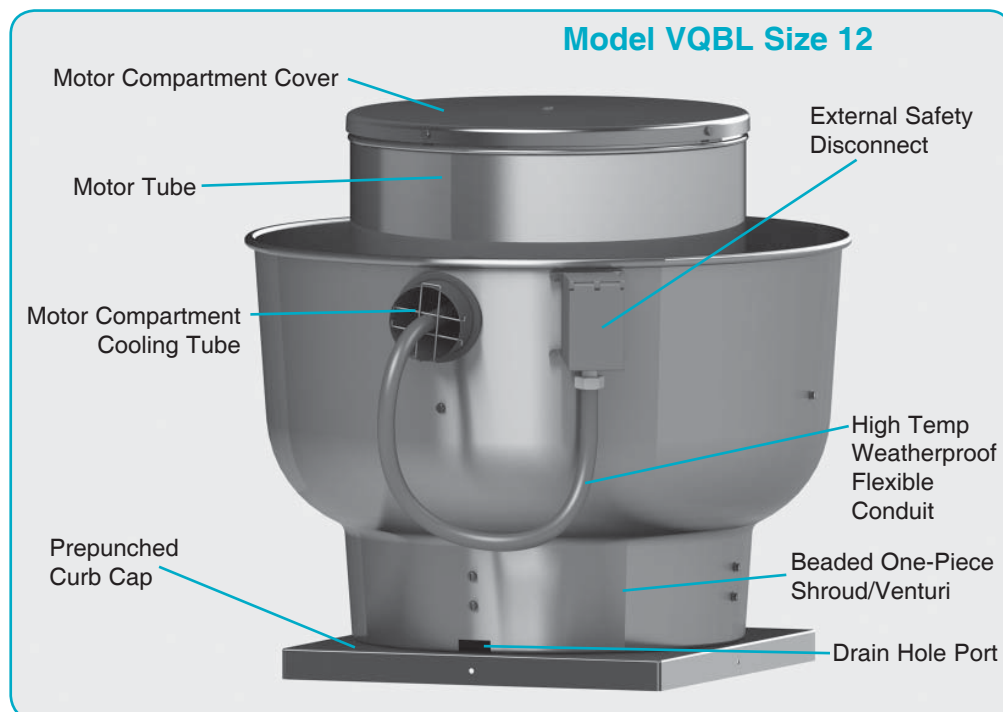

## FEATURES

### BEARINGS/SHAFT

- Dual bearings utilized to properly support the fan shaft.
- Prelubricated sealed, self-aligning.
- Rated at 200,000 hours average operation.
- Polished CRS fan shaft with rust inhibitive coating.

### DRIVES

- Selected for 165% of the motor horsepower.
- Adjustable V-belt drives with oil resistant non-static conducting belts.
- Two belts standard on all units.
- Factory preset fan RPM.
- Adjustable sheaves allow for final air system balancing.

### WHEEL

- Backward inclined wheels constructed of coated heavy gauge steel.
- Usage of cooling fins on fan wheel backplate draws cooling air down over the motor facilitating motor longevity while motor remains out of the airstream.
- Self-limiting power characteristics.
- Dynamically balanced and test run in each individual unit.

### SUPPORT STRUCTURE

#### Sizes 06 - 18

- New support structure drastically reduces exhaust air obstruction, increasing efficiency.
- Made from heavy gauge steel to resist high temperatures.

### CURB CAP

- One piece construction with fastened/welded, overlapping corners to ensure strength.
- Prepunched mounting holes for ease of installation.
- The deep spun venturi is precision matched to the wheel inlet to ensure maximum air flow along with protection from entry of adverse weather elements.

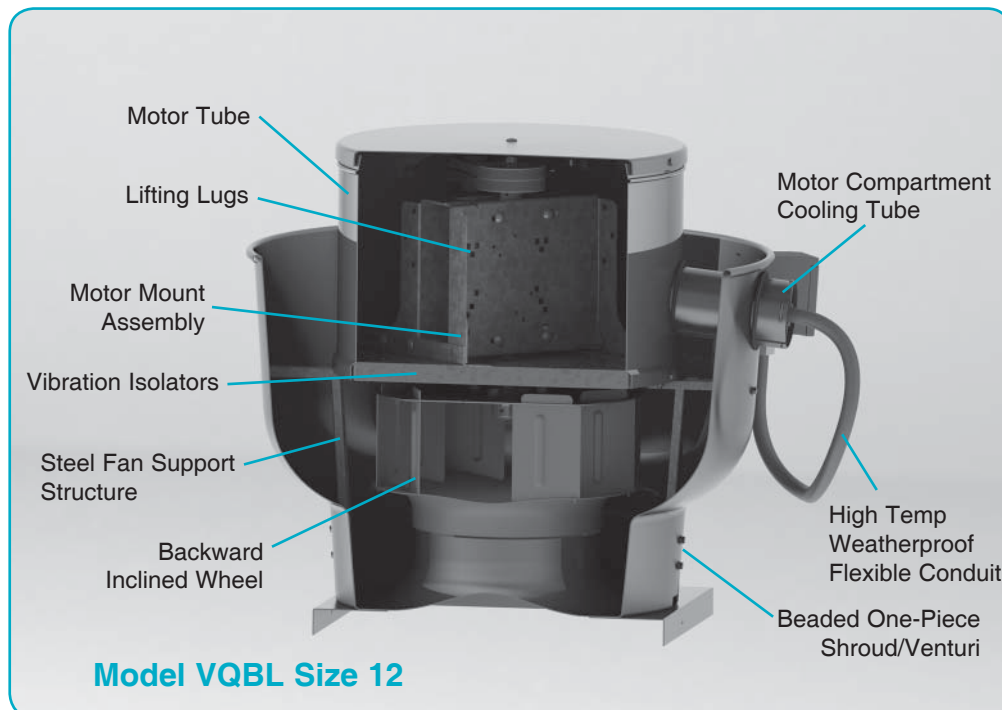

# VQBL 06

## BELT DRIVE

### PERFORMANCE DATA

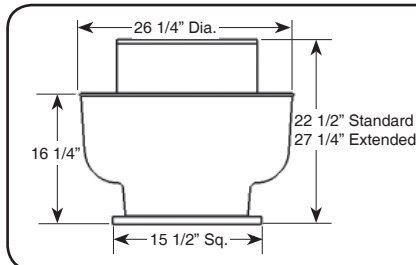

#### DESIGN DATA

Max BHP =  $.033 \times \left[ \frac{\text{RPM}}{1000} \right]^3$   
 Tip Speed = 2.75 x RPM  
 Max. Motor Frame Size = 56  
 Unit Weight (less motor) = 40 lbs.  
 Roof Opening = 11" Sq.  
 Curb O. D. = 14" Sq.

RPM Range - Motor HP	RPM	STATIC PRESSURE, INCHES W.G.																									
		0.000		0.125		0.250		0.375		0.500		0.625		0.750		1.000		1.250		1.500		1.750		2.000			
		CFM	BHP	CFM	BHP	CFM	BHP	CFM	BHP	CFM	BHP	CFM	BHP	CFM	BHP	CFM	BHP	CFM	BHP	CFM	BHP	CFM	BHP	CFM	BHP		
K1(1/6)	650	247	0.01	171	0.01																						
	750	285	0.01	235	0.01																						
K2(1/6)	850	323	0.02	287	0.02																						
	950	361	0.02	334	0.02	266	0.03																				
K3(1/6)	1050	399	0.03	380	0.03	327	0.04																				
	1150	437	0.04	425	0.04	382	0.05	315	0.05																		
K4(1/6)	1250	475	0.05	470	0.05	429	0.06	379	0.06																		
	1350	513	0.06	505	0.06	475	0.07	436	0.08	381	0.08																
K5(1/6)	1450	551	0.08	534	0.07	521	0.09	487	0.09	442	0.10	381	0.10														
	1500	604	0.07	581	0.08	549	0.08	514	0.09	470	0.09	404	0.09	320	0.09												
L6(1/4)	1550	624	0.08	602	0.09	571	0.09	538	0.10	497	0.10	443	0.10	369	0.10												
	1600	644	0.09	623	0.09	594	0.10	562	0.11	524	0.11	480	0.11	409	0.11												
M7(1/3)	1650	664	0.10	644	0.10	616	0.11	586	0.11	551	0.12	510	0.12	448	0.12												
	1700	685	0.11	666	0.11	639	0.12	609	0.12	577	0.13	538	0.13	487	0.13	313	0.12										
P7(1/2)	1750	705	0.12	687	0.12	661	0.13	632	0.13	603	0.14	565	0.14	524	0.15	394	0.14										
	1800	725	0.13	708	0.13	682	0.14	655	0.15	626	0.15	592	0.16	555	0.16	435	0.16										
P8(1/2)	1850	745	0.14	729	0.14	704	0.15	678	0.16	650	0.16	619	0.17	582	0.17	474	0.17										
	1900	765	0.14	748	0.15	722	0.16	695	0.17	669	0.18	644	0.18	606	0.18	512	0.19	328	0.17								
M7(1/3)	1950	785	0.16	769	0.16	744	0.17	718	0.18	693	0.19	667	0.19	634	0.20	591	0.20	395	0.19								
	2000	805	0.17	790	0.17	766	0.18	740	0.19	715	0.20	691	0.21	662	0.21	584	0.22	460	0.21								
P7(1/2)	2050	825	0.18	811	0.19	788	0.19	762	0.21	738	0.21	714	0.22	689	0.22	615	0.23	513	0.23	294	0.20						
	2100	845	0.19	832	0.20	810	0.21	784	0.22	761	0.23	737	0.24	714	0.24	645	0.25	553	0.25	384	0.23						
P8(1/2)	2150	865	0.21	852	0.21	831	0.22	806	0.23	783	0.24	760	0.25	737	0.26	675	0.27	592	0.27	451	0.26						
	2200	885	0.22	873	0.23	853	0.24	829	0.25	806	0.26	783	0.27	761	0.28	703	0.28	630	0.29	516	0.28						
P7(1/2)	2250	905	0.24	894	0.24	874	0.25	851	0.26	828	0.28	806	0.28	784	0.29	731	0.30	662	0.31	566	0.31	390	0.28				
	2300	926	0.26	915	0.26	896	0.27	873	0.28	850	0.29	829	0.30	807	0.31	759	0.32	692	0.33	606	0.33	457	0.31				
P8(1/2)	2350	946	0.27	935	0.28	917	0.28	895	0.30	873	0.31	852	0.32	831	0.33	786	0.34	723	0.35	645	0.35	523	0.34				
	2400	966	0.29	956	0.29	938	0.30	917	0.31	895	0.33	874	0.34	854	0.35	813	0.36	752	0.37	684	0.38	587	0.37	410	0.34		
P7(1/2)	2450	986	0.31	977	0.31	959	0.32	939	0.33	917	0.35	897	0.36	876	0.37	836	0.38	781	0.39	716	0.40	627	0.40	477	0.37		
	2500	1006	0.33	997	0.33	980	0.34	960	0.35	939	0.37	919	0.38	899	0.39	860	0.41	809	0.41	747	0.43	667	0.43	543	0.41		

Performance certified is for installation type A - free inlet, free outlet.  
 Performance ratings (bhp) do not include transmission losses.  
 Performance ratings do not include the effects of accessories.

# VQBL 08

## BELT DRIVE

### PERFORMANCE DATA

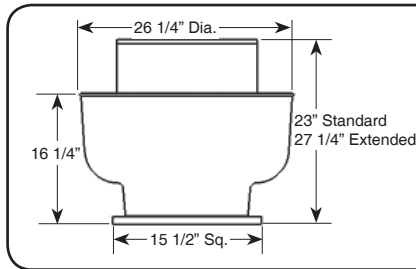

#### DESIGN DATA

Max BHP =  $.033 \times \left[ \frac{\text{RPM}}{1000} \right]^3$

Tip Speed = 2.75 x RPM  
 Max. Motor Frame Size = 56  
 Unit Weight (less motor) = 40 lbs.  
 Roof Opening = 11" Sq.  
 Curb O. D. = 14" Sq.

RPM Range - Motor HP		STATIC PRESSURE, INCHES W.G.																						
K1 (1/6) K2 (1/6) K3 (1/6) K4 (1/6) K5 (1/6) L5 (1/4) L6 (1/4) M6 (1/3) M7 (1/3) P7 (1/2) P8 (1/2)	RPM	0.000		0.125		0.250		0.375		0.500		0.625		0.750		1.000		1.250		1.500		1.750		
	CFM	BHP	CFM	BHP	CFM	BHP	CFM	BHP	CFM	BHP	CFM	BHP	CFM	BHP	CFM	BHP	CFM	BHP	CFM	BHP	CFM	BHP	CFM	BHP
	650	320	0.01	172	0.01																			
	750	369	0.02	261	0.02																			
	850	418	0.03	327	0.03																			
	950	468	0.04	390	0.04	276	0.04																	
	1050	517	0.05	448	0.05	360	0.05																	
	1150	566	0.06	504	0.07	428	0.07	324	0.06															
	1250	615	0.08	560	0.08	493	0.08	411	0.08															
	1350	665	0.10	614	0.10	555	0.11	486	0.10	396	0.10													
	1450	714	0.13	668	0.13	613	0.13	552	0.13	481	0.13	380	0.13											
	1500	738	0.14	694	0.14	642	0.15	584	0.15	521	0.14	435	0.14											
	1550	759	0.13	720	0.13	670	0.14	616	0.14	545	0.14	475	0.14	362	0.13									
	1600	784	0.14	747	0.15	698	0.15	647	0.15	581	0.15	512	0.15	427	0.15									
	1650	808	0.16	773	0.16	726	0.16	677	0.17	616	0.17	549	0.17	483	0.17									
	1700	833	0.17	799	0.17	754	0.18	707	0.18	650	0.18	586	0.18	522	0.18									
	1750	857	0.19	825	0.19	782	0.20	736	0.20	684	0.20	622	0.20	559	0.20									
	1800	882	0.20	851	0.21	809	0.21	765	0.21	718	0.22	657	0.22	596	0.22	432	0.21							
	1850	906	0.22	877	0.22	836	0.23	793	0.23	748	0.24	692	0.24	633	0.24	496	0.23							
	1900	931	0.22	900	0.23	862	0.23	820	0.24	779	0.24	734	0.24	683	0.24	553	0.24							
	1950	955	0.24	926	0.24	889	0.24	847	0.25	809	0.26	765	0.26	717	0.26	591	0.26							
	2000	980	0.26	951	0.26	916	0.26	875	0.27	837	0.28	796	0.28	750	0.28	638	0.28							
	2050	1004	0.28	977	0.28	943	0.28	903	0.29	866	0.30	826	0.30	783	0.30	680	0.30							
	2100	1029	0.30	1002	0.30	969	0.30	931	0.31	894	0.32	856	0.32	816	0.33	721	0.32							
	2150	1053	0.32	1028	0.33	996	0.33	959	0.33	922	0.34	886	0.34	847	0.35	759	0.35							
	2200	1078	0.34	1053	0.35	1022	0.35	986	0.35	950	0.36	916	0.37	877	0.37	793	0.37							
	2250	1102	0.37	1078	0.37	1048	0.37	1013	0.37	978	0.39	944	0.39	908	0.40	827	0.40	725	0.40					
	2300	1133	0.37	1111	0.37	1080	0.38	1047	0.39	1013	0.39	978	0.40	942	0.40	867	0.41	780	0.41	659	0.40			
	2350	1158	0.39	1136	0.40	1106	0.41	1074	0.41	1041	0.42	1007	0.42	972	0.43	899	0.44	816	0.44	705	0.43			
	2400	1183	0.42	1162	0.42	1132	0.43	1101	0.44	1068	0.44	1036	0.45	1002	0.45	932	0.46	852	0.47	750	0.46			
	2450	1207	0.44	1187	0.45	1158	0.46	1128	0.47	1096	0.47	1064	0.47	1031	0.48	964	0.49	887	0.50	794	0.49			
	2500	1232	0.47	1212	0.48	1184	0.49	1154	0.50	1124	0.50	1093	0.50	1060	0.51	994	0.52	921	0.53	838	0.53	726	0.51	

Performance certified is for installation type A - free inlet, free outlet.  
 Performance ratings (bhp) do not include transmission losses.  
 Performance ratings do not include the effects of accessories.

# VQBL 10

## BELT DRIVE

### PERFORMANCE DATA

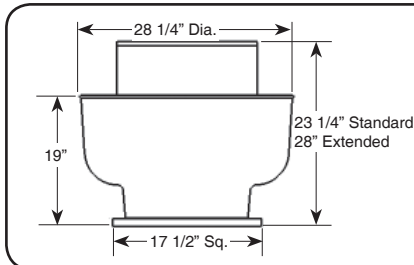

#### DESIGN DATA

Max BHP = .094 x  $\left[\frac{\text{RPM}}{1000}\right]^3$   
 Tip Speed = 3.27 x RPM  
 Max. Motor Frame Size = 145T  
 Unit Weight (less motor) = 45 lbs.  
 Roof Opening = 13" Sq.  
 Curb O. D. = 16" Sq.

RPM Range - Motor HP	RPM	STATIC PRESSURE, INCHES W.G.																													
		0.000	0.125	0.250	0.375	0.500	0.625	0.750	1.000	1.250	1.500	1.750	2.000	2.250	2.500	2.750															
		CFM/BHP	CFM/BHP	CFM/BHP	CFM/BHP	CFM/BHP	CFM/BHP	CFM/BHP	CFM/BHP	CFM/BHP	CFM/BHP	CFM/BHP	CFM/BHP	CFM/BHP	CFM/BHP	CFM/BHP															
K1(1/6)	650	509	0.02	385	0.02																										
	750	587	0.02	486	0.03	332	0.03																								
K2(1/6)	850	665	0.04	577	0.04	461	0.04																								
	950	744	0.05	666	0.05	581	0.06	448	0.06																						
K3(1/6)	1050	822	0.07	752	0.07	678	0.07	575	0.08	455	0.08																				
	1150	900	0.09	837	0.09	770	0.09	696	0.10	586	0.10	427	0.10																		
K4(1/4)	1250	979	0.11	920	0.11	859	0.12	797	0.13	710	0.13	609	0.13	432	0.12																
	1350	1057	0.14	1003	0.14	947	0.15	889	0.15	829	0.16	736	0.16	642	0.17																
L4(1/4)	1450	1135	0.18	1085	0.18	1034	0.18	980	0.19	926	0.20	857	0.20	770	0.20	523	0.20														
	1500	1158	0.17	1112	0.18	1066	0.19	1013	0.20	959	0.21	906	0.22	822	0.21	634	0.21														
L5(1/4)	1550	1196	0.19	1152	0.20	1107	0.21	1057	0.22	1005	0.23	954	0.23	885	0.24	711	0.23	73	0.13												
	1600	1235	0.21	1192	0.22	1149	0.23	1101	0.24	1051	0.25	1001	0.25	947	0.26	778	0.26	481	0.23												
M5(1/3)	1650	1274	0.23	1232	0.24	1190	0.25	1144	0.26	1096	0.27	1047	0.28	999	0.29	844	0.28	630	0.27												
	1700	1312	0.25	1272	0.26	1231	0.27	1188	0.28	1141	0.29	1094	0.30	1046	0.31	909	0.31	750	0.31	97	0.18										
P5(1/2)	1750	1351	0.27	1312	0.29	1272	0.30	1231	0.31	1185	0.31	1139	0.32	1094	0.33	972	0.34	818	0.34	519	0.30										
	1800	1389	0.29	1352	0.31	1313	0.33	1274	0.33	1229	0.34	1185	0.35	1140	0.36	1035	0.37	885	0.37	668	0.35										
P6(1/2)	1850	1428	0.32	1392	0.34	1353	0.35	1316	0.36	1273	0.37	1230	0.38	1187	0.39	1096	0.41	950	0.40	804	0.40	223	0.26								
	1900	1463	0.34	1436	0.35	1400	0.36	1363	0.37	1326	0.38	1284	0.39	1242	0.40	1150	0.42	1027	0.43	877	0.42	647	0.39								
P6(3/4)	1950	1501	0.37	1476	0.38	1440	0.39	1405	0.40	1370	0.41	1329	0.42	1288	0.43	591	0.45	1087	0.46	963	0.47	748	0.44								
	2000	1540	0.40	1516	0.41	1481	0.42	1446	0.43	1412	0.44	1373	0.45	1334	0.46	1249	0.48	1146	0.49	1025	0.50	846	0.48	369	0.36						
R7(3/4)	2050	1578	0.43	1556	0.44	1521	0.45	1488	0.46	1454	0.47	1418	0.48	1379	0.49	1299	0.51	1204	0.53	1087	0.54	942	0.53	730	0.50						
	2100	1617	0.46	1596	0.47	1561	0.48	1529	0.49	1496	0.51	1462	0.52	1424	0.53	1347	0.55	1261	0.56	1147	0.57	1033	0.58	830	0.55	165	0.34				
S7(1)	2150	1655	0.49	1636	0.51	1602	0.52	1570	0.53	1538	0.54	1505	0.55	1468	0.56	1394	0.58	1311	0.60	1207	0.61	1095	0.62	928	0.60	725	0.57				
	2200	1694	0.53	1675	0.54	1642	0.55	1611	0.56	1579	0.58	1548	0.59	1513	0.60	1440	0.62	1361	0.64	1266	0.65	1156	0.66	1024	0.66	826	0.63	29	0.33		
S8(1)	2250	1732	0.57	1715	0.58	1682	0.59	1651	0.60	1621	0.61	1590	0.63	1557	0.64	1486	0.66	1411	0.68	1324	0.70	1217	0.71	1110	0.72	925	0.68	612	0.59		
	2300	1771	0.61	1755	0.62	1722	0.63	1692	0.64	1662	0.65	1632	0.67	1601	0.68	1531	0.70	1460	0.72	1381	0.74	1277	0.75	1172	0.76	1022	0.75	832	0.71		
S8(1)	2350	1809	0.65	1794	0.66	1762	0.67	1733	0.68	1704	0.70	1674	0.71	1644	0.72	1577	0.74	1509	0.77	1431	0.79	1336	0.80	1234	0.81	1117	0.81	932	0.77	494	0.61
	2400	1848	0.69	1833	0.70	1802	0.71	1773	0.73	1745	0.74	1716	0.75	1688	0.77	1622	0.79	1555	0.81	1481	0.83	1395	0.85	1295	0.86	1194	0.87	1030	0.84	848	0.80
S8(1)	2450	1886	0.73	1872	0.74	1842	0.76	1814	0.77	1786	0.78	1758	0.80	1730	0.81	1666	0.84	1601	0.86	1531	0.88	1453	0.90	1355	0.91	1257	0.92	1126	0.91	948	0.87
	2500	1925	0.78	1911	0.79	1882	0.80	1854	0.82	1827	0.83	1799	0.84	1772	0.86	1711	0.88	1647	0.91	1580	0.93	1507	0.95	1414	0.96	1318	0.97	1221	0.98	1047	0.94

Performance certified is for installation type A - free inlet, free outlet.  
 Performance ratings (bhp) do not include transmission losses.  
 Performance ratings do not include the effects of accessories.

# VQBL 12

## BELT DRIVE

### PERFORMANCE DATA

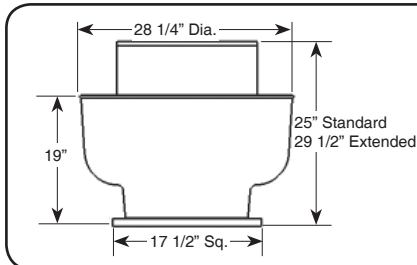

#### DESIGN DATA

Max BHP = .094 x  $\left[\frac{\text{RPM}}{1000}\right]^3$   
 Tip Speed = 3.27 x RPM  
 Max. Motor Frame Size = 145T  
 Unit Weight (less motor) = 45 lbs.  
 Roof Opening = 13" Sq.  
 Curb O. D. = 16" Sq.

RPM Range - Motor HP		STATIC PRESSURE, INCHES W.G.																																								
K1 (1/6)	K2 (1/6)	RPM	0.000		0.125		0.250		0.375		0.500		0.625		0.750		1.000		1.250		1.500		1.750		2.000		2.125		2.250		2.375		2.500		2.625							
			CFM	BHP	CFM	BHP	CFM	BHP	CFM	BHP	CFM	BHP	CFM	BHP	CFM	BHP	CFM	BHP	CFM	BHP	CFM	BHP	CFM	BHP	CFM	BHP	CFM	BHP	CFM	BHP	CFM	BHP	CFM	BHP	CFM	BHP						
K3 (1/6)	L4 (1/4)	650	602	0.02	469	0.03																																				
		750	695	0.03	584	0.04	409	0.04																																		
M4 (1/3)	M6 (1/3)	850	788	0.05	694	0.05	573	0.06																																		
		950	880	0.07	800	0.07	700	0.08	554	0.08																																
P5 (1/2)	R6 (3/4)	1050	973	0.09	903	0.10	814	0.10	716	0.11	552	0.10																														
		1150	1066	0.12	1004	0.13	925	0.13	841	0.14	727	0.14																														
S7 (1)	T8 (1-1/2)	1250	1158	0.16	1103	0.16	1034	0.17	957	0.17	879	0.18	755	0.18																												
		1350	1251	0.20	1201	0.20	1139	0.21	1069	0.22	997	0.22	915	0.23	795	0.22																										
S7 (1)	T8 (1-1/2)	1450	1344	0.25	1299	0.25	1241	0.26	1179	0.26	1112	0.27	1045	0.28	957	0.28																										
		1500	1390	0.27	1347	0.28	1292	0.28	1233	0.29	1168	0.30	1104	0.31	1036	0.31	819	0.30																								
S7 (1)	T8 (1-1/2)	1550	1437	0.28	1388	0.29	1335	0.30	1280	0.31	1224	0.31	1163	0.32	1091	0.32	899	0.32																								
		1600	1483	0.31	1437	0.32	1385	0.32	1332	0.34	1279	0.34	1220	0.35	1154	0.36	992	0.36																								
S7 (1)	T8 (1-1/2)	1650	1529	0.34	1485	0.35	1435	0.35	1384	0.37	1332	0.37	1276	0.38	1216	0.39	1080	0.40																								
		1700	1576	0.37	1533	0.38	1484	0.39	1436	0.40	1384	0.41	1332	0.41	1276	0.42	1145	0.43																								
S7 (1)	T8 (1-1/2)	1750	1622	0.41	1581	0.42	1533	0.42	1486	0.43	1436	0.44	1388	0.45	1333	0.46	1209	0.47	1038	0.47																						
		1800	1668	0.44	1628	0.45	1582	0.45	1537	0.47	1489	0.48	1442	0.49	1390	0.50	1273	0.51	1129	0.51																						
S7 (1)	T8 (1-1/2)	1850	1715	0.48	1676	0.49	1631	0.49	1587	0.50	1541	0.52	1494	0.53	1446	0.53	1336	0.55	1214	0.56																						
		1900	1761	0.52	1724	0.53	1680	0.53	1637	0.54	1593	0.56	1547	0.57	1501	0.57	1398	0.59	1279	0.60	1106	0.60																				
S7 (1)	T8 (1-1/2)	1950	1810	0.54	1772	0.56	1732	0.57	1691	0.58	1647	0.59	1603	0.60	1559	0.61	1465	0.63	1355	0.63	1200	0.63																				
		2000	1856	0.59	1820	0.60	1780	0.61	1740	0.63	1699	0.64	1655	0.65	1612	0.66	1522	0.67	1418	0.68	1295	0.68	1082	0.66																		
S7 (1)	T8 (1-1/2)	2050	1903	0.63	1868	0.64	1828	0.66	1790	0.67	1750	0.69	1707	0.70	1665	0.70	1578	0.72	1480	0.73	1375	0.74	1188	0.72																		
		2100	1949	0.68	1915	0.69	1877	0.71	1839	0.72	1801	0.74	1759	0.75	1718	0.75	1634	0.77	1541	0.78	1439	0.79	1284	0.78																		
S7 (1)	T8 (1-1/2)	2150	1996	0.73	1963	0.74	1925	0.76	1888	0.77	1851	0.79	1811	0.80	1771	0.81	1690	0.83	1602	0.84	1502	0.85	1379	0.85	1188	0.83																
		2200	2042	0.78	2010	0.79	1973	0.81	1937	0.82	1901	0.84	1862	0.85	1823	0.86	1744	0.88	1661	0.90	1565	0.91	1467	0.91	1286	0.90	1193	0.88														
S7 (1)	T8 (1-1/2)	2250	2088	0.83	2057	0.85	2021	0.86	1986	0.88	1951	0.90	1913	0.91	1875	0.92	1798	0.94	1717	0.96	1626	0.97	1531	0.98	1383	0.97	1291	0.95	1200	0.94												
		2300	2135	0.89	2105	0.91	2069	0.92	2035	0.94	2000	0.95	1964	0.97	1927	0.98	1851	1.00	1774	1.02	1688	1.03	1594	1.04	1477	1.04	1413	1.04	1361	1.04	1249	1.02										
S7 (1)	T8 (1-1/2)	2350	2178	0.94	2147	0.95	2114	0.97	2080	0.99	2044	1.00	2010	1.02	1976	1.03	1904	1.05	1830	1.08	1740	1.09	1637	1.10	1534	1.10	1483	1.10	1431	1.11	1369	1.10	1258	1.08								
		2400	2224	1.00	2195	1.01	2161	1.03	2129	1.05	2094	1.06	2060	1.08	2027	1.10	1957	1.12	1885	1.14	1803	1.16	1702	1.17	1601	1.17	1551	1.17	1501	1.18	1450	1.18	1376	1.17	1226	1.14						
S7 (1)	T8 (1-1/2)	2450	2270	1.07	2242	1.08	2209	1.10	2177	1.12	2143	1.13	2110	1.14	2078	1.16	2009	1.19	1939	1.21	1866	1.24	1767	1.24	1668	1.24	1619	1.25	1569	1.25	1520	1.25	1470	1.25	1348	1.23						
		2500	2316	1.13	2289	1.15	2256	1.16	2226	1.19	2192	1.20	2159	1.21	2128	1.23	2061	1.26	1993	1.28	1923	1.31	1831	1.32	1734	1.32	1686	1.32	1637	1.33	1589	1.33	1540	1.33	1467	1.33						

Performance certified is for installation type A - free inlet, free outlet.  
 Performance ratings (bhp) do not include transmission losses.  
 Performance ratings do not include the effects of accessories.

Cent. Restaurant Roof



# VQBL 15

## BELT DRIVE

### PERFORMANCE DATA

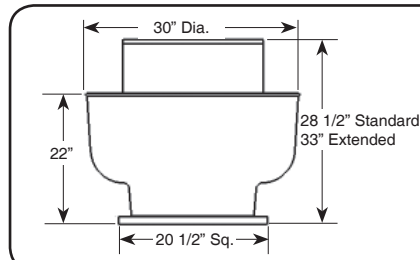

#### DESIGN DATA

Max BHP = .285 x  $\left[\frac{\text{RPM}}{1000}\right]^3$   
 Tip Speed = 4.06 x RPM  
 Max. Motor Frame Size = 182T  
 Unit Weight (less motor) = 65 lbs.  
 Roof Opening = 16" Sq.  
 Curb O. D. = 19" Sq.

RPM Range - Motor HP	RPM	STATIC PRESSURE, INCHES W.G.																													
		0.000		0.125		0.250		0.375		0.500		0.750		1.000		1.250		1.500		1.750		2.000		2.250		2.500		2.750		3.000	
		CFM	BHP	CFM	BHP	CFM	BHP	CFM	BHP	CFM	BHP	CFM	BHP	CFM	BHP	CFM	BHP	CFM	BHP	CFM	BHP	CFM	BHP	CFM	BHP	CFM	BHP	CFM	BHP	CFM	BHP
K1 (1/6)	550	1138	0.04	902	0.05																										
K2 (1/6)	600	1241	0.06	1030	0.07	679	0.06																								
L2 (1/4)	650	1345	0.07	1155	0.08	857	0.08																								
M3 (1/3)	700	1448	0.09	1276	0.10	1025	0.10	437	0.08																						
P3 (1/2)	750	1552	0.11	1391	0.12	1188	0.13	887	0.12																						
P4 (1/2)	800	1655	0.14	1505	0.15	1334	0.16	1063	0.15																						
P4 (3/4)	850	1759	0.16	1617	0.17	1461	0.19	1232	0.18	966	0.17																				
S4 (1)	900	1862	0.20	1729	0.20	1586	0.22	1395	0.22	1144	0.21																				
S5 (1)	950	1965	0.23	1839	0.24	1709	0.26	1554	0.26	1316	0.25																				
T5 (1.5)	1000	2069	0.27	1949	0.27	1828	0.29	1685	0.30	1483	0.30	779	0.25																		
V5 (2)	1050	2172	0.31	2059	0.31	1943	0.34	1812	0.35	1645	0.35	1216	0.33																		
V6 (3)	1100	2267	0.33	2185	0.34	2076	0.36	1951	0.37	1825	0.38	1505	0.39																		
	1150	2370	0.38	2293	0.39	2193	0.41	2073	0.42	1953	0.43	1664	0.44	1120	0.40																
	1200	2473	0.43	2401	0.44	2306	0.47	2194	0.48	2079	0.49	1821	0.50	1383	0.48																
	1250	2576	0.48	2509	0.50	2417	0.52	2313	0.54	2203	0.55	1973	0.56	1638	0.56																
	1300	2679	0.54	2617	0.56	2528	0.58	2432	0.60	2326	0.61	2113	0.63	1833	0.64	1328	0.58														
	1400	2885	0.68	2831	0.69	2749	0.72	2666	0.75	2568	0.76	2370	0.78	2146	0.79	1844	0.79	1326	0.72												
	1450	2988	0.75	2937	0.77	2859	0.80	2780	0.83	2687	0.84	2497	0.86	2299	0.88	2039	0.89	1592	0.83												
	1500	3131	0.83	3058	0.84	2981	0.85	2903	0.87	2823	0.90	2652	0.94	2449	0.96	2225	0.98	1894	0.95	852	0.63										
	1550	3236	0.92	3165	0.93	3090	0.94	3015	0.96	2938	0.98	2774	1.03	2590	1.05	2372	1.07	2102	1.07	1532	0.93										
	1600	3340	1.01	3271	1.02	3203	1.03	3127	1.05	3052	1.08	2895	1.12	2723	1.15	2518	1.17	2305	1.19	1961	1.15										
	1650	3444	1.11	3378	1.12	3307	1.13	3238	1.14	3166	1.17	3015	1.22	2853	1.26	2662	1.28	2457	1.30	2171	1.28	1544	1.08								
	1700	3549	1.21	3484	1.22	3416	1.23	3349	1.25	3279	1.28	3135	1.33	2981	1.37	2803	1.39	2605	1.41	2376	1.42	2052	1.37								
	1725	3601	1.27	3537	1.27	3470	1.29	3404	1.30	3336	1.33	3194	1.38	3045	1.43	2874	1.45	2678	1.47	2477	1.49	2158	1.44	1298	1.10						
	1750	3653	1.32	3590	1.33	3528	1.34	3459	1.36	3392	1.38	3253	1.44	3106	1.48	2943	1.51	2751	1.53	2558	1.56	2263	1.52	1636	1.29						
	1800	3758	1.44	3697	1.45	3635	1.46	3569	1.47	3504	1.50	3371	1.56	3228	1.60	3074	1.64	2894	1.66	2707	1.68	2469	1.67	2163	1.62	1117	1.14				
	1850	3851	1.54	3796	1.56	3739	1.58	3680	1.60	3621	1.63	3494	1.68	3356	1.74	3207	1.78	3045	1.81	2863	1.82	2637	1.82	2047	1.83	1457	1.84				
	1900	3955	1.67	3902	1.69	3846	1.71	3789	1.73	3731	1.76	3609	1.82	3478	1.87	3334	1.91	3185	1.96	3009	1.97	2832	1.97	2386	1.98	1812	1.99	1237	1.99		
	1950	4059	1.80	4007	1.83	3953	1.85	3898	1.86	3841	1.90	3723	1.95	3599	2.02	3460	2.05	3316	2.11	3152	2.12	2980	2.13	2717	2.13	2158	2.14	1598	2.15		
	2000	4163	1.95	4113	1.97	4060	1.99	4006	2.01	3951	2.04	3837	2.10	3718	2.16	3584	2.21	3445	2.26	3294	2.29	3126	2.30	2958	2.30	2496	2.31	1951	2.31	1405	2.32

Performance certified is for installation type A - free inlet, free outlet.  
 Performance ratings (bhp) do not include transmission losses.  
 Performance ratings do not include the effects of accessories.

# VQBL 18

## BELT DRIVE

### PERFORMANCE DATA

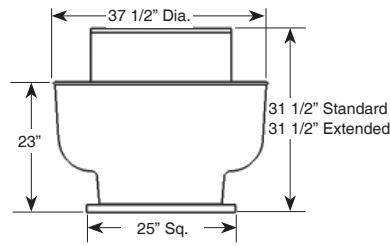

#### DESIGN DATA

Max BHP = .659 x  $\left[ \frac{\text{RPM}}{1000} \right]^3$

Tip Speed = 4.94 x RPM  
 Max. Motor Frame Size = 184T  
 Unit Weight (less motor) = 85 lbs.  
 Roof Opening = 20-1/2" Sq.  
 Curb O. D. = 23-1/2" Sq.

RPM Range - Motor HP	RPM	STATIC PRESSURE, INCHES W.G.															
		0.000		0.250		0.500		0.750		1.000		1.250		1.500		1.750	
		CFM	BHP	CFM	BHP	CFM	BHP	CFM	BHP	CFM	BHP	CFM	BHP	CFM	BHP	CFM	BHP
K1 (1/6)	550	2155	0.11														
	575	2253	0.12														
	600	2351	0.14														
L1 (1/4)	650	2547	0.18														
	675	2645	0.20														
L2 (1/4)	700	2743	0.22														
	725	2745	0.20	2186	0.25	1394	0.25										
M2 (1/3)	750	2840	0.22	2296	0.27	1581	0.28										
	775	2934	0.24	2405	0.29	1763	0.31										
P2 (1/2)	800	3029	0.27	2513	0.32	1942	0.35										
	825	3123	0.29	2620	0.35	2116	0.39										
R2 (3/4)	850	3218	0.32	2726	0.38	2288	0.43	1412	0.39								
	875	3313	0.35	2831	0.41	2408	0.46	1609	0.43								
R3 (3/4)	900	3407	0.38	2936	0.44	2524	0.50	1799	0.48								
	925	3502	0.41	3040	0.47	2639	0.53	1984	0.53								
S3 (1)	950	3597	0.45	3144	0.51	2753	0.57	2166	0.58								
	975	3691	0.48	3247	0.55	2866	0.61	2344	0.63	1502	0.56						
T4 (1-1/2)	1000	3751	0.42	3371	0.50	2971	0.56	2538	0.60	1539	0.48						
	1025	3844	0.45	3474	0.54	3087	0.59	2676	0.64	1845	0.56						
	1050	3938	0.49	3577	0.57	3201	0.63	2802	0.69	2145	0.65						
	1075	4032	0.52	3679	0.61	3315	0.67	2926	0.73	2437	0.75	1177	0.51				
	1100	4126	0.56	3781	0.65	3428	0.71	3048	0.77	2594	0.80	1495	0.60				
	1125	4219	0.60	3879	0.70	3540	0.76	3168	0.82	2749	0.85	1806	0.70				
	1150	4313	0.64	3976	0.74	3649	0.80	3288	0.87	2903	0.91	2112	0.81				
	1175	4407	0.68	4074	0.79	3757	0.85	3406	0.92	3046	0.97	2411	0.92	1245	0.65		
	1200	4501	0.73	4171	0.83	3865	0.90	3523	0.97	3173	1.03	2706	1.03	1575	0.77		
	1225	4595	0.77	4268	0.88	3972	0.95	3640	1.02	3298	1.09	2870	1.10	1887	0.89		
	1250	4723	0.82	4367	0.92	4063	1.01	3772	1.07	3412	1.14	2997	1.16	2404	1.13		
	1275	4817	0.87	4467	0.98	4166	1.07	3885	1.13	3543	1.20	3149	1.24	2639	1.22		
	1300	4912	0.92	4566	1.03	4268	1.13	3997	1.19	3673	1.26	3290	1.31	2838	1.31		
	1325	5006	0.98	4662	1.09	4371	1.19	4109	1.25	3801	1.33	3427	1.38	3003	1.38	2310	1.29
	1350	5101	1.04	4756	1.15	4474	1.25	4217	1.31	3928	1.40	3562	1.45	3165	1.46	2595	1.42
	1375	5195	1.09	4850	1.21	4578	1.32	4324	1.38	4043	1.47	3695	1.52	3318	1.55	2830	1.53

Performance certified is for installation type A - free inlet, free outlet.  
 Performance ratings (bhp) do not include transmission losses.  
 Performance ratings do not include the effects of accessories.

Cent. Restaurant Roof

**VQBL 06**  
AIR PERFORMANCE

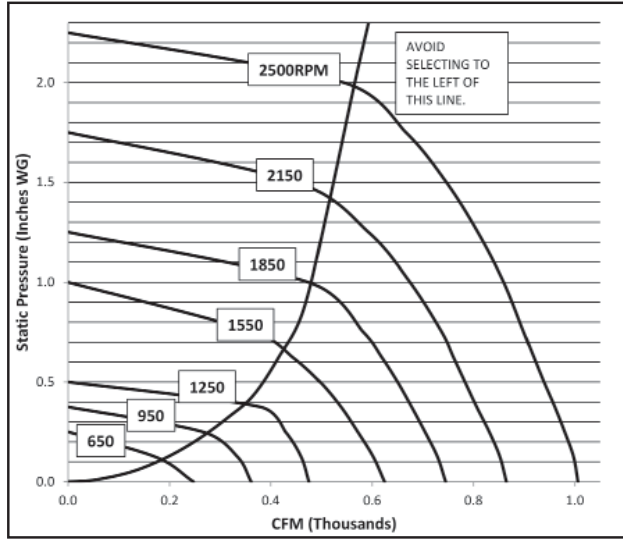

Performance certified is for installation type A - free inlet, free outlet.  
Performance ratings (bhp) do not include transmission losses.  
Performance ratings do not include the effects of accessories.

**VQBL 10**  
AIR PERFORMANCE

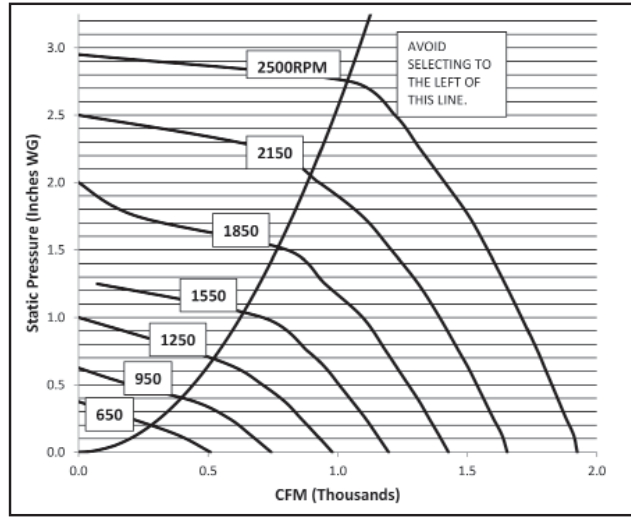

Performance certified is for installation type A - free inlet, free outlet.  
Performance ratings (bhp) do not include transmission losses.  
Performance ratings do not include the effects of accessories.

**VQBL 08**  
AIR PERFORMANCE

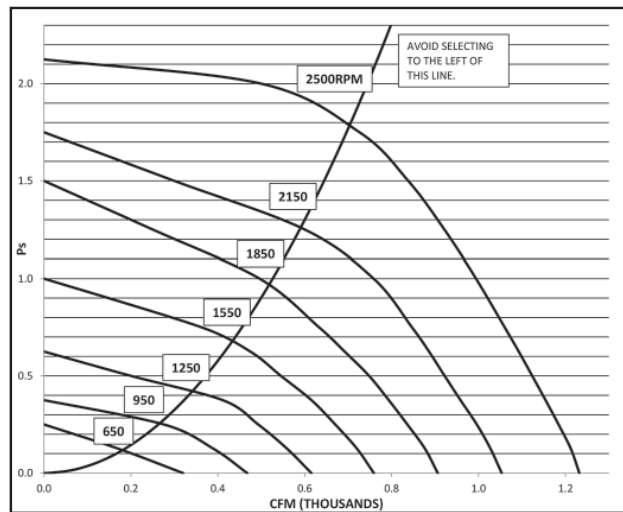

Performance certified is for installation type A - free inlet, free outlet.  
Performance ratings (bhp) do not include transmission losses.  
Performance ratings do not include the effects of accessories.

**VQBL 12**  
AIR PERFORMANCE

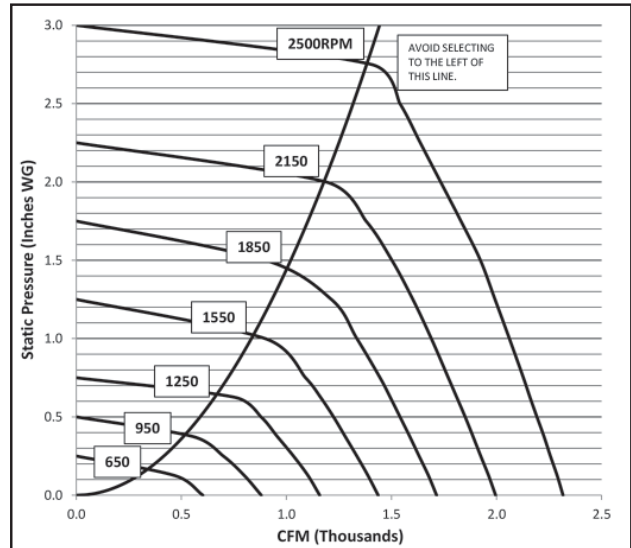

Performance certified is for installation type A - free inlet, free outlet.  
Performance ratings (bhp) do not include transmission losses.  
Performance ratings do not include the effects of accessories.

**VQBL 15**  
AIR PERFORMANCE

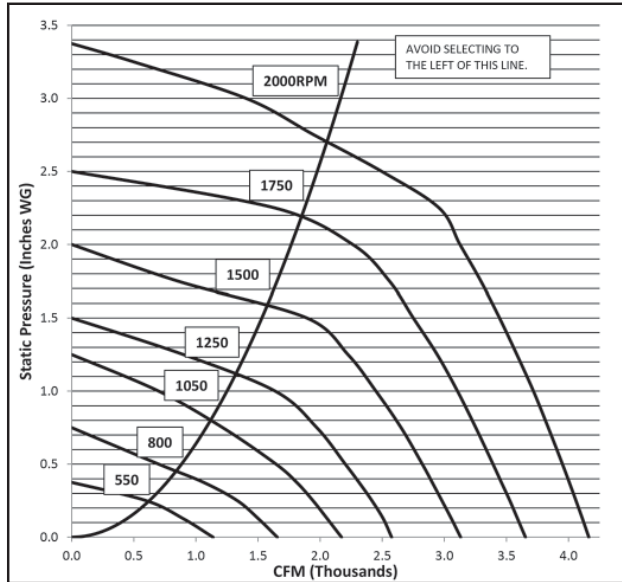

Performance certified is for installation type A - free inlet, free outlet.  
Performance ratings (bhp) do not include transmission losses.  
Performance ratings do not include the effects of accessories.

**VQBL 18**  
AIR PERFORMANCE

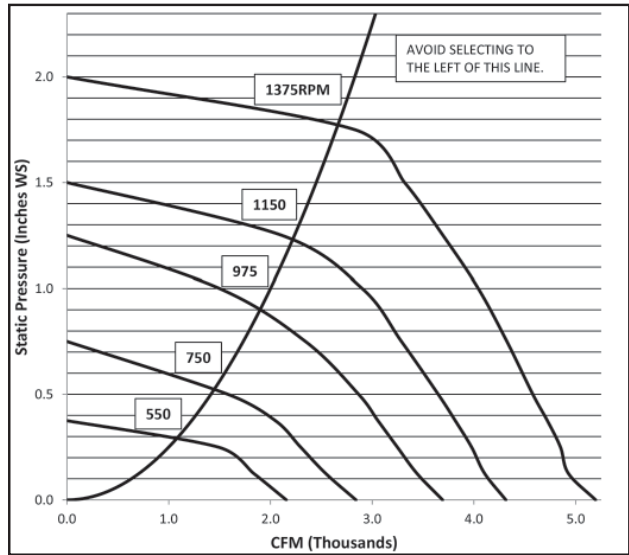

Performance certified is for installation type A - free inlet, free outlet.  
Performance ratings (bhp) do not include transmission losses.  
Performance ratings do not include the effects of accessories.

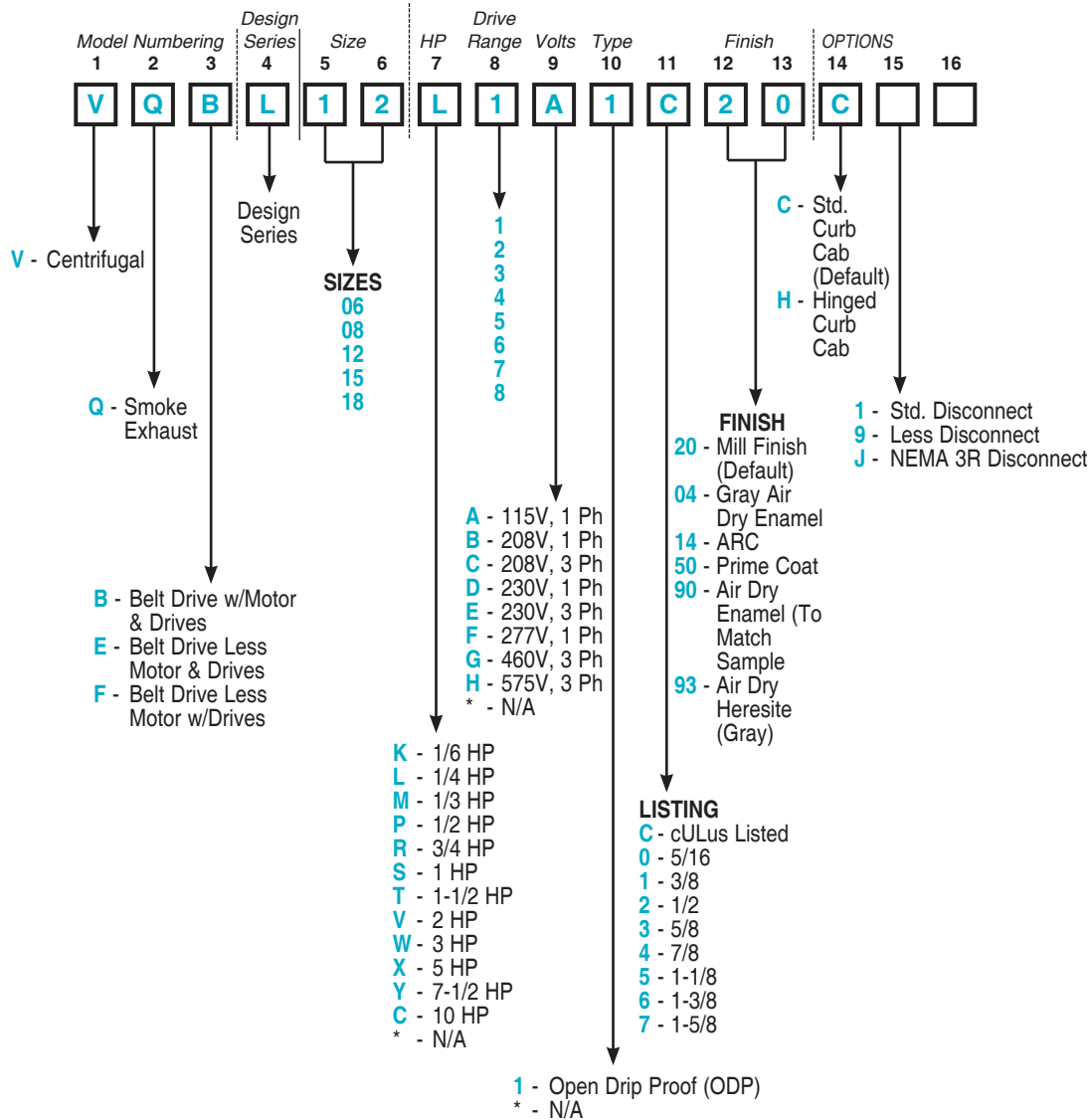

▼ Curbs

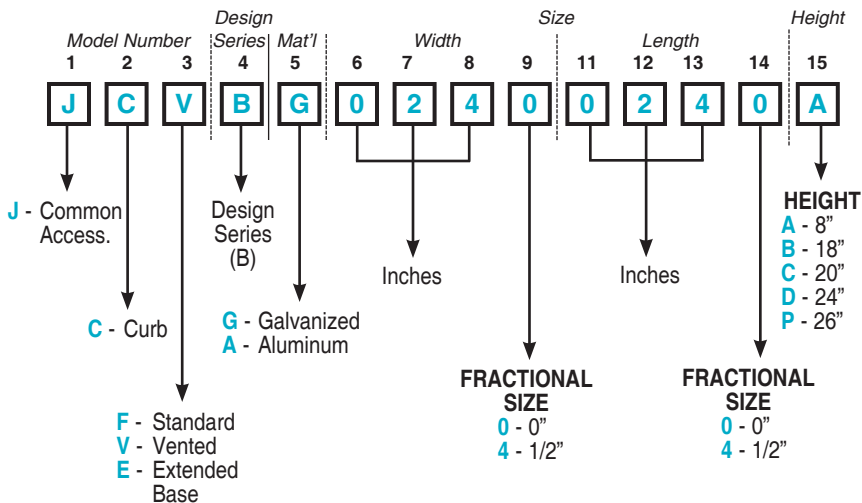

▼ Electrical

